



US 20020139805A1

(19) **United States**

(12) **Patent Application Publication**

**Chasteen et al.**

(10) **Pub. No.: US 2002/0139805 A1**

(43) **Pub. Date: Oct. 3, 2002**

(54) **BEVERAGE CAN END WITH REDUCED COUNTERSINK**

**Related U.S. Application Data**

(76) Inventors: **Howard C. Chasteen**, Golden, CO (US); **Robert M. Rayburn**, Broomfield, CO (US); **Dana H. Scott**, Thornton, CO (US)

(60) Provisional application No. 60/262,829, filed on Jan. 19, 2001.

**Publication Classification**

Correspondence Address:  
**SHERIDAN ROSS PC**  
**1560 BROADWAY**  
**SUITE 1200**  
**DENVER, CO 80202**

(51) **Int. Cl.<sup>7</sup>** ..... **B65D 6/28; B65D 8/04; B65D 8/06**

(52) **U.S. Cl.** ..... **220/623**

(57) **ABSTRACT**

The present invention describes an improved beverage can end which utilizes less material and has an improved internal buckle strength based on the geometric configuration of the chuck wall, inner panel wall, central panel and reduced depth between the countersink and crown of a circular end wall.

(21) Appl. No.: **10/053,749**

(22) Filed: **Jan. 18, 2002**

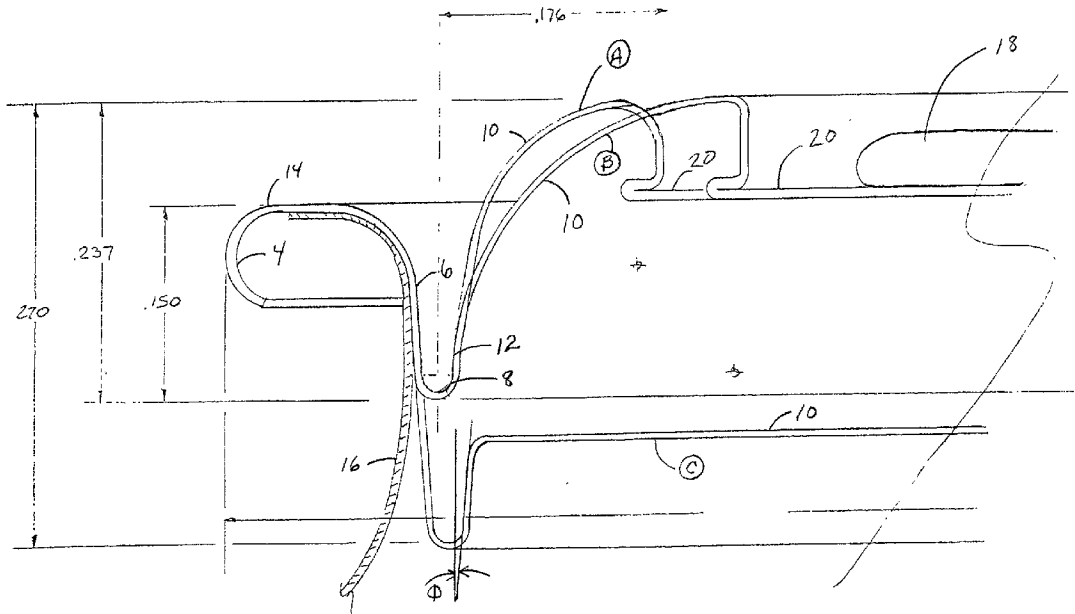

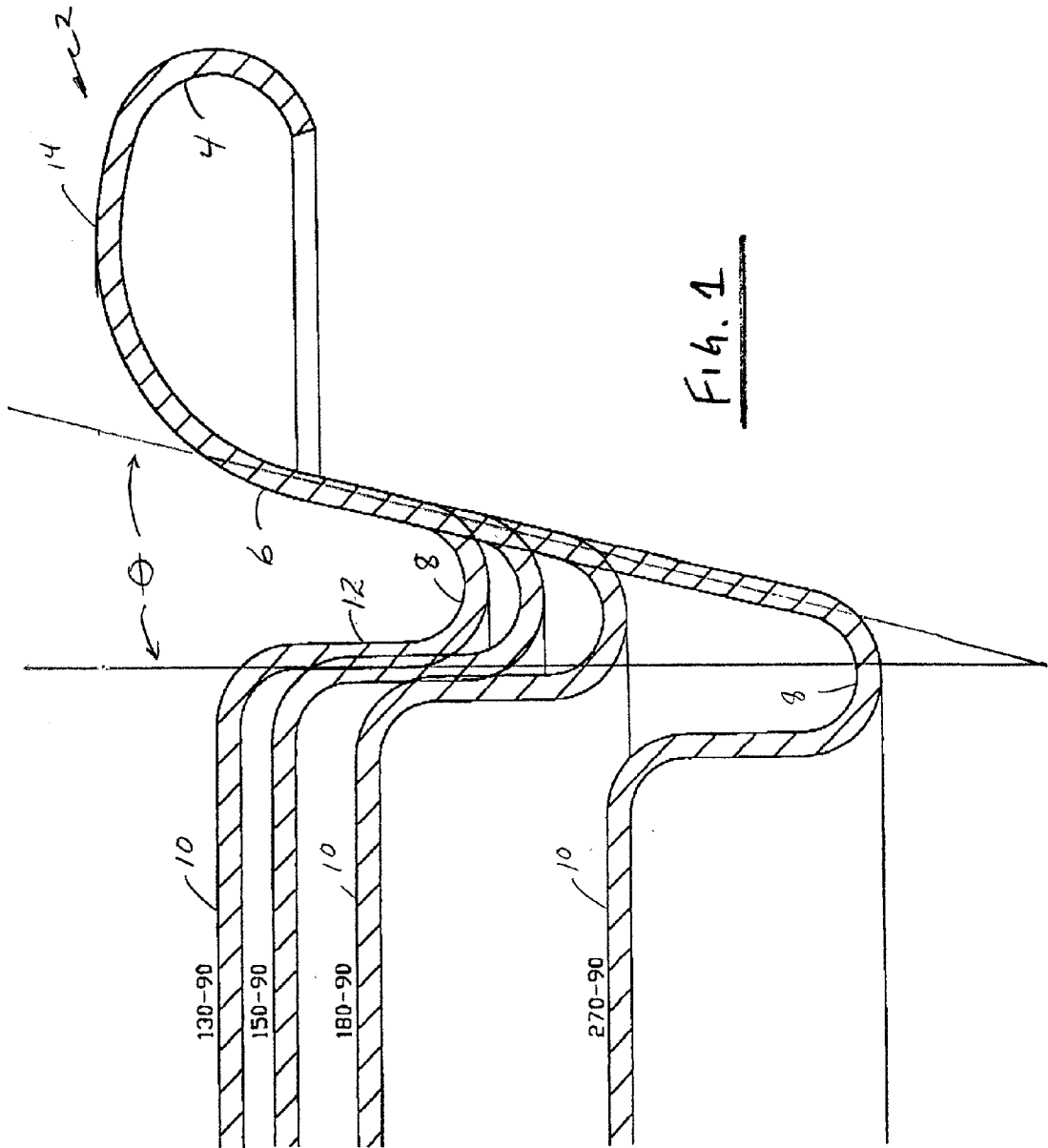
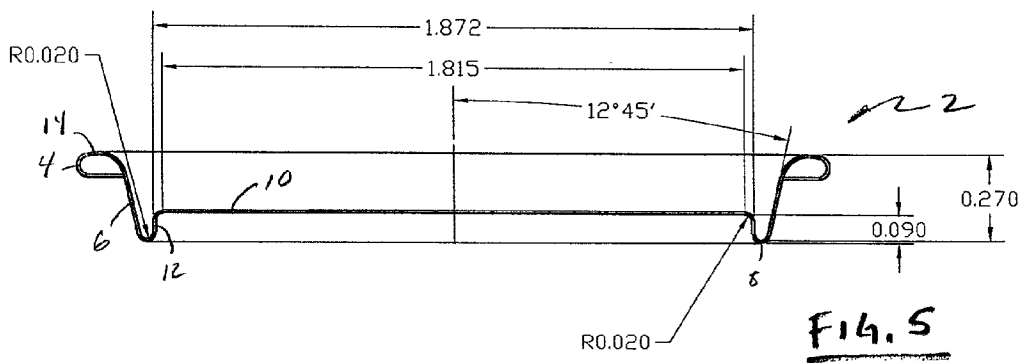
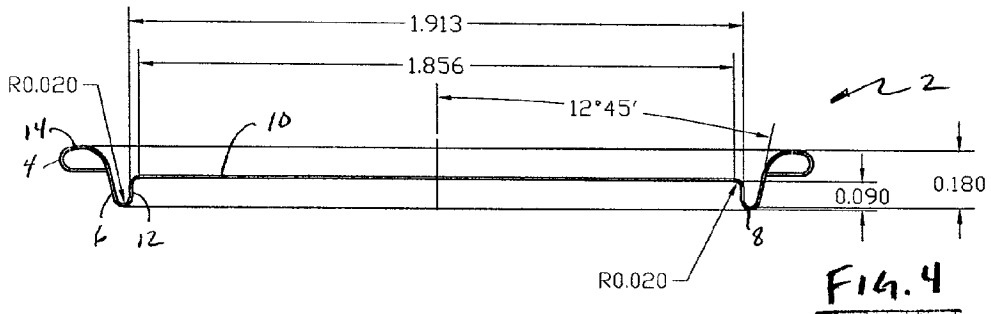
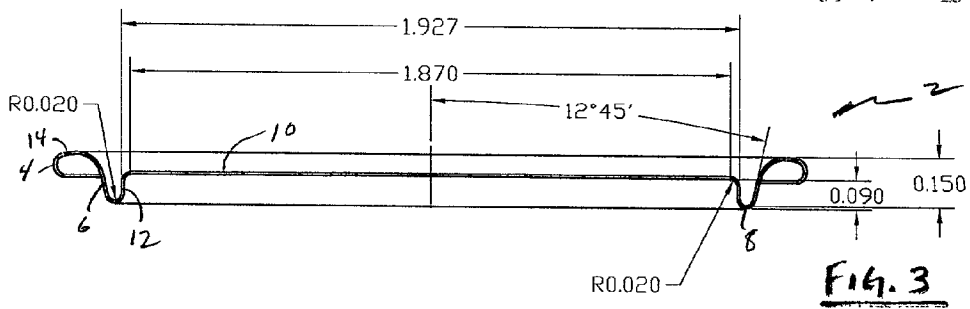
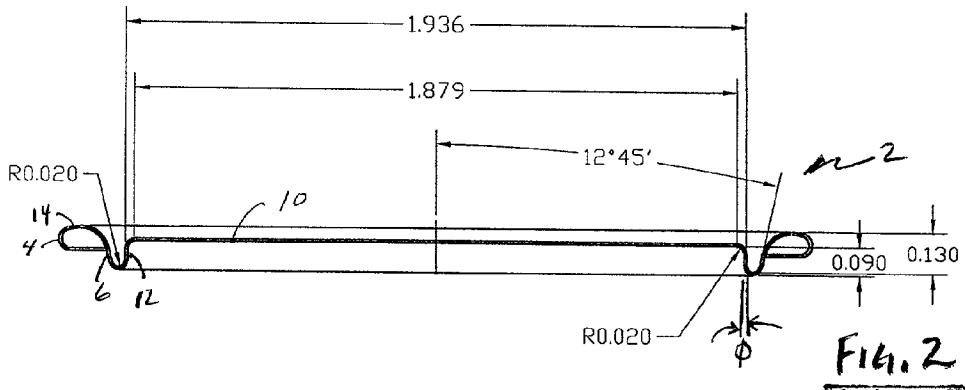

Fig. 1



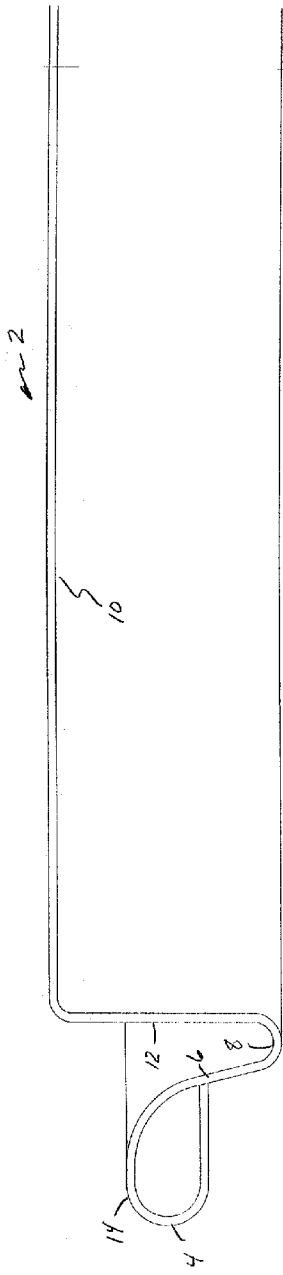

FIG. 6

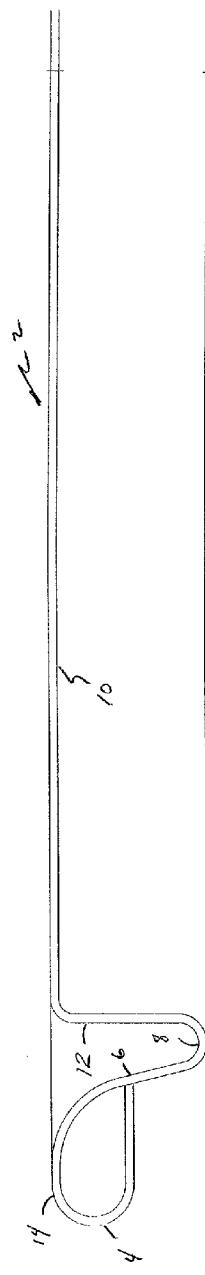

FIG. 6A

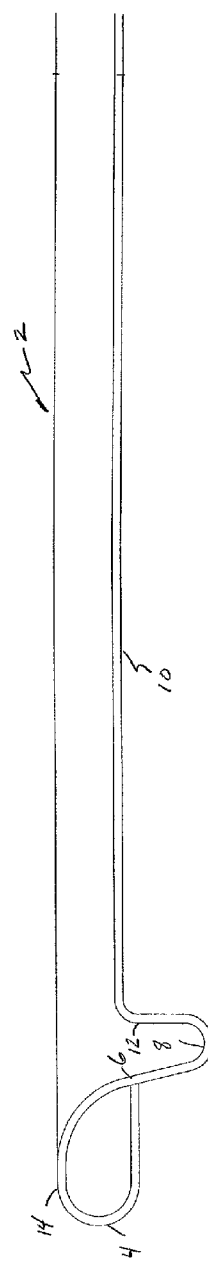

FIG. 6B

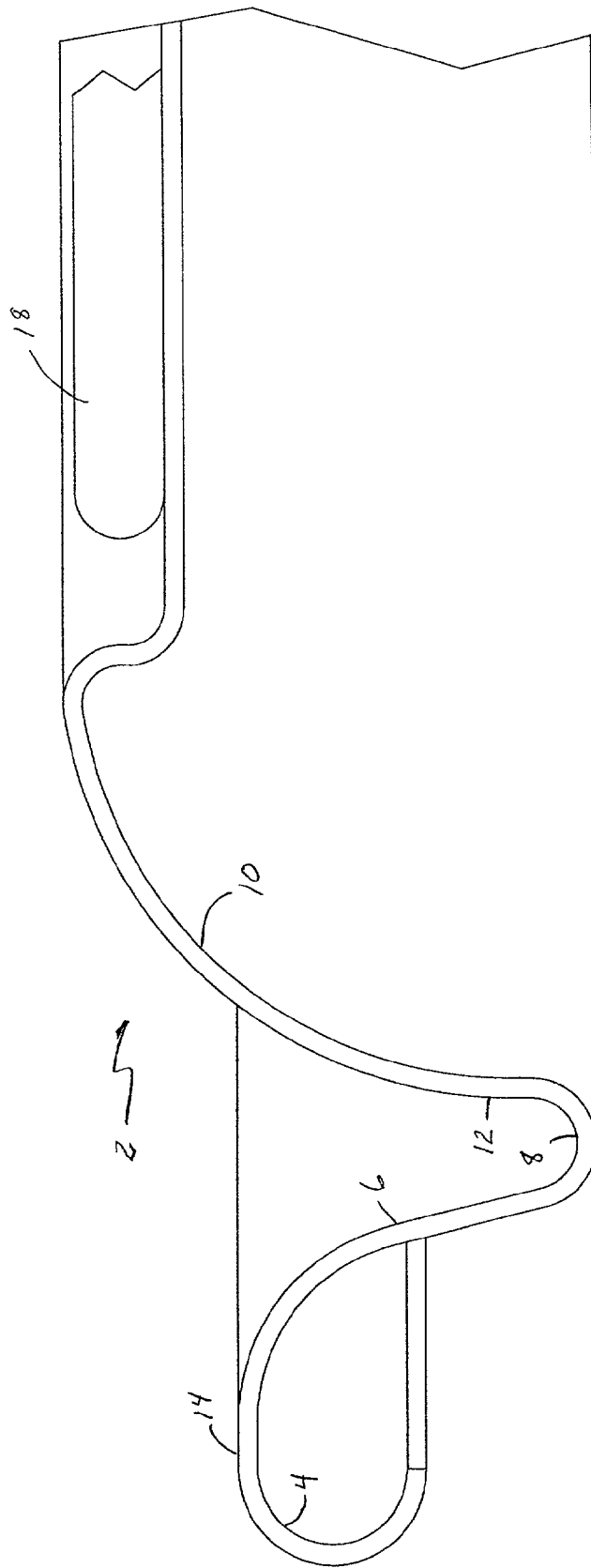

Fig. 7



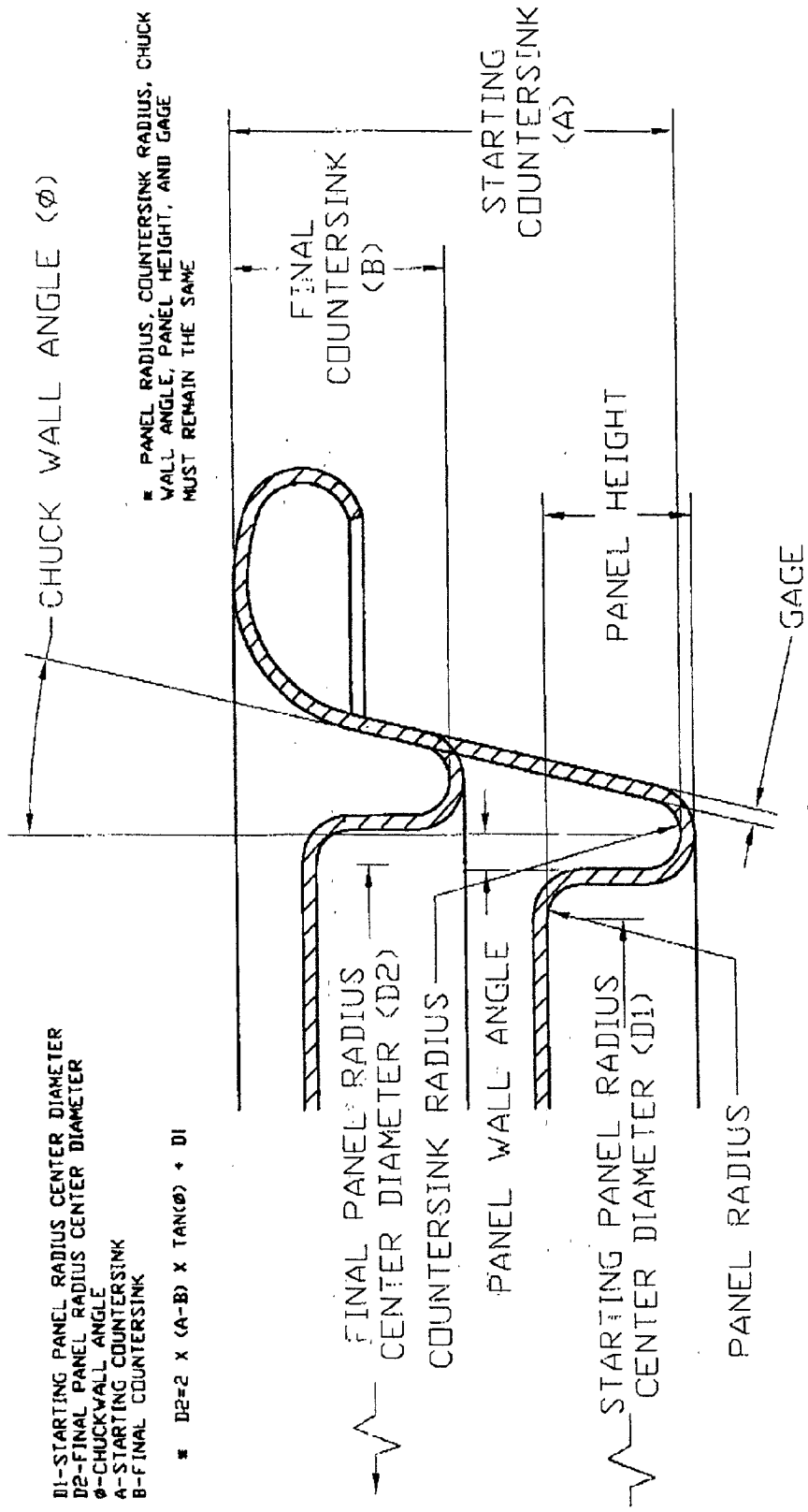

Fig. 9

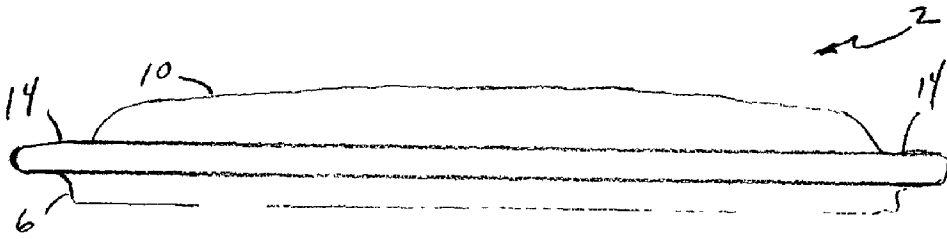

FIG. 10

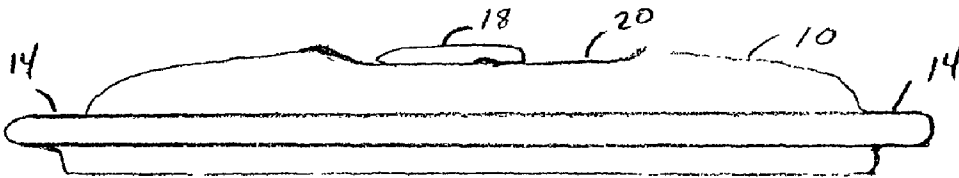

FIG. 11

## BEVERAGE CAN END WITH REDUCED COUNTERSINK

[0001] This application claims priority of U.S. provisional patent application Serial No. 60/262,829 having a filing date of Jan. 19, 2001, and is incorporated herein in its entirety by reference.

### FIELD OF THE INVENTION

[0002] The present invention generally relates to beverage can ends, and more specifically metallic beverage can ends used for interconnection to a beverage can body.

### BACKGROUND OF THE INVENTION

[0003] Beverage cans and more specifically metallic beverage cans are typically manufactured by interconnecting a beverage can end on a beverage container body. In some applications, two ends may be interconnected on a top side and a bottom side of a can body. More frequently, however, a beverage can end is interconnected on a top end of a beverage can body which is drawn and pressed from a flat sheet of blank material such as aluminum. Due to the potentially high internal pressures generated by carbonated beverages, both the beverage can body and the beverage can end are typically subjected to internal pressures which at times can exceed 100 psi.

[0004] Thus, the beverage can ends must be durable to withstand high internal pressures, yet manufactured with extremely thin materials such as aluminum to decrease the overall cost of the manufacturing process and weight of the finished product. Accordingly, there exists a significant need for a durable beverage can end which can withstand the high internal pressures created by carbonated beverages, and the external forces applied during shipping, yet which are made from durable, lightweight and extremely thin metallic materials. It is a further problem to provide a beverage can end which is stackable, and thus can be shipped in bulk. There is a need for a beverage can end which further provides additional head space when double-seamed to a beverage can body, and thus allows for a reduction of materials and associated costs with respect to the beverage can body. Finally, there is a need for a beverage can end which does not accumulate dirt, dust and beverage product in the "mote" created by the countersink.

[0005] The following application describes an improved beverage can end which is adapted for interconnection to a beverage can body and which in one embodiment has a countersink with a reduced depth, as measured from the crown of the circular end wall, and a central panel area which significantly saves material costs yet can withstand significant internal pressures. In other embodiments, an improved beverage can end is provided which has a central panel positioned above the crown of the circular end wall, and an opening tab which is positioned below the height of the central panel.

### SUMMARY OF THE INVENTION

[0006] Thus, in one aspect of the present invention, a beverage can end is provided which can withstand significant internal pressures exceeding 100 psi and yet saves between 5% and 12% of the material costs associated with typical beverage can end manufacturing. This is accom-

plished primarily by reducing the overall depth of the countersink from the height of the crown, the crown being defined herein as the uppermost edge of the circular end wall or the top edge of the double seam after the beverage can end is interconnected to the beverage can body. Preferably the distance from the crown to the lowermost portion of the countersink ranges between about 0.110 inches and 0.270 inches, while the distance from the lowermost portion of the countersink to the maximum height of the central panel is typically between about 0.030 and 0.130 inches.

[0007] In another aspect of the present invention, a beverage can end is provided which is manufactured with conventional manufacturing equipment and thus eliminates the need for expensive new punches and presses required to make the beverage can end. Thus, existing and well known manufacturing equipment and processes can be implemented to quickly and effectively initiate the production of an improved beverage can end in an existing manufacturing facility.

[0008] Another aspect of the present invention to provide a beverage can end is provided which is stackable for shipping purposes, and which has an opening tab which is not an obstruction for stacking purposes and yet readily accessible for a user's fingers. Thus, in another embodiment of the present invention the opening tab is positioned in a recessed portion below the central panel. In one preferred embodiment of the present invention, a beverage can end is provided which has a central panel elevated above the crown of the double-seamed beverage can end, and an opening tab positioned below an uppermost portion of the central panel. This configuration has been found to reduce material costs since the headspace in the can is increased, thus reducing the material and associated costs in the beverage can body. Further, by raising the central panel above the height of the crown, increased strength has been realized as a result of the improved "pressure vessel" geometry of the can end.

[0009] It is another aspect of the present invention to provide a beverage can end which saves material costs by utilizing improved geometry and reducing the size of the blank, as opposed to utilizing thinner materials which are susceptible to failure. Thus, the integrity and strength of the beverage can end is not compromised, while material costs are significantly reduced as a result of the blank reduction.

[0010] Thus, in one aspect of the present invention, a metallic beverage can end is provided which comprises:

[0011] a circular end wall adapted for interconnection to a beverage can body, said circular end wall having a crown on an uppermost edge;

[0012] a chuck wall integrally interconnected to said circular end wall and extending downwardly therefrom at a chuck wall angle  $\theta$  of between about 0 and 15 degrees;

[0013] a countersink integrally interconnected to said chuck wall and extending downwardly therefrom;

[0014] a central panel integrally interconnected to said countersink and extending upwardly therefrom to an elevation at least about the elevation of said crown; and

[0015] an opening means positioned on said central panel which is positioned at an elevation no greater

than said uppermost edge of said central panel, wherein the beverage can may be selectively opened.

#### BRIEF DESCRIPTION OF THE DRAWINGS

[0016] FIG. 1 is a front elevation view depicting an overlay of four different embodiments of a new beverage can end with a reduced countersink and the central panel shown below the crown;

[0017] FIG. 2 is a front elevation view of one embodiment shown in FIG. 1 and identifying dimensions related thereto;

[0018] FIG. 3 is a front elevation view of one embodiment shown in FIG. 1 and identifying dimensions related thereto;

[0019] FIG. 4 is a front elevation view of one embodiment shown in FIG. 1 and identifying dimensions related thereto;

[0020] FIG. 5 is a front elevation view of a prior art beverage can end;

[0021] FIG. 6 is a front elevation view of one embodiment of the present invention with the central panel positioned above the crown of the circular end wall;

[0022] FIG. 6A is a front elevation view of another embodiment of the present invention with the central panel having an elevation approximately the same as the crown of the circular end wall;

[0023] FIG. 6B is a front elevation view of another embodiment of the present invention with a reduced countersink depth as measured from the crown of the circular end wall;

[0024] FIG. 7 is a front elevation view of one embodiment of the present invention wherein the central panel is raised above the crown and a pull tab is positioned below an uppermost edge of the central panel; and

[0025] FIG. 8 is a front elevation view of two alternative embodiments of the present invention showing the central panel raised above the crown, and pull tab positioned below an uppermost edge of the central panel, with a prior art beverage can end provided for reference purposes;

[0026] FIG. 9 is a front elevation view of one embodiment of the present invention and identifying the parameters used to equate the final dimensions of the central panel;

[0027] FIG. 10 is a front elevation view of one embodiment of the present invention with the central panel elevated above the crown of the circular end wall; and

[0028] FIG. 11 is a front elevation view of the embodiment shown in FIG. 10, but with the pull tab located at an elevation below the upper edge of the central panel.

#### DETAILED DESCRIPTION

[0029] Referring now to the drawings, FIGS. 1-8 generally depict front elevation views of various embodiments of the present invention. More specifically, FIG. 1 is an overlay showing the various geometric configurations of numerous embodiments of the present beverage can end 2 and countersink 8, while FIGS. 2-5 are various embodiments of the can end shown in FIG. 1 with dimensions provided therein for greater detail. FIGS. 6-8 are front elevation views which show alternative embodiments of the present invention with the central panel 10 raised above or equal to the crown 14,

as well as an embodiment with the pull tab 18 positioned below the elevation of the uppermost portion of the central panel 10.

[0030] In general, a beverage can end 2 of the present invention is comprised of a circular end wall 4 or curl which is interconnected to a chuck wall 6 and which extends downwardly at a chuck wall angle  $\theta$  to a countersink 8. The countersink generally represents the lowermost portion of the beverage can end and is integrally interconnected to an inner panel wall 12 which extends upwardly toward the central panel 10 in either a substantially vertical direction or at an inner panel wall angle  $\phi$ . Alternatively the inner panel wall 12 may have an arcuate shape with a distinct radius of curvature. The "curl" or circular end wall 4 has an upper edge generally defined as a crown 14, and which typically represents the highest portion of the beverage can end 2. As recognized in the art, the crown may also be referred to as the "chime" once the beverage can end 2 is double seamed to the beverage can body 16.

[0031] The present invention in one embodiment is distinct from prior art beverage can ends in that the height of the countersink 12 is significantly reduced from typical beverage can ends 2. By eliminating the depth of the countersink 8 with regard to the crown 14, significant material savings between about 2.5% and 11% have been realized. The relationship between the height of the countersink 8, the angle of the chuck wall  $\theta$ , and the diameter of the center panel 10 can generally be described with the following formula which is additionally shown in FIG. 9:

$$D2 = 2 \times (A - B) \times \tan(\theta) \text{ plus } D1 \text{ where}$$

[0032] a) D1 equals the starting panel radius center diameter;

[0033] b) D2 equals the final panel radius center diameter;

[0034] c)  $\theta$  equals the chuck wall angle;

[0035] d) A equals the starting countersink length; and

[0036] e) B equals the final countersink length.

[0037] Referring now to FIG. 1, four different embodiments of the present invention are provided herein which depict ranges of the countersink depth, the chuck wall angle  $\theta$ , the height of the center panel 10, and the overall diameter of the central panel 10. As shown, as the height from the crown 14 to the countersink 8 is reduced, the diameter of the central panel 10 increases.

[0038] In each of the specific embodiments shown in FIGS. 2-5, the height between the lowermost portion of the countersink 8 and the height of the central panel 10 is generally about 0.090 inches, although there may be variations depending on other geometric features of the beverage can end 2. Further, as shown in FIG. 1 the panel height above the lowermost portion of the countersink 8 may generally have a range of between about 0.030 and 0.130 inches. As seen in FIG. 1, the inner panel wall 12 is oriented at an angle  $\phi$  in a substantially vertical direction when extending upwardly from the countersink 8, but may have an angle of between about 0-10 degrees or be arcuate in shape as previously discussed. Further, the countersink radius in a preferred embodiment is estimated to be between 0.010 to

0.020 inches, while the radius of the interconnection between the central panel **10** and the inner panel wall **12** is preferably between about 0.010 inches to 0.030 inches. As further identified in **FIG. 1**, the distance from the crown **14** in one embodiment is 0.130 inches to the lowermost portion of the countersink **8**, and in other embodiments is 0.150 inches, 0.180 inches and 0.270 inches as shown. Preferably with all of the embodiments described herein, the gage of the metallic material (typically aluminum) is between about 0.0050 and 0.0140.

[0039] More specifically, **FIG. 2** represents a beverage can end **2** with a countersink of about 0.130 inches as measured from the crown **14** to the lowermost portion of the countersink **8**. In this particular embodiment, with a  $12^\circ 45'$  chuck wall angle  $\theta$ , the central panel has a diameter of 1.879 inches as measured to the point of curvature of the central panel **10** or a diameter of about 1.936 inches to the vertical inner panel wall **12**. The height of the central panel **10** in all embodiments shown in **FIGS. 2-5** have a distance from the lowermost portion of the countersink **8** of about 0.090 inches. In this particular embodiment, it has been found that a material reduction of about 10.95% can be realized over more conventional beverage can ends with more pronounced countersink **8** depths.

[0040] Referring now to **FIG. 3**, an alternative embodiment of the present invention is provided herein with a counter sink depth of 0.150 inches as measured from the height of the crown **14**. In this embodiment, the outermost diameter of the central panel **10** is about 1.927 inches, with a chuck wall angle  $\theta$  of  $12^\circ 45'$ . Further, the radius at the intersection between the inner panel wall **12** and the central panel **10** is 0.020 inches, which is consistent with the other embodiments shown in the **FIGS. 2-5**. In this particular embodiment, a material reduction of about 9.46% is realized as compared to conventional beverage can ends.

[0041] Referring now to **FIG. 4**, an alternative embodiment of the present invention is described herein with a height from the crown **14** to the lowermost portion of the countersink **8** of about 0.180 inches. In this embodiment, with the central panel **10** elevated above the lowermost portion of the countersink a distance of about 0.090 inches, and with a chuck wall angle  $\theta$  of  $12^\circ 45'$ , the central panel has an outermost diameter of 1.913 inches as measured to the respective inner panel walls **12**. Furthermore, in this particular embodiment the material reduction is estimated at about 7.05% over conventional beverage can ends.

[0042] Referring now to **FIG. 5**, a prior art beverage can is provided herein for reference purposes with respect to **FIGS. 1-4**. This drawing further identifies the significant reduction in the depth of the countersink **8**.

[0043] Referring now to **FIGS. 6-6B**, three alternative embodiments of the present invention are shown herein. More specifically, **FIG. 6** shows one embodiment of the present invention, wherein the central panel **10** is elevated above the crown **14** of the circular end wall **4**. **FIG. 6A** represents an alternative embodiment, wherein the crown **10** is positioned substantially at the same height as the crown **14** of the circular end wall **4**, while **FIG. 6B** is an embodiment more consistent with the embodiments shown in **FIGS. 1-5**, wherein the central panel **10** is positioned below the crown **14** of the circular end wall **4**, but the countersink **8** depth from the crown **14** is still significantly reduced from prior art metallic beverage can ends.

[0044] Referring now to **FIG. 7**, another embodiment of the present invention is provided wherein the central panel **10** is shown elevated above the crown **14** of the circular end wall **4**, and which further includes a pull tab **18** positioned below and uppermost edge of the central panel **10** to selectively open the beverage can end. In this particular embodiment, the elevation of the central panel **10** above the crown **14** has at least two distinct advantages over prior art designs where the central panel **10** is positioned below the crown **14**. First, by creating a convex shaped central panel **10**, significant improvements in burst and buckle resistance have been obtained, with improvements estimated at between 2-10%. Thus, greater strength characteristics can be realized by using a substantially convex geometric configuration. Furthermore, to provide for stackability of the beverage can ends **2** prior to filling and double seaming with the beverage can body, the pull tab **18** is positioned below an uppermost portion of the central panel **10** in a deboss or indentation **20** of about 0.070 inches. As appreciated by one skilled in the art, numerous types of pull tabs **18** or other opening devices may be used as preferred by the filler or customer.

[0045] The second distinct advantage provided with the design shown in **FIG. 7** is the increased head-space created by the elevated central panel **10**. The head-space is generally defined herein as the distance above the beverage in the beverage can body and the central panel **10**, which allows for expansion within the can due to freezing and/or excessive pressure. By increasing the amount of available head-space, the beverage can body **16** may be reduced in height, thus substantially saving materials and associated costs in the beverage can body **16**.

[0046] Referring now to **FIG. 8**, two embodiments of the present invention are shown overlaid herein, as well as a more typical prior art beverage can for comparison purposes. More specifically, the beverage can identified as "A" is shown with a substantially arcuate shaped central panel **10**, which extends upwardly from the inner panel wall **12** and countersink **8**. The central panel **10** is curved inwardly but is raised above the crown **14** of the circular end wall **4**. As further identified in this drawing, the pull tab **18** is positioned below an uppermost edge of the central panel **10**. A second embodiment of the present invention as shown in **FIG. 8** is identified by "B" which shows the central panel **10** having an arcuate shape and a pronounced radius of curvature but which is oriented inwardly at a more accelerated rate than the embodiment shown in "A". Furthermore, with the embodiment shown in "B", the indentation **20** of the central panel **10** is positioned further inwardly, and thus having slightly less clearance between the pull tab **18** and the central panel indentation **20**.

[0047] Referring now to **FIG. 9**, a front elevation view of one embodiment of the present invention is provided herein and which additionally depicts the various parameters used to calculate the final panel radius diameter shown as  $D_2$  and also defined previously in the equation on page 7. More specifically, the parameters include the starting panel radius center diameter  $D_1$ , the chuck wall angle  $\phi$ , the starting countersink length  $A$ , and the final countersink length  $B$ . With these parameters and associated formula, it is thus possible to vary numerous parameters to define a beverage can end **2** with a given central panel diameter, angle of chuck wall  $\theta$ , etc.

[0048] Referring now to FIGS. 10 and 11, a front perspective view of two embodiments of the present invention are provided herein, wherein the central panel 10 is raised above the crown 14 of the circular end wall 4. Further, FIG. 11 shows the invention depicted in FIG. 10, but also including a pull tab 18 which is positioned below the upper edge of the central panel 10 and positioned within a central panel indentation 20 commonly known in the art as the deboss. By positioning the pull tab 18 in the central panel indentation 20, the stackability of the beverage can ends may be maintained for shipment in bulk.

[0049] For clarity purposes, the following lists of components and the associated numbering in the drawings are provided herein:

No.	Components
2	Beverage can end
4	Circular end wall
6	Chuck wall
8	Countersink
10	Central panel
12	Inner panel wall
14	Crown
16	Beverage can body
18	Pull tab
20	Central panel indentation
$\theta$	Chuck wall angle
$\phi$	Inner panel wall angle

[0050] The foregoing description of the present invention has been presented for purposes of illustration and description. Furthermore, the description is not intended to limit the invention to the form disclosed herein. Consequently, variations and modifications commenced here with the above teachings and the skill or knowledge of the relevant art are within the scope in the present invention. The embodiments described herein above are further extended to explain best modes known for practicing the invention and to enable others skilled in the art to utilize the invention in such, or other, embodiments or various modifications required by the particular applications or uses of present invention. It is intended that the dependent claims be construed to include all possible embodiments to the extent permitted by the prior art.

What is claimed is:

1. A metallic beverage can end having a reduced countersink, comprising:

- a substantially circular end wall adapted for interconnection to a can body and having a crown defined by an uppermost edge;
- a chuck wall integrally interconnected to said substantially circular end wall on an upper end and extending downwardly therefrom at a chuck wall angle  $\theta$ ;
- a substantially concave countersink interconnected to a lower end of said chuck wall, wherein a lowermost portion of said countersink is no greater than 0.270 inches from said crown;

an inner panel wall interconnected to said countersink and extending upwardly therefrom;

a central panel supported by said inner panel wall; and

an opening means in operable engagement with said central panel, wherein the metallic beverage can end can be selectively opened.

2. The metallic beverage can of claim 1, wherein said central panel is raised above said crown of said substantially circular end wall.

3. The metallic beverage can of claim 2, wherein said opening means is positioned below an uppermost edge of said central panel.

4. The metallic beverage can of claim 1, wherein said central panel is elevated between about 0.030 and 0.130 inches above said lowermost portion of said countersink.

5. The metallic beverage can end of claim 1, wherein said chuck wall angle  $\theta$  is between about 0 degrees and 20 degrees as measured from an imaginary vertical plane.

6. The metallic beverage can end of claim 1, wherein said beverage can end is comprised of a metal material having a gage thickness of between about 0.0050 and 0.0140.

7. The metallic beverage can end of claim 1, wherein a diameter of said central panel is reduced in size as a lowermost portion of said countersink increases in distance from said crown.

8. The metallic beverage can end of claim 1, wherein said central panel has a diameter no greater than about 1.936 inches when said lowermost portion of said countersink is no greater than 0.130 inches from said crown.

9. The metallic beverage can end of claim 1, wherein said countersink has a radius of curvature no greater than about 0.020 inches.

10. The metallic beverage can end of claim 1, wherein at least a portion of said central panel has an arcuate, non-linear cross-sectional shape.

11. The metallic beverage can end of claim 1, wherein said point of interconnection between said central panel and said inner panel wall has a radius of curvature no greater than about 0.020 inches.

12. A metallic beverage can end adapted for interconnection to a beverage can body, comprising:

a circular end wall having a crown defined by an uppermost edge of said circular end wall;

a chuck wall integrally interconnected to said end wall and extending downwardly at a chuck wall angle  $\theta$  of between about 0-20 degrees;

a substantially concave countersink integrally interconnected to a lower end of said chuck wall, said countersink having a lowermost portion which is no greater than about 0.270 inches in a vertical direction from said crown;

an inner panel wall integrally interconnected to said countersink and extending upwardly therefrom;

a central panel integrally interconnected to said inner panel wall and having a height at least about the same elevation as said crown of said circular end wall; and

an opening tab operably engaged to said central panel, wherein said beverage can end can be selectively opened.

13. The metallic beverage can end of claim 12, wherein said opening tab is positioned below an uppermost edge of said central panel.

14. The metallic beverage can end of claim 12, wherein at least a portion of said central panel has an arcuate, non-linear cross-sectional shape.

15. The metallic beverage can end of claim 12, wherein said beverage can is comprised of a material having a thickness no greater than 0.0090 inch gage.

16. The metallic beverage can end of claim 12, wherein said countersink has a radius of curvature no greater than about 0.030 inches.

17. The metallic beverage can end of claim 12, wherein said inner panel wall extends upwardly at an angle  $\phi$  of between about 0 and 10 degrees.

18. The metallic beverage can end of claim 12, wherein at least a portion of said central panel is raised above said crown and a portion is positioned at an elevation no greater than the elevation of said crown.

19. The metallic beverage can end of claim 12, wherein when said beverage can end is double-seamed to a beverage can body a head-space is created of at least about \_\_\_\_\_ inches.

20. A beverage can end adapted for interconnection to a beverage can body, comprising:

a circular end wall adapted for interconnection to a beverage can body, said circular end wall having a crown on an upper most edge;

a chuck wall integrally interconnected to said circular end wall and extending downwardly therefrom at a chuck wall angle  $\theta$  of between about 0 and 20 degrees;

a countersink integrally interconnected to said chuck wall and extending downwardly therefrom;

a central panel integrally interconnected to said countersink and extending upwardly therefrom to an elevation at least about the elevation of said crown; and

an opening means positioned on said central panel which is positioned at an elevation no greater than said uppermost edge of said central panel, wherein the beverage can may be selectively opened.

21. The beverage can end of claim 20, wherein said opening means comprises a pull tab.

22. The beverage can end of claim 20, wherein a lowermost portion of said countersink is no greater than about 0.270 inches from said crown.

23. The beverage can end of claim 20, wherein at least a portion of said central panel has a non-linear, arcuate shape.

\* \* \* \* \*