

J. BLACKIE.  
MAGNETIC ANNUNCIATOR.

No. 43,633.

Patented July 26, 1864.

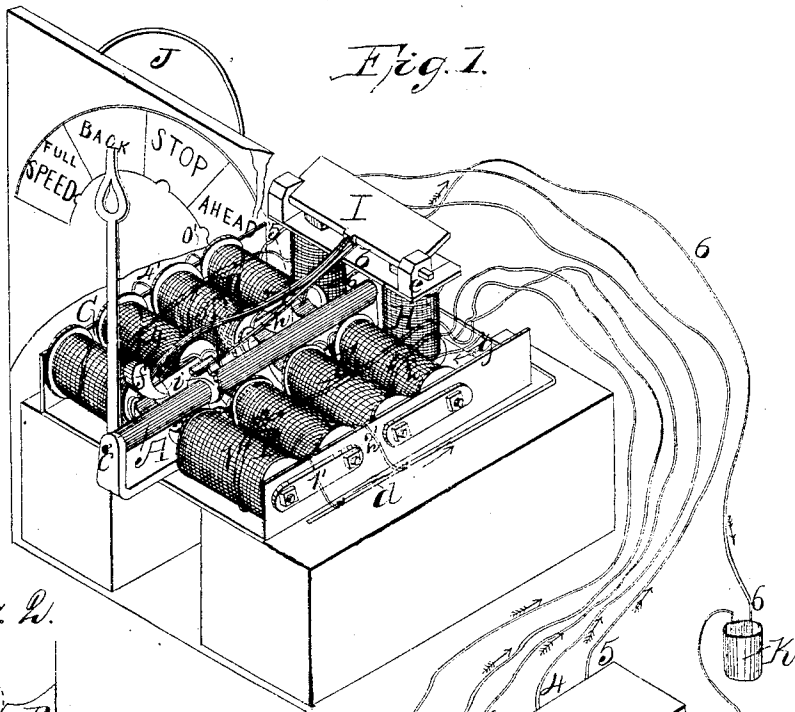

*Fig. 1.*



*Fig. 2.*

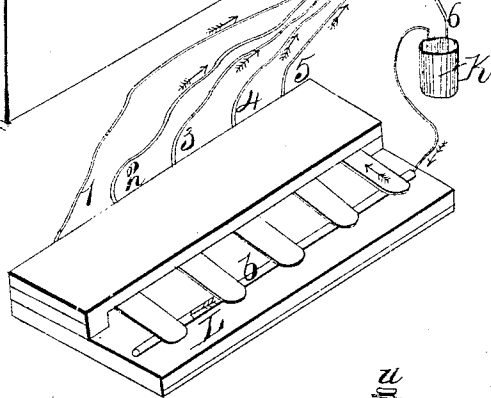

*Fig. 3.*

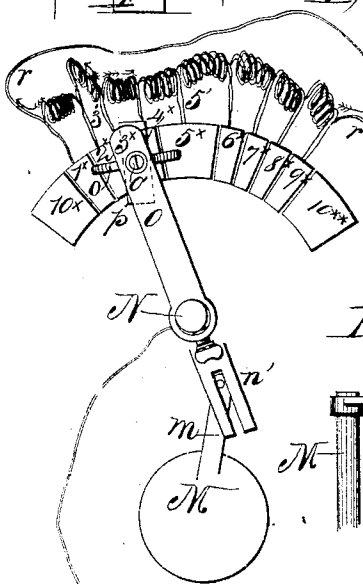

*Fig. 4.*

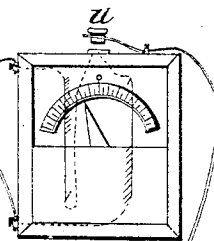
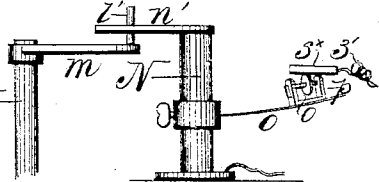

*120 Smith  
Ed. Wilkin*

*Witnesses:*



*Inventor  
John Blackie*

# UNITED STATES PATENT OFFICE.

JOHN BLACKIE, OF WASHINGTON, DISTRICT OF COLUMBIA.

## IMPROVEMENT IN MAGNETIC ANNUNCIATORS.

Specification forming part of Letters Patent No. 43,633, dated July 26, 1864.

To all whom it may concern:

Be it known that I, JOHN BLACKIE, a native of Scotland, now a resident of Washington city, county of Washington, and District of Columbia, have invented certain new and useful improvements in apparatus for conveying orders and signals by means of electricity, to be used on vessels or elsewhere, wherever the same may be applicable; and I do hereby declare that the following is a full, clear, and exact description of the same, reference being had to the accompanying drawings, making part of this specification, and to the letters of reference thereon.

Figure 1 is a perspective view, and Fig. 2 a transverse vertical section, of a portion of the apparatus for conveying orders to the helmsman or other party, as required. Fig. 3 is a bottom-plan view, and Fig. 4 a side elevation, of the device connected with and operated by the rudder for conveying return-signals to the pilot or other officer, as may be desired.

Similar letters in each of the figures indicate corresponding parts.

In Figs. 1 and 2, A represents an armature made long and round, as shown, and hung eccentrically upon pivot-points at each end, as shown at *c*, Fig. 2, so as to permit A to turn upon its pivots in either direction when attracted by an electro-magnet.

To one end of A is secured a pointer or index, which may be of such weight as to counterbalance the eccentrically-hung armature, by which means the latter may be operated by a very small power. By turning the armature A on its pivots the hand or index *a* will be made to move in the arc of a circle corresponding with the movement of A. By providing a dial-plate, and locating it so that the hand *a* shall sweep across its face, it is obvious that the hand may be made to move to or past any required numbers or signals painted or printed thereon, said signals or orders being, of course, arranged in the arc of a circle corresponding with the sweep of the hand.

I cause the armature A and hand *a* to assume as many different positions as there are orders to be conveyed, and this I accomplish by means of electro-magnets having their ends arranged or located radially around said armature A, in positions corresponding with the relative positions which the hand is required to

assume, in order to point to the various orders on the dial. It is immaterial what position the body of these magnets occupies, provided their faces or ends are properly located, as the armature will be attracted by the flat face of the end presented to it when the electrical current is applied without reference to the position of the body of the magnet. Availing myself of this principle, I so construct the bodies of the magnets B, C, D, and E that while occupying the same plane their ends shall be presented toward A in different positions radially, whereby A can be readily attracted or moved from one to another of the magnets, accordingly as the circuit is broken with one and completed with the other of said magnets. By these means I am enabled to operate the armature A and hand *a* to any required extent by magnets arranged as shown in Fig. 1, the armature assuming the various positions required, as indicated in red lines in Fig. 2. In this case I have located four magnets horizontally, two on each side of A, while the fifth magnet, F, is shown located underneath A in a vertical position, as shown in Fig. 2; but it is obvious that the body of F may also be placed horizontally, provided its ends are brought underneath A. It is further obvious that any desired number of magnets may be thus arranged, and the hand *a* made to assume a corresponding number of positions, the principle being the same as illustrated in Fig. 2.

Another magnet, H, is arranged vertically near the rear end of A, having secured to its upper end the plate *b*, which is provided with the projections *e*, through which pivot-points extend, pivoting the armature or keeper I thereto. To this keeper I is attached a rod having a hammer, *f*, secured to its opposite end, for the purpose of striking a bell, J, properly located, so as to attract the attention of the helmsman whenever the index is moved. As this method of constructing and operating the keeper I is intended to be made the subject of a separate application for Letters Patent its further description here is intentionally omitted.

In order to hold A and *a* in position, the armature A has attached to it a notched wheel, *i*, into the notches of which the spring-rod *h* falls when the hammer drops, thus holding A securely in position, and thereby retaining the

index *a* at the desired order marked on the dial: Attached to *h* is a small vertical rod, *s*, having its upper end bent in the form of a hook, which rod *s* is of such a length that the hammer-rod, when raised almost up to the bell, shall engage in said hook, and thereby lift the rod *h* out of the notch in wheel *i*, whereby the armature is unlocked and permitted to rotate. As the hammer falls again by its own gravity the rod *s* is released, whereby *h* again engages in one of the notches of *i*, again locking *A* in place. The operation of this part of the apparatus is as follows: A battery, *K*, is provided, having a wire leading to a key-board, *L*, located within reach of the pilot. From the keys a separate wire runs to each magnet except the vertical one, *H*. When one of the keys is pressed down so as to come in contact with the conductor *l* from the battery, whereby the circuit which the fluid is to travel is closed, the magnet connected with said key becomes charged, and thereby attracts the armature *A*, and, of course, moving the index *a*. The current at the instant of charging the magnet, by passing along the wire No. 1, for example, returns from the other arm of the magnet *D* by the wire *1'*, and is conducted along the rod *d* in the direction of the arrow until it arrives at the wire *g*, which conveys it to and charges the magnet *H*, which, attracting the keeper *I*, causes the hammer *f* to strike the bell and raise the rod *h* out of the notch in wheel *i* all at one operation, the fluid returning from the opposite arm of magnet *H* by wire 6 to the battery in the usual manner. As the return-wire from each magnet *B*, *C*, *D*, *E*, and *F* is connected with rod *d*, which is connected with magnet *H* by rod *g*, and as there is no return-wire to the battery, except No. 6, which passes direct from *H* to the battery, it follows that whenever either key is touched, whereby either of the magnets operating *A* is charged, the current is compelled to pass around *H*, charging it at the same time. Thus the index is operated, the armature *A* unlocked and relocked, and the bell struck, all at one operation. By these means the pilot is at all times enabled to transmit instantly to the man at the wheel any of the orders marked on the dial, the latter being, of course, located where it can be constantly seen by the helmsman. In order, however, that the pilot may know that his order has been obeyed, it is necessary that some means shall be provided by which the position of the rudder shall be automatically indicated or made known to him. Figs. 3, 4, and 5 represent the device which I have invented for this purpose.

In Fig. 3, *M* represents the rudder-post, which has attached to it an arm, *m*, provided with a vertical pin, *l'*, which works in a slot in a similar arm, *n'*, attached to another shaft or rotating post, *N*. This post *N* is also provided with a spring-arm, *O*, which has secured to its upper side, near its outer end, an adjustable frame, *p*, in which is mounted a metallic roller, *o*. By having the frame *p* adjustable, or piv-

oted, as shown at *o'*, it can be so turned as to cause the roller *o* to stand diagonally to its line of travel, as shown in Figs. 3 and 4. By these means the roller *o* is caused to scrape or slide to a limited degree at the same time that it rolls in moving over the face of the metallic plates 1\* 2\*, &c., the roller *o* being held firmly up against said plates by the pressure of the spring-arm *O*, as shown in Fig. 4. The series of plates from 1\* to 9\* are connected by conducting-wires, as shown in Fig. 4, from the from the extremities of which series of connecting-wires a separate wire, *r* and *r'*, is connected, leading to the differential galvanometer, Fig. 5, which, being a well-known device, is not therefore described.

The operation of this device is as follows: A wire from battery *R* leads to the shaft or post *N*, from whence the fluid passes along arm *O* to wheel *o*, from which it passes to either of the series of plates 1\* to 9\*, according as the wheel *o* may be in contact with one or the other of said plates. From said plate, which, as shown by the position of the roller *o* in Fig. 3, is plate 3\*, the electric current passes along wire 3' to the point where said wire is connected to the uniting-coils on either side, at which point the current is divided, and flows thence along both wires *r* and *r'* to the differential galvanometer, Fig. 5, from which it returns to the battery along wire *t*, when the circuit is closed by means of the knob *u*, Fig. 5. As the rudder *M* is turned to one or the other side the arm *O* and wheel *o* is made to move in a corresponding manner over the series of plates, as already described, whereby the circuit is closed between the wheel *o* and the plate upon which it rests. When the wheel rests upon plate 5\* it is obvious that the current, which is divided at the point where wire 5' unites with the connecting-coils, will have the same distance to travel along wires *r* and *r'*, the same being of uniform lengths, in which case the needle of the galvanometer will stand at zero; but whenever the connection is made between the wheel *o* and any other plate—as, for instance, with plate 3\*, as shown in the drawings—then the current passing to the right along wire *r'* will have a greater distance to travel than that portion passing to the left and along wire *r*, which will cause the needle to be deflected to a degree exactly corresponding with the difference in the distance traveled by the two currents. When the wheel *o* is carried to the opposite side of plate 5\* then the needle will be deflected to the opposite side in a similar manner. By these means the position of the rudder will at all times be indicated by the position of the needle whenever the circuit is closed at *u*, and thus the pilot in the pilot-house, the captain in his room or any other portion of the vessel where the galvanometer may be located, can at all times, day or night, and without the knowledge of the helmsman, know exactly at what angle or point the rudder stands.

It is obvious that the entire apparatus, or

either of the devices composing it, may be applied to other purposes and uses than that here shown, this application of it being one of the most useful and sufficient to illustrate my invention.

Having thus fully described my invention and its operation, what I claim as new, and desire to secure by Letters Patent, is as follows:

1. Operating an eccentrically-hung keeper or armature, A, by means of a series of magnets, substantially as herein set forth.

2. The stop *i*, in combination with the spring *h* or its equivalent, for the purpose of holding the keeper A and index *a* in position. —

3. Operating the catch *h* and hammer *f* by the keeper I, substantially as described.

4. The connecting-coils and series of plates

1\* 2\*, &c., in combination with a differential galvanometer, as shown and described.

5. The wheel *o*, mounted in the adjustable frame *p*, operated by the spring-arm O and shaft N, in combination with the series of plates 1\* 2\*, &c., as described.

6. Connecting an operating-shaft, N, with the rudder-post M by means of the slotted arm *n'*, arm *m*, and pin *l'*, by which means the vertical movement of the rudder-post is prevented from disarranging or interfering with post N and its attachments.

JOHN BLACKIE.

Witnesses:

W. C. DODGE,

JOHN S. HOLLINGSHEAD.