

FIG. 1

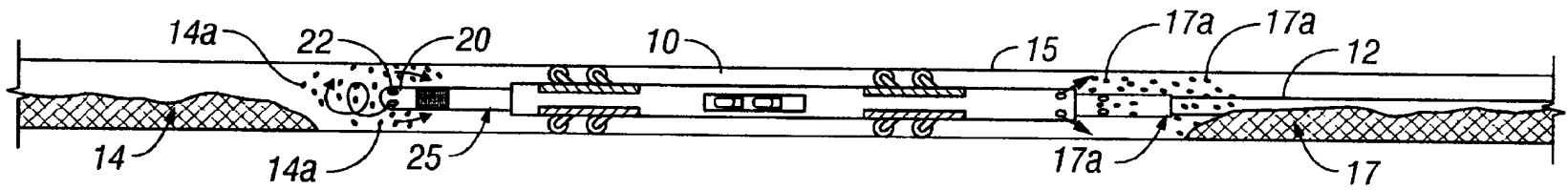

FIG. 2

1/6

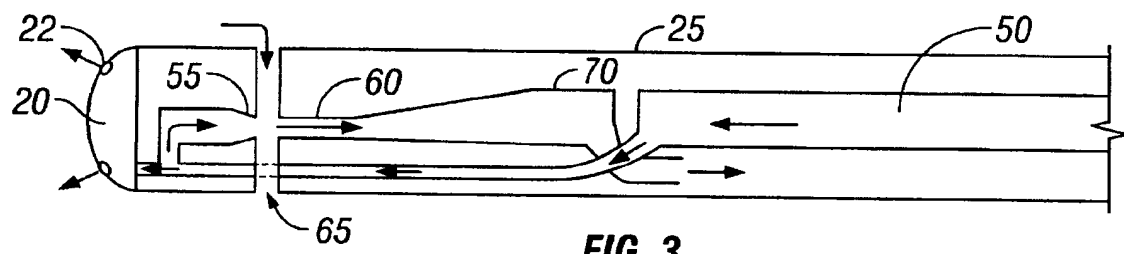

FIG. 3

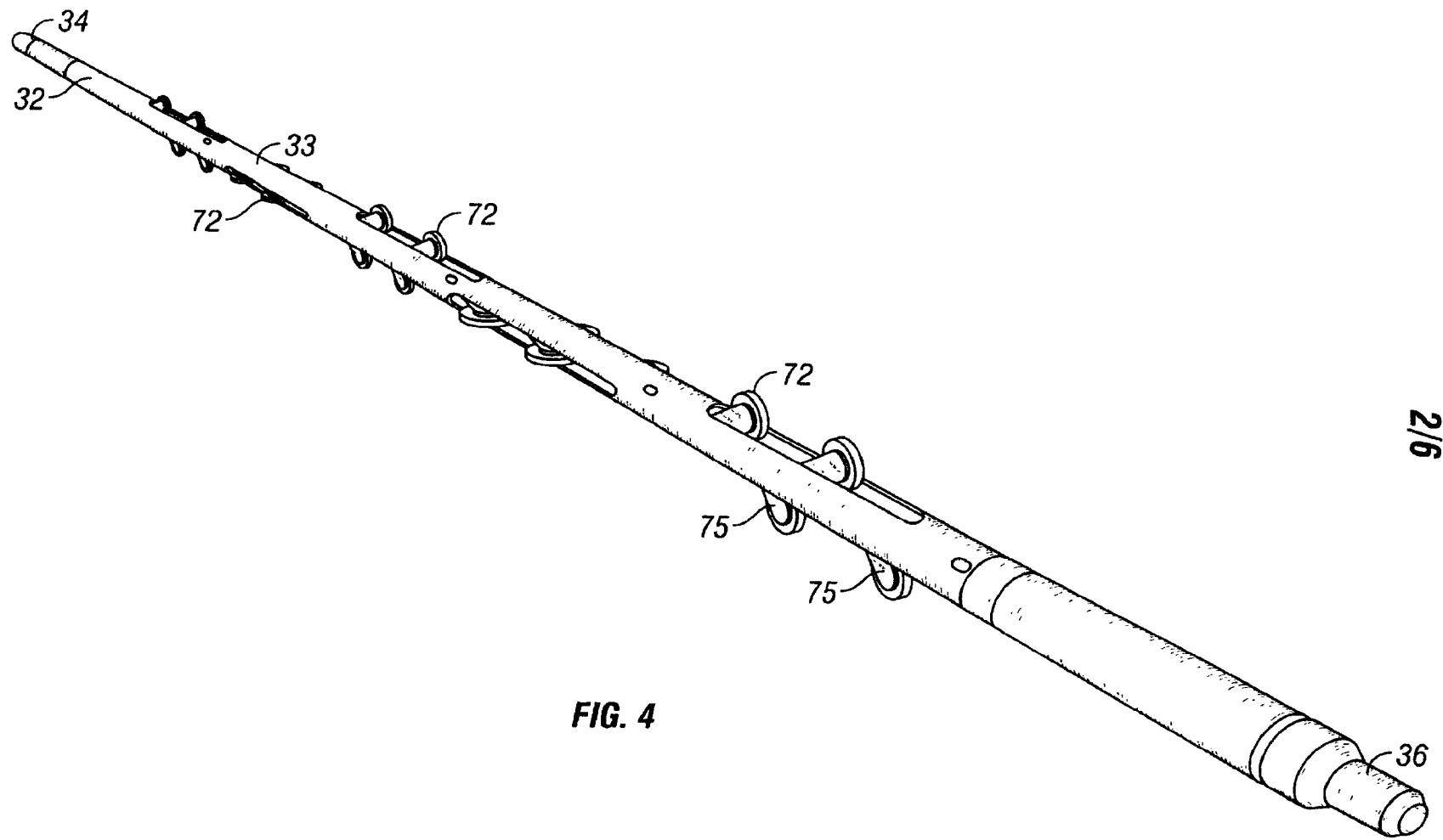
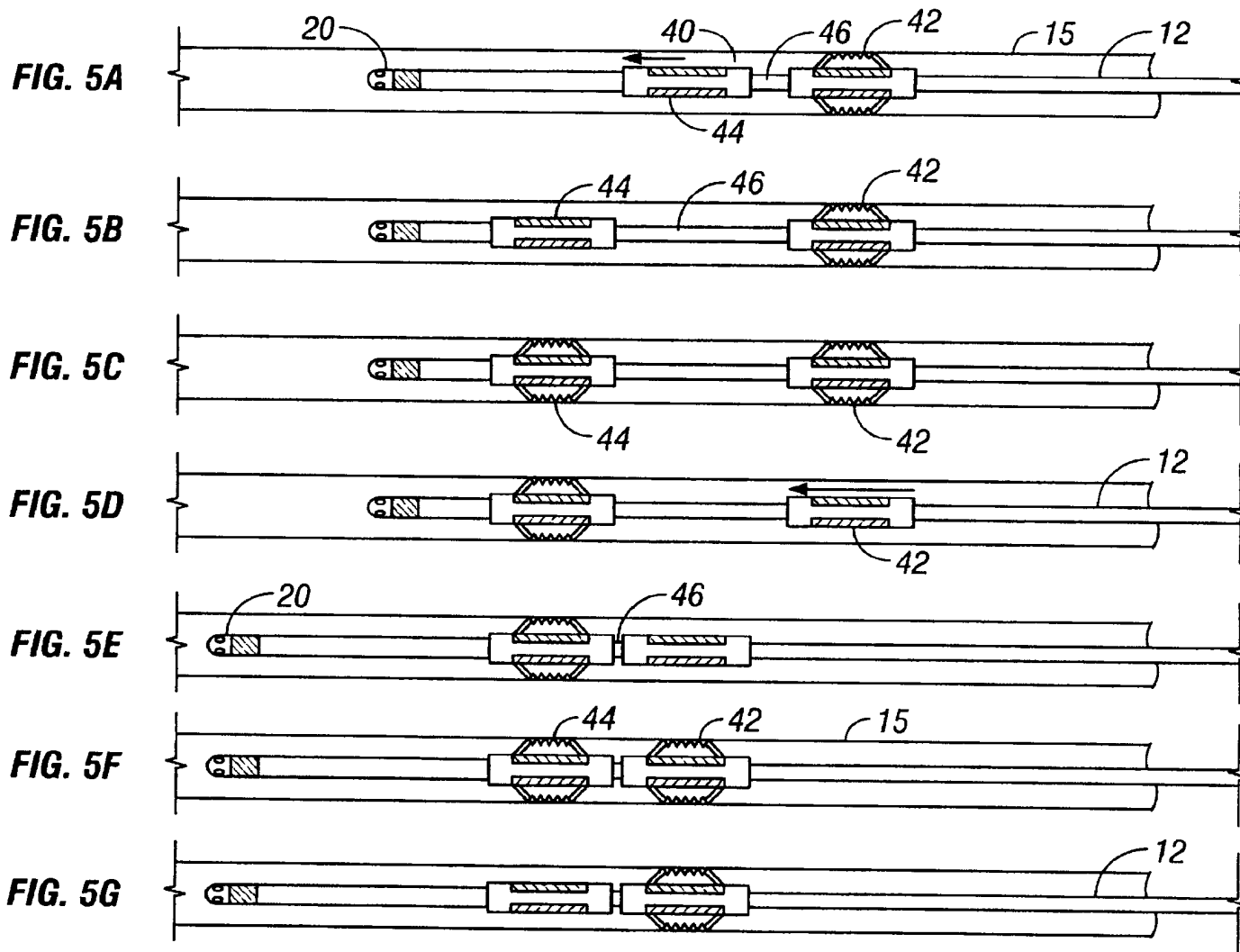

FIG. 4



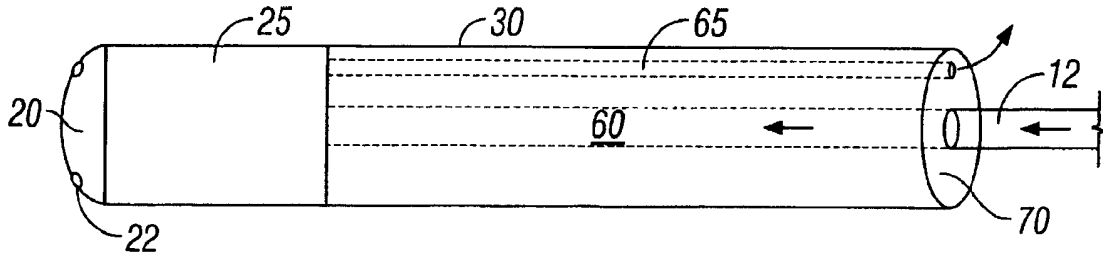

FIG. 6

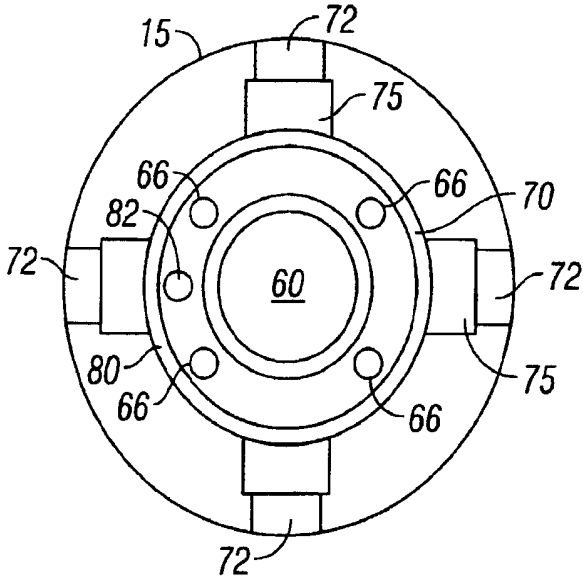

FIG. 7

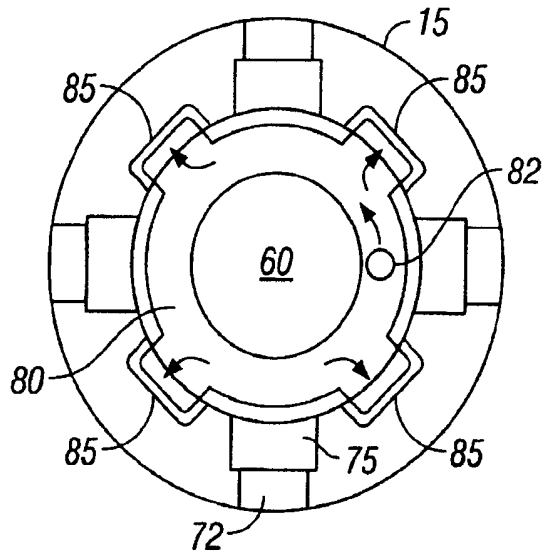

FIG. 8

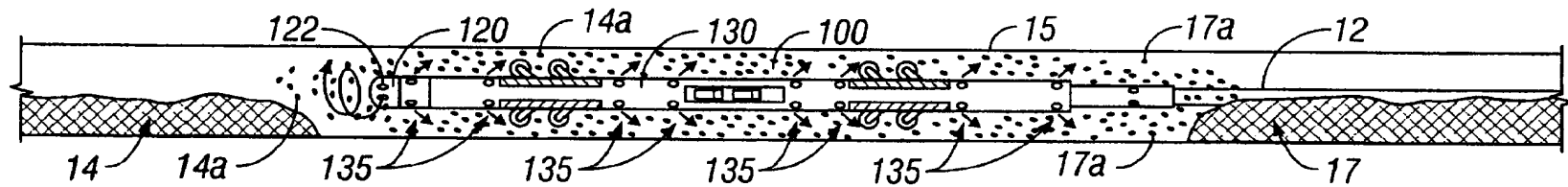

FIG. 9

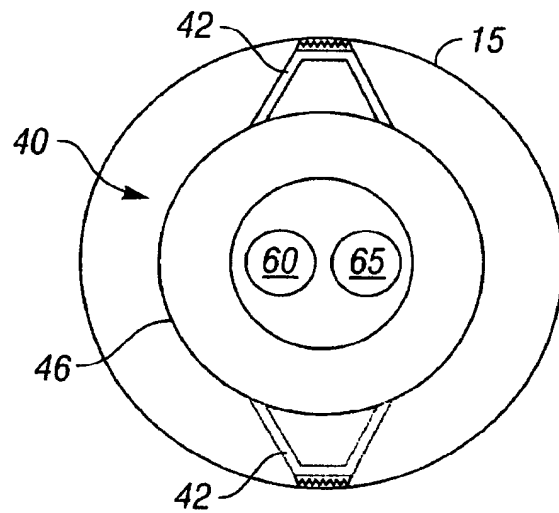

FIG. 10

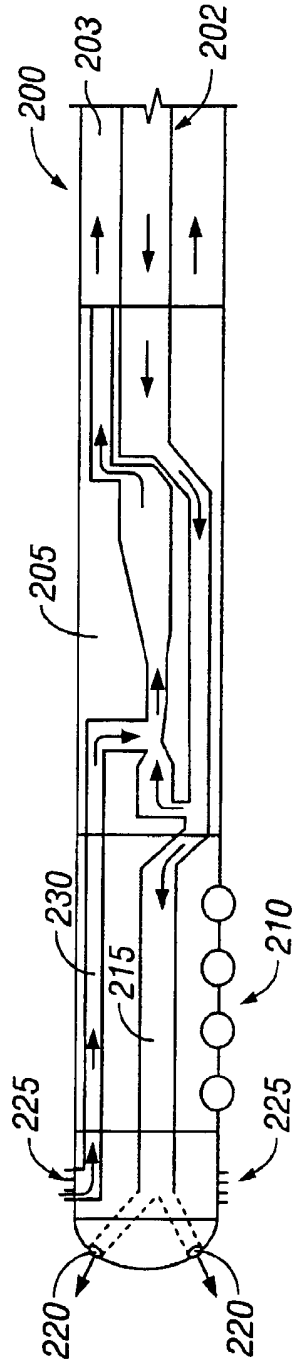

FIG. 11

APPARATUS TO FACILITATE A COILED TUBING TRACTOR TO
TRAVERSE A HORIZONTAL WELLBORE

The present invention is directed to apparatus and methods for removing sand and/or other fill material located in a wellbore ahead of a coiled tubing tractor and displacing the material behind the tractor. More particularly, the apparatus and methods of the present invention allow a coiled tubing tractor to drive forward in a wellbore by the removal of fill material in front of the tractor thereby allowing the wheels or traction pads of the tractor to remain in contact with the wellbore.

Operators are drilling an increasing number of long reach horizontal wells to better access remote reserves. Many of these "extended reach" wells have passed the limit where unaided re-entry to TD is possible with practical sizes of coiled tubing. The industry has responded by developing hydraulically powered tractors that can be attached to the bottom of the coiled tubing for the purpose of pulling the coiled tubing along the horizontal section of the well. This technology is relatively new and only a few CT tractor jobs have been attempted to date but there is some concern that the reliability of the technology could be seriously compromised by significant quantities of sand or fill material on the low side of the hole. The unanswered question is how reliably can the different tractor types perform when they are trying to drive their wheels or traction pads through a substantial sand bed?

Sand beds on the low side of the wellbore represent a potentially significant obstacle. For example, a 3 inch (7.6cm) deep sand bed in a 6¼ inch (15.9cm) hole could cause a tractor to begin pushing the sand ahead of it until a point is reached where the tool becomes stuck

in the wellbore. Thus, there is a need for a way to clear the wellbore of sand or fill in the immediate vicinity ahead of the tractor so the tractor does not have to attempt to negotiate through and/or over such an obstacle. Although sand typically is the most prevalent wellbore fill material, it shall be understood that use of the term "sand" hereinafter shall also include any other wellbore particulates such as drill cuttings, metal shavings and wellbore fines.

10 The present invention employs a series of forward and rearward angled jetting assemblies that can be attached to or configured within the coiled tubing tractor itself. The leading assembly has forward angled nozzles to fluidize the sand bed ahead of the tractor plus a series of rearward angled nozzles that maintain the sand in turbulent suspension for a sufficient distance to ensure that the sand settles behind the tractor. The objective is to remove sand from the specific area in the well where the tractor is situated and allow it to deposit behind the tractor. The tractor itself would thus be operating in a portion of the wellbore that is largely unobstructed by any sand bed. Depending on the tractor length it may be necessary to include several rearward jet nozzles at strategic intervals along the tractor length to ensure that sand is carried the required distance. The addition of polymers in the circulating fluid may aid in the temporary suspension of sand and thus reduce the requirement for multiple rearward nozzle assemblies.

30 An alternative embodiment uses a jet pump to suck in the fluidized sand and vigorously expel the sand in the rearward direction. The fluidized sand discharge would either be directly into the annulus around the tractor or

preferably through a separate return fluid passageway running substantially the full length of the tractor. Preferably this return fluid passageway is engineered within the tractor itself but, if wellbore and tractor dimensions permitted, it may be attached to the outside of the tractor. The tractor would in effect "burrow" along the well while pulling the coiled tubing behind it. Any in-line, pump-through tool having rearward facing jetting nozzles, such as the Tornado™ tool offered by BJ Services Company, could be run behind the tractor without compromising the washing action around the tractor. When the drag of the sand on the coiled tubing reached the pull limit of the tractor, a wiper trip would be initiated and the sand beds behind the tractor could be swept out of the hole by the rearward facing nozzles of the pump-through tool after which forward progress along the wellbore could be re-initiated.

One embodiment of the present invention is directed to a wellbore tractor comprising a tractor body, a central fluid passageway extending through the length of the tractor body, a return fluid passageway and a means for driving the tractor through the wellbore. The return fluid flow passageway further comprises one or more flow conduits that may extend longitudinally through at least a portion of the wall of the tractor body. Alternatively, the one or more flow conduits may comprise one or more external flow channels extending along at least a portion of the outer surface of the tractor body. Preferably, the external flow channels are attached between the means for driving the tractor.

In an alternative embodiment of the invention, a wellbore tractor is provided having a tractor body, a central fluid passageway extending through the length of

the tractor body, one or more rearward facing jet nozzles extending through the tractor body and in fluid communication with the central fluid passageway, and a means for driving a tractor through the wellbore.

5 A method of moving a coiled tubing tractor through a wellbore is also provided comprising the steps of running a coiled tubing tractor assembly on coiled tubing into the wellbore, wherein the tractor assembly comprises one or more forward facing nozzles, a jet pump and the tractor. The method further comprises removing one or more sand beds ahead of the tractor by fluidizing the sand particles with the one or more forward facing jet nozzles to create a sand-laden slurry, pumping the sand-laden slurry via the jet pump past the trailing end of the tractor and driving the tractor through a portion of the wellbore that previously contained one or more sand beds. The method further comprises circulating and/or sweeping the sand out of the wellbore, preferably while pulling out of the hole with the coiled tubing tractor assembly with one or more rearward facing nozzles located between the tractor and the coiled tubing.

15 Another method of moving the coiled tubing tractor to the wellbore comprises the steps of running a coiled tubing tractor assembly on a coiled tubing into the wellbore, the tractor assembly comprising one or more forward facing jet nozzles, the tractor and one or more rearward facing jet nozzles. The method further comprises the steps of removing one or more sand beds ahead of the tractor by fluidizing the sand particles with the one or more forward facing jet nozzles, maintaining the sand in fluid suspension with the rearward facing jet nozzles until the sand particles settle behind the tractor and driving the tractor through

the portion of the wellbore that previously contained the one or more sand beds.

Another embodiment of the invention is directed to a coiled tubing tractor assembly comprising a forward jetting assembly operable to fluidize sand beds ahead of the coiled tubing tractor, the coiled tubing tractor having a tractor body, a central fluid passageway and a return fluid passageway. The assembly also comprises a jet pump connected between the forward jetting assembly and the tractor, wherein the jet pump is operable to pump the fluidized sand through the return fluid passageway to expel the fluidized sand past the trailing end of the tractor. The assembly may further comprise a rearward facing jetting tool operable to circulate or sweep the sand behind the tractor out of the wellbore. The assembly may comprise a fluid manifold in fluid communication with the return fluid passageway.

An alternative assembly comprises a forward jetting assembly operable to fluidize sand beds ahead of a coiled tubing tractor, the coiled tubing tractor having a tractor body, a central fluid passageway extending through the tractor body, and one or more rearward facing jet nozzles extending through the tractor body and in fluid communication with the central fluid passageway wherein the rearward facing nozzles are operable to maintain the sand in fluid suspension until the sand travels past the tractor.

Another embodiment of the invention is directed to a method of moving a coiled tubing tractor through a wellbore containing sand, comprising the steps of running a coiled tubing tractor assembly on coiled tubing into the wellbore, the tractor assembly comprising one or more forward facing jet nozzles, the tractor, a suction inlet

ahead of the tractor and a jet pump behind the tractor, the jet pump being in fluid communication with the suction inlet. The method further comprises removing a sand bed ahead of the tractor by fluidizing the sand particles with the one or more forward facing nozzles to
5 create a sand-laden slurry; sucking the sand-laden slurry through the suction inlet; pumping the sand-laden slurry via the jet pump past the trailing end of the tractor assembly; and driving the tractor through the
10 portion of the wellbore that previously contained the sand bed. The tractor assembly may be run into the wellbore on a concentric coiled tubing wherein the sand-laden slurry is pumped to the surface via the annulus between the inner and outer coiled tubings in the
15 concentric coiled tubing string.

Still another embodiment of the invention is directed to a coiled tubing tractor assembly comprising one or more forward facing jet nozzles operable to fluidize sand beds ahead of a coiled tubing tractor, the
20 coiled tubing tractor having a tractor body, a fluid passageway for delivering fluids to the one or more jet nozzles and a return fluid passageway. The tractor assembly further comprises a suction inlet between the one or more jet nozzles and the tractor and a jet pump
25 located behind the tractor wherein the return fluid passageway provided fluid communication between the suction inlet and an inlet port on the jet pump, the jet pump being operable to pump the fluidized sand past the trailing end of the tractor assembly.

30 The present invention could also be used to move a coiled tubing tractor through a flowline, such as a water or petroleum pipeline, that contains particulate matter. The particulate matter in the flowline would be moved

from in front of the tractor and displaced to a position behind the tractor in a similar manner as described in a wellbore.

For a better understanding of the present invention, reference will now be made, by way of example, to the accompanying drawings, in which:

5 Figure 1 illustrates a coiled tubing tractor assembly in accordance with the present invention in a horizontal wellbore;

10 Figure 2 illustrates the coiled tubing tractor assembly shown in Figure 1 being moved through a horizontal wellbore having sand beds on the low side of the wellbore;

Figure 3 illustrates a cross section of a conventional jet pump connected to a forward jetting assembly;

15 Figure 4 is a perspective view of a prior art coiled tubing tractor;

Figures 5A-G illustrate a caterpillar-type down hole tractor moving through a horizontal section of a wellbore;

20 Figure 6 is a side view of an improved wellbore tractor in accordance with the present invention;

Figure 7 is an end view of an improved, wheeled wellbore tractor having a plurality of flow conduits extending longitudinally through the wall of the tractor body;

25 Figure 8 is an end view of an improved, wheeled wellbore tractor having a plurality of external flow channels extending longitudinally along the external surface of the tractor body;

30 Figure 9 illustrates an alternative coiled tubing tractor assembly in accordance with the present invention being moved through a horizontal wellbore having sand beds on the low side of the wellbore;

Figure 10 is an end view of a caterpillar type

tractor having a return fluid passageway arranged side-by-side with the power fluid conduit; and

Figure 11 illustrates another embodiment of a coiled tubing tractor assembly in accordance with the present invention.

Figures 1 and 2 illustrate a coiled tubing tractor assembly in accordance with the present invention. A wellbore tractor assembly 10 is illustrated driving a coiled tubing string 12 through a horizontal section of wellbore 15 in the direction indicated by arrow 13. Coiled tubing tractor assembly 10 in Figure 1 comprises a forward facing jetting assembly 20, jet pump 25, coiled tubing tractor 30, and a rearward angled jetting assembly 35. In a preferred embodiment, forward facing jetting assembly 20 comprises one or more angled, stationary jet nozzles that create a swirling flow ahead of the nozzles when fluid is pumped down through the tractor assembly and out the nozzles. The angled stationary jet nozzles produce a tangential effect for the exiting jet stream. The swirling fluid flow disturbs the sand beds 14 located ahead of the tractor assembly and fluidizes the particles contained therein. Alternatively, forward facing jetting assembly 20 may comprise a rotating jetting head. An example of a rotating jetting head is the Rotojet™, commercially available from BJ Services Company.

Figure 3 illustrates a conventional jet pump suitable for working with the assembly illustrated in Figures 1 and 2. A conventional jet pump is a hydraulic pump with no moving parts. A power fluid is pumped down a central passageway 50 wherein a portion of the power fluid will exit the front of the pump, in this case through one or more forward facing jet nozzles 22 of jetting assembly 20 to fluidize the sand ahead of the

tractor assembly. The remaining portion of the power fluid is forced through a venturi jet nozzle 55 and into throat 60 of the jet pump. By way of example, $\frac{1}{4}$ of the power fluid may exit the pump to fluidize the sand and $\frac{3}{4}$ of the power fluid may be pumped through the venturi jet nozzle as illustrated by the arrows of Figure 3. The flow of fluid through the venturi jet nozzle and into the throat creates a suction pressure that sucks the fluidized sand into side inlet ports 65. The fluidized sand combines with the power fluid and enters into throat 60 of the jet pump. The power fluid and sand picked up by the jet pump continue through the diffuser 70 of jet pump 25 and the sand-laden slurry is pumped out of the trailing end of the jet pump. Typically, jet pumps are used to pump the sand-laden slurry completely out of the wellbore. With the embodiment illustrated in Figures 1 and 2, the jet pump is only used to pump the slurry past the tractor.

It is difficult to pick up solids from a sand bed at the bottom of a wellbore with a conventional jet pump alone. It is better to fluidize the sand particles of the sand bed such that the sand particles are suspended in the liquid. The sand slurry is then sucked into the jet pump and pumped up the wellbore. Accordingly, a preferred embodiment of the present invention utilizes a jet pump connected to and in fluid communication with a forward facing jetting assembly. The jet stream from nozzles 22 stir up the sand, fluidize the particles 14a and then the jet pump sucks the fluidized material into the fluid intake of the pump and pumps the slurry up the wellbore and past the tractor. The power fluid can be water, drilling mud or any other suitable liquid. The power fluid may include polymers to aid in temporarily

suspending the sand particles as the sand is transported from an area ahead of the tractor to an area behind the tractor. The transported sand 17a may form new sand beds 17 behind the tractor assembly.

5 Tractor 30 is connected to jet pump 25 in the tractor assembly illustrated in Figures 1 and 2. A coiled tubing tractor, such as the Well Tractor® from Weltec (as illustrated in Figure 4), utilizes a fluid driven turbine 32 to drive the internal hydraulic system
10 33. The hydraulic system of the Well Tractor® consists of two pressurized systems. The first system will force a plurality of wheel arms 75 out from the tractor body so that the wheels 72 of the tractor will contact the casing or borehole wall. The second system provides the driving
15 force for driving the tractor through the wellbore. Coiled tubing tractors are attached to coiled tubing and are activated when it is no longer possible to run the coiled tubing string into the wellbore with the coiled tubing injector. The tractor is activated by pumping
20 fluid through the tubing, into the tractor body and through the turbine. The tractor will drive the coiled tubing into the wellbore as long as the flow rate of the fluid through the tractor is maintained above a predetermined rate. Once the pumping of the wellbore
25 fluid falls below the predetermined rate, the wheels 72 will retract back into the body of the tractor. Preferably, once the tractor is deactivated, the wheels will retract into the body to leave a flush outside diameter. Tractor 30 includes top connector 34 and
30 bottom connector 36.

In an alternative embodiment, the coiled tubing tractor includes a pair of hydraulic grippers and a telescopic hydraulic cylinder as the means for driving

the tractor, and the coiled tubing it is pulling, into a wellbore. The All-Hydraulic Intervention Tractor (TM), offered by Western Well Tool, Inc., is a commercial example of the caterpillar-type wellbore tractor. Other
5 examples of caterpillar-type tractors are disclosed in U.S. Patents 6,003,606, 6,286,592, 6,230,813, 6,601,652, 6,241,031, 6,427,786, 6,347,674, 6,478,097 and 6,679,341, all of which are incorporated herein by reference. Figures 5A-G illustrate how the caterpillar-type downhole
10 tractor 40 works. In Figure 5A, rear gripping mechanism 42 is activated, the front gripping mechanism 44 is retracted, and the telescopic cylinder 46 is in the retracted position. Figure 5B illustrates the tractor when the rear gripping mechanism is activated, the front
15 gripping mechanism is retracted, and the telescopic cylinder is at full extension. Next, both the front and rear gripping mechanisms are activated while the telescopic cylinder is fully extended. In Figure 5D, the rear gripping mechanism is retracted and the telescopic
20 cylinder is retracting while the front gripping mechanism is activated. Once the telescopic cylinder is fully retracted, as shown in Figure 5E, the rear gripping mechanism is activated into gripping engagement with the wellbore (Figure 5F). Once the rear gripping mechanism
25 is activated, the front gripping mechanism is retracted and the telescopic cylinder is ready to be extended as illustrated in Figure 5G. The steps illustrated in Figures 5A-G are then repeated to move the tractor and coiled tubing down the wellbore. The tractor has a
30 central passageway extending longitudinally through the hydraulic cylinder of the tractor for receiving the power fluid. The central passageway is in fluid communication with the hydraulic system used to operate the tractor.

In a preferred embodiment, tractor 30, shown in Figure 6, includes a tractor body 70, a central fluid passageway 60 extending through the length of the tractor body, and a means for driving the tractor through the wellbore (not shown). The means for driving the tractor may be selected from any of the previously described prior art means such as the plurality of hydraulically actuated extendable wheels, spaced about the circumference of the tractor as illustrated in Figure 4, or the pair of hydraulically activated gripping mechanisms and telescopic cylinder used in the caterpillar-type tractor illustrated in Figures 5A-G, or any other equivalent structure. As indicated above, such means for driving a tractor are known in the art.

Unlike the prior art tractors, tractor 30 also includes a novel return fluid passageway 65. The return fluid passageway 65 is in fluid communication with the discharge of jet pump 25. Thus, the sand-laden slurry is pumped from jet pump 25 into the return fluid passageway 65 of tractor 30. The return fluid passageway may comprise one or more flow conduits. In one embodiment, the one or more flow conduits extend longitudinally through at least a portion of the wall of the tractor body, wherein the wall of the tractor body is defined as the area between the central passageway and the outer surface of the tractor body. Figure 7 illustrates one embodiment that includes four flow conduits 66 that extend longitudinally through wall 70. Flow conduits 66 are equally spaced around the tractor body and extend through the wall of the tractor body between the wheel wells for extendable wheels 72 and arms 75.

Alternatively, the one or more fluid flow conduits

may comprise one or more external flow channels 85 extending along at least a portion of the outer surface of the tractor body. Preferably, the one or more flow conduits extend substantially the entire length of the wellbore tractor so that the fluidized fill may be pumped by the jet pump through the tractor and exhausted or expelled behind the wellbore tractor. In a preferred embodiment, a fluid manifold 80 is in fluid communication between the one or more flow conduits and the discharge of jet pump 25. In one embodiment, one or more inlet ports 82 in manifold 80 receive the sand-laden slurry from jet pump 25.

Figure 8 illustrates an end view of one embodiment of a wellbore tractor having external flow channels. In the embodiment illustrated in Figure 8, four external flow channels 85 are spaced in between the retractable wheel assemblies. Wheels 72 are attached to the tractor body on retractable arms 75. The profile of the flow channels is less than the diameter of the extended wheel assemblies so that the flow channels will not become hung up on obstacles in the wellbore. By way of example, the tractor body may have an outer diameter of 3 1/8 inches (79 mm) and is run inside a wellbore having a diameter of 6 1/4 inches (160 mm) thus leaving approximately 1 1/2 inches (38 mm) of annular space between the body of the tractor and the wellbore. Each external flow channels may have, for example, a height of 1/2 inches (13 mm). Therefore, the tractor would have a tool diameter of 4 1/8 inches (105 mm) when the wheels are in the retracted position. As illustrated in Figure 8, fluid manifold 80 is in fluid communications with the discharge of the jet pump via inlet port 82 and distributes fluid to the external flow channels 85 such that the sand-laden slurry may be

pumped down the flow channels and exhausted or deposited behind the tractor. External flow channels 85 may be attached to the tractor body by any conventional means, such as bolts, set screws, straps or by welding. The
5 number and size of flow conduits 66 or external flow channels 85 are selected to maintain an effective flow area to handle the flow rate of the jet pump without creating significant back pressure.

For caterpillar-style tractors, such as the one
10 illustrated in Figures 3A-G, the return fluid passageway 65 may be arranged side-by-side with the central passageway 60 as shown in Figure 10. Alternatively, a divider may be attached by welding or other suitable means in the central passageway to partition a portion of
15 the passageway to create the return fluid passageway..

Figure 9 illustrates another embodiment of the invention for moving sand beds in front of the coiled tubing tractor to a location behind the tractor. The coiled tubing tractor assembly 100 comprises a forward
20 facing jetting assembly 120 connected to a coiled tubing tractor 130. Jetting assembly 120 includes one or more forward angled jet nozzles 122. The tractor includes a means for driving the tractor and pulling coiled tubing through the wellbore. Coiled tubing tractor assembly 100
25 does not include a jet pump. Instead, the coiled tubing tractor includes one or more rearward facing fluidizing jet nozzles 135. The rearward facing fluidizing nozzles extend through the body of tractor 130 and are in fluid communication with the central fluid passageway extending
30 through the tractor body. Although the wheeled tractor is illustrated in Figure 9, it will be appreciated that the invention may be used with a caterpillar-type tractor as well.

In operation, a power fluid is pumped down the coiled tubing to the coiled tubing tractor assembly. The power fluid powers the tractor so that the means for driving the tractor is activated. A portion of the power fluid continues through the central passageway of the tractor and exits the forward facing jetting assembly to stir and break up the sand beds in front of the tractor and fluidize the sand particles. At the same time, another portion of the power fluid will exit the one or more rearward facing fluidizing jet nozzles in the tractor body, the rearward facing fluidizing nozzles being a fluid communication with the central passageway of the tractor. The rearward facing nozzles maintain the sand particles in turbulent fluid suspension and move the sand back past the trailing end of the tractor, whereafter the sand will eventually form new sand beds up the wellbore. Like the jet pump method, the rearward facing fluidizing jetting method cleans the wellbore substantially of sand in the immediate vicinity of the tractor so the tractor may be driven in a substantially sand-free section of casing or wellbore.

By way of example, using the present invention may create a clean section of casing or wellbore, for instance, extending about three feet in front of and about three feet behind the tractor. Obviously, the length of the clean section of wellbore will be a function of many factors, such as flow rate, tractor size, hole size, jet sizes, and rheological properties of the power fluid.

Using the assembly illustrated in Figure 9 typically needs a higher fluid flow rate to suspend sand particles than an assembly having a jet pump, such as the one shown in Figure 1. This may require running the coiled tubing

tractor assembly on a bigger coiled tubing string. Thus, for example, when cleaning with a rearward facing jetting assembly flow rates of 1½ to 2 barrels per minute (238 to 318 litres per minute) in a 1¾ inch (44mm) to 2 inch
5 (51mm) coiled tubing may be required to adequately suspend and maintain the sand particles in suspension until they are deposited behind the tractor assembly. By way of comparison, using the coiled tubing tractor assembly with a jet pump may require a flow rate, for
10 example, on the order of 1 barrel per minute (159 litres per minute) through a 1½ inch (38mm) or 1¾ inch (44mm) coiled tubing string to adequately displace the sandbed.

Upon reaching the end of the wellbore or reaching a point where it is no longer possible to move the coiled
15 tubing string through the sand beds behind the tractor assembly, the sand is circulated out of the wellbore. There are several ways of removing the sand behind the tractor assembly out of the wellbore. The simplest method is to rely on pure fluid velocity and flow rates
20 to clean out the wellbore behind the tractor assembly. Typically, this method is practiced with the coiled tubing in a stationary position to keep from prematurely fatiguing the coiled tubing. Although simpler, this method may require several hole volumes to be circulated
25 at high fluid velocity to remove the sand from the wellbore and thus tends to be more time consuming and more expensive.

In a preferred embodiment, a pump through, in-line jetting tool 35 having rearward facing jet nozzles may be inserted between the coiled tubing and the coiled tubing tractor. The preferred jetting tool is described in U.S. Patent 6,607,607 (incorporated herein by reference), assigned to BJ Services Company, and available

commercially as the Tornado™ tool. The Tornado™ tool uses one or more rearward facing jet nozzles that may be selectively activated to re-entrain sand particles that have settled into beds 17 into the cleanout fluid.

5 Operationally, the power fluid is circulated down through the Tornado™ to the tractor and the forward facing jetting tool. The rearward facing nozzles of the Tornado™ are actuated by increasing the flow rate through the tool to a predetermined level. This causes an inner

10 mandrel inside the tool to shift, thereby closing off forward flow and directing flow through the rearward facing nozzles of the tool. The rearward nozzles may be larger than the forward facing nozzles so less pressure drop occurs through the rearward facing nozzles, thus

15 providing a surface indication that the rearward facing nozzles have been activated. By activating the rearward facing nozzles, circulating a cleanout fluid through the nozzles and controlling the pull-out-of-hole speed, the sand can be swept out of the hole with near 100%

20 efficiency. Smaller circulation volumes are required with the Tornado™ tool. The Tornado™ tool allows an operator to move the coiled tubing and to sweep the solids out of the wellbore at lower pressures and flow rates, thereby providing a more efficient clean up

25 process with less fatigue on the coiled tubing.

In another embodiment, larger nozzles may be included in the back of the tractor. By increasing the flow rate through the tractor, sand could be swept out of the hole while pulling the tractor out of the hole

30 without the use of a pump through, in-line jetting tool

35.

In an alternative embodiment of the invention, the coiled tubing tractor assembly requires much lower flow

rates through the tractor, thereby allowing the use of tractors with much smaller flow passageways. Although this assembly works well with concentric coiled tubing, it can also be effectively used with conventional coiled
5 tubing. This embodiment separates the fluidizing and suction functions from the pumping function of the jet pump.

When a jet pump is installed ahead of the tractor as illustrated in Figures 1 and 2, high pressure fluid is
10 pumped through the tractor and into the jet pump. In a typical well bore, flow rates of about 40 gallons per minute (151 litres per minute) may be used with the wellbore tractor assembly. The fluid is routed to the jet pump where, for example, about 25% of the fluid
15 (e.g., 10 gallons per minute (38 litres per minute)) is diverted on to the fluidizing jets to fluidize the well bore sands ahead of the tractor. The remainder of the fluid (e.g., about 30 gallons per minute (114 litres per minute)) goes through the jet pump nozzle, through the
20 throat and into the diffuser section of the jet pump and is converted back into pressure. The flow through the jet pump nozzle creates a venturi suction wherein the fluidized well bore sand is sucked back into the inlet port of the pump and combined with the power fluid. The
25 combined power fluid and well bore sand are then discharged into the annulus above the pump. In this arrangement, all of the fluid flow goes through the tractor to operate the jet pump and to pump the sand slurry behind the tractor. Some tractor geometries,
30 however, make it difficult to obtain reasonable flow rates through a conventional jet pump.

To accommodate such tractor geometries, a preferred embodiment of the present invention separates the jetting

nozzles and the suction inlet from the jet pump. By way of example, the fluidizing function and tractor driving means may require flowrates of about 10 gallons per minute (38 litres per minute) while the pumping function of a standard jet pump may require flowrates of about 30 gallons per minute (114 litres per minute). The fluidizing jets are placed at the front of the tractor in order to entrain the well bore solids (i.e., sand). The pump suction entrance is preferably located in front of (i.e., ahead of) the tractor so the solids fall-out is minimized. By placing the jet pump section behind the tractor, the need to pump all of the power fluid through the tractor is avoided.

In a preferred embodiment, two forward facing, angled jet nozzles are used to fluidize sand beds located in the wellbore ahead of the tractor assembly. The jet nozzles may be arranged on a rotating jetting head. One or more small fluid passageways may be used to provide the fluidizing flow through the tractor rather than one larger passageway as described in the prior embodiments. The flow passageways may be arranged side by side. Alternatively, the flow passageways may be arranged concentrically. By way of example a smaller diameter return flow conduit may be concentrically arranged inside a larger diameter conduit that provides the power fluid to drive the tractor and to fluidize wellbore sands with the jetting nozzles. A fluid manifold (not shown) may be used to deliver the fluidize sand from the suction inlet to the return flow conduit. The larger diameter conduit may be ported to deliver power fluid to the tractor driving mechanism. The choice of fluid passageway design will be dependent on specific tractor geometry and flow requirements, as well as how the tractor is powered.

Placing the tractor ahead of the jet pump is easier to manage because such an arrangement requires much lower flow rates, and thus smaller flow conduits, through the tractor.

5 The fluid power required to operate the tractor will preferably be channeled from the feed of the fluidizing flow stream so this flow conduit must be large enough to supply both the fluidizing and tractor power needs. This embodiment of the coiled tubing tractor assembly may be
10 used with either of the tractor types previously described.

 In this embodiment, the tractor is positioned between the fluidizing nozzles and the jet pump. The suction inlet is preferably located between the
15 fluidizing nozzles and the tractor. Thus, in the above example, only about 10 gallons per minute (38 litres per minute) of fluid is diverted through the jet pump, to the tractor and out the fluidizing nozzles. The remaining fluid (e.g., about 30 gallons per minute (114 litres per
20 minute)) is used to operate the jet pump, without having to pass through the tractor. In this embodiment, one or more fluid passageways are provided for diverting a portion of the power fluid from the jet pump, through the tractor to operate the tractor, and then out the
25 fluidizing nozzles. The fluidized well bore sand returns through the suction inlet and back through the tractor through one or more return flow conduits which are connected to, and therefore in fluid communication with, the inlet port of the jet pump.

30 Figure 11 illustrates the above-mentioned embodiment of the invention. A power fluid is delivered to the bottom hole assembly via the inner tubular 202 of a concentric coiled tubing string 200, for example, at a

flow rate of about 40 gallons per minute (151 litres per minute). About a quarter of the fluid that reaches jet pump 205 is split off and diverted to tractor 210. In this example, about 10 gallons per minute (38 litres per minute) flow into the tractor where a portion of the fluid is used to power the tractor. The remaining fluid continues through the one or more flow channels 215 until it reaches the fluidizing nozzles 220. The fluid exits the nozzles 220 to fluidize sand particles in the well bore, thereby creating a sand-laden slurry. The sand-laden slurry is then sucked into the suction inlets 225 and return to jet pump 205 via return flow conduit 230. The jet pump creates the suction force that draws the sand slurry into the suction inlets and provides the pressure to pump the slurry back to the surface via the annular space 203 between the inner and outer coils of the concentric coiled tubing string 200.

One of skill in the art will recognize that the present invention is not limited to the exemplary flow rates mentioned above. This embodiment of the invention allows well bore sands to be removed from ahead of the tractor and pumped out of the well bore to the surface without a separate wiper trip when used with a concentric coiled tubing string. The fluidized sand is pumped to the surface through the annulus between the inner and outer coiled tubings by the jet pump. To pump the sand slurry back to surface, more power and pressure is provided to the jet pump. This is achieved by selecting an appropriate flow rate and orifice size for the pump. In addition, there may be applications where it is desirable to supply the power fluid down the annulus between the inner and outer coiled tubings to the tractor assembly and pump the sand slurry to the surface via

inner tubular 202.

Alternatively, this embodiment may be used with a conventional coiled tubing string where the sands is removed from ahead of the tractor and deposited behind the tractor and ultimately removed as described in the 5 embodiments illustrated in Figures 2 and 9. Less power and pressure is needed at the jet pump when only displacing the sand behind the jet pump. A jet pump is generally regarded as a combination of a nozzle, throat 10 and diffuser whose purpose is to generate suction and then convert velocity (kinetic energy) back to pressure (potential energy) through the controlled deceleration of the fluid stream through a diffuser. The resulting pressure is necessary if the suction fluid has to be 15 pumped through any conduit where pressure losses would occur. In its simplest form, a jet pump might be configured with a suction nozzle and rudimentary throat if the primary purpose was only to suck and expel fluid. In the embodiment where the jet pump is located at the 20 rear of the tractor and where fluidized sand is being expelled into the well-bore behind the tractor, then very little jet pump pressure is actually required and thus a simple venturi nozzle and throat system could suffice. However, as used herein, the term "jet pump" shall 25 include both the conventional configuration as well as the simpler configuration having only a venturi nozzle and rudimentary throat.

An orifice (or a series orifices) and/or a pressure relief valve may be used to regulate flow between the 30 tractor and the jet nozzles, thereby balancing the flow requirements for fluidizing the sand and driving the tractor. The flow conduits through the tractor may be side by side (as illustrated in Figure 11) or may be

arranged concentrically. In the concentric arrangement, the outer tube is ported to divert a portion of the flow to the drive mechanism of the tractor. The concentric arrangement may be easier to use with current tractor
5 designs that typically have a conduit running through the center of the tractor. A smaller tube may be inserted inside the existing conduit. The outer conduit may also be enlarged if larger flow volumes are needed.

The return flow conduit(s) may also be arranged
10 about the external surface of the tractor (see e.g., Fig. 8) so long as the return flow conduit is in fluid communication with the suction inlet and the inlet port(s) of the jet pump. Alternatively, the return flow passageway(s) may be located in the wall of the tractor
15 body.

The coiled tubing tractor assembly illustrated in Fig. 11 may utilize one or more angled jet nozzles. The jet nozzles may be arranged on a rotating jetting head. When the tractor assembly is run on conventional coiled
20 tubing, the sand of the sand-laden slurry is deposited behind the tractor assembly by the jet pump. The deposited sand may be removed from the wellbore by employing wiper trips to circulate the sand to the surface. The sand may be swept out of the wellbore while
25 pulling out of the hole with the coiled tubing as described with the prior embodiments.

While the invention has been described in terms of preferred embodiments, it will be apparent to those of skill in the art that variations may be applied to the
30 process described herein without departing from the concept, spirit and scope of the invention. By way of example, the described apparatus and methods may also be used to remove particulate matter in flowlines. All such

similar substitutes and modifications apparent to those skilled in the art are deemed to be within the spirit, scope and concept of the invention as it is set out in the following claims.

5 A method for facilitating movement of a wellbore tractor along a pathway through an open wellbore or through a tubular lining a wellbore having particles such as sand, cuttings or fill material settled therein, the method comprising the steps of fluidizing the particles
10 in the pathway of the wellbore tractor and preferably, maintaining the particles in a fluidized state whilst the wellbore tractor moves through the fluidized particles. Advantageously, the particles settled in the pathway of the wellbore tractor are fluidized by fluid jetted into
15 the pathway of the wellbore tractor. Preferably, fluid flows through a passageway or conduit in or on the wellbore tractor and is jetted from the passageway or conduit into the pathway of the wellbore tractor. Preferably, the wellbore tractor has coiled tubing
20 connected to the rear of the wellbore tractor and the fluid for fluidizing the settled particles flows through the coiled tubing to in front of the wellbore tractor to fluidize the particles in the pathway of the wellbore tractor.

25 A wellbore tractor having a means for fluidizing settled particles lying in the pathway of the wellbore tractor. Preferably, the means comprises a fluid passageway or conduit with a fluid outlet to direct fluid into the pathway of the wellbore tractor to fluidize
30 settled particles lying in the pathway of the wellbore tractor. Preferably, the means or wellbore tractor comprises a return passageway to allow the fluidized particles to pass through or past the wellbore tractor

and to settle behind the wellbore tractor. Advantageously, the means comprises a fluid outlet directed in pathway already traversed by the wellbore tractor to maintain the particles fluidized. Preferably, 5 the wellbore tractor has a body and the fluid passageway and/or the return passageway are arranged in the body of the wellbore tractor.

CLAIMS

1. A wellbore tractor comprising:
 - a tractor body;
 - a central fluid passageway extending through the
 - 5 length of the tractor body;
 - one or more rearward facing jets extending through the tractor body and in fluid communication with the central fluid passageway; and
 - a means for driving the tractor through the
 - 10 wellbore.
2. The wellbore tractor of claim 1 further comprising a forward jetting assembly operable to fluidize sand beds ahead of the tractor body.
3. The wellbore tractor of claim 2 wherein the rearward
- 15 facing jets are operable to maintain the sand in fluid suspension until the sand travels past the tractor.
4. The wellbore tractor of claim 1 further comprising a rearward-jetting tool between the tractor body and a coiled tubing string.
- 20 5. The wellbore tractor of claim 1 further comprising a jet pump in fluid communication with the central fluid passageway.
6. The wellbore tractor of claim 1 further comprising at least one return flow conduit through the tractor
- 25 body.
7. A method of moving a coiled tubing tractor through a wellbore containing sand, the method comprising the steps of:
 - running a coiled tubing tractor assembly on a coiled
 - 30 tubing into the wellbore, the tractor assembly comprising one or more forward facing jet nozzles, the tractor and one or more rearward facing jet nozzles;
 - removing one or more sand beds ahead of the tractor

by fluidizing the sand particles with the one or more forward facing nozzles;

maintaining the sand in fluid suspension with the rearward facing nozzles until the sand particles settle
5 behind the tractor; and

driving the tractor through the portion of the wellbore that previously contained the one or more sand beds.

8. The method of claim 7 further comprising circulating
10 the sand out the wellbore.

9. The method of claim 7 further comprising sweeping the sand out of the wellbore while pulling out of the hole with the coiled tubing tractor assembly.

10. The method of claim 9 further comprising sweeping
15 sand out of the wellbore with a jetting tool located between the tractor and the coiled tubing, the jetting tool having one or more rearward facing jet nozzles.

11. The method of claim 7 further comprising circulating a portion of a power fluid through the tractor and out
20 the one or more forward facing jetting nozzles to create one or more jet streams in the wellbore ahead of the tractor assembly.

12. The method of claim 11 further comprising circulating another portion of the power fluid through
25 the one or more rearward facing jetting nozzles.

13. The method of claim 7 further comprising pumping at least a portion of the fluidized sand particles past the trailing end of the tractor with a jet pump.

14. The method of claim 7 further comprising pumping
30 fluid through at least one return flow conduit of the coiled tubing tractor assembly.

29

Application No: GB0708856.0

Examiner: Dr Michael Gooch

Claims searched: 1-14

Date of search: 30 May 2007

Patents Act 1977: Search Report under Section 17

Documents considered to be relevant:

Category	Relevant to claims	Identity of document and passage or figure of particular relevance
A	-	US6607607 B2 (BJ)
A	-	WO 03/067016 A2 (SUPERIOR)

Categories:

X	Document indicating lack of novelty or inventive step	A	Document indicating technological background and/or state of the art.
Y	Document indicating lack of inventive step if combined with one or more other documents of same category.	P	Document published on or after the declared priority date but before the filing date of this invention
&	Member of the same patent family	E	Patent document published on or after, but with priority date earlier than, the filing date of this application.

Field of Search:

Search of GB, EP, WO & US patent documents classified in the following areas of the UKC^X:

E1F; F2P

Worldwide search of patent documents classified in the following areas of the IPC

E21B

The following online and other databases have been used in the preparation of this search report

Online: EPODOC, WPI

International Classification:

Subclass	Subgroup	Valid From
E21B	0037/00	01/01/2006
E21B	0017/20	01/01/2006
E21B	0021/00	01/01/2006
E21B	0021/12	01/01/2006
E21B	0043/12	01/01/2006