

(19) World Intellectual Property Organization  
International Bureau



(43) International Publication Date  
25 October 2007 (25.10.2007)

PCT

(10) International Publication Number  
**WO 2007/118513 A1**

- (51) **International Patent Classification:**  
*H04B 15/04* (2006.01)
- (21) **International Application Number:**  
PCT/EP2006/067440
- (22) **International Filing Date:** 16 October 2006 (16.10.2006)
- (25) **Filing Language:** English
- (26) **Publication Language:** English
- (30) **Priority Data:**  
60/793,335            19 April 2006 (19.04.2006)    US  
11/544,121           6 October 2006 (06.10.2006)    US
- (71) **Applicant (for all designated States except US):** SONY ERICSSON MOBILE COMMUNICATIONS AB [SE/SE]; S-22188 Lund (SE).
- (72) **Inventor; and**
- (75) **Inventor/Applicant (for US only):** RUUSWIK, Anders [SE/SE]; Akeshögsvägen 11, S-3591 Vellinge (SE).
- (74) **Agent:** DAHNÉR, Christer; Valea AB, Box 7086, S-10387 Stockholm (SE).
- (81) **Designated States (unless otherwise indicated, for every kind of national protection available):** AE, AG, AL, AM,

AT, AU, AZ, BA, BB, BG, BR, BW, BY, BZ, CA, CH, CN, CO, CR, CU, CZ, DE, DK, DM, DZ, EC, EE, EG, ES, FI, GB, GD, GE, GH, GM, GT, HN, HR, HU, ID, IL, IN, IS, JP, KE, KG, KM, KN, KP, KR, KZ, LA, LC, LK, LR, LS, LT, LU, LV, LY, MA, MD, MG, MK, MN, MW, MX, MY, MZ, NA, NG, NI, NO, NZ, OM, PG, PH, PL, PT, RO, RS, RU, SC, SD, SE, SG, SK, SL, SM, SV, SY, TJ, TM, TN, TR, TT, TZ, UA, UG, US, UZ, VC, VN, ZA, ZM, ZW.

(84) **Designated States (unless otherwise indicated, for every kind of regional protection available):** ARIPO (BW, GH, GM, KE, LS, MW, MZ, NA, SD, SL, SZ, TZ, UG, ZM, ZW), Eurasian (AM, AZ, BY, KG, KZ, MD, RU, TJ, TM), European (AT, BE, BG, CH, CY, CZ, DE, DK, EE, ES, FI, FR, GB, GR, HU, IE, IS, IT, LT, LU, LV, MC, NL, PL, PT, RO, SE, SI, SK, TR), OAPI (BF, BJ, CF, CG, CI, CM, GA, GN, GQ, GW, ML, MR, NE, SN, TD, TG).

**Published:**  
— with international search report

For two-letter codes and other abbreviations, refer to the "Guidance Notes on Codes and Abbreviations" appearing at the beginning of each regular issue of the PCT Gazette.

(54) **Title:** SPECTRUM SPREADERS INCLUDING TUNABLE FILTERS AND RELATED DEVICES AND METHODS

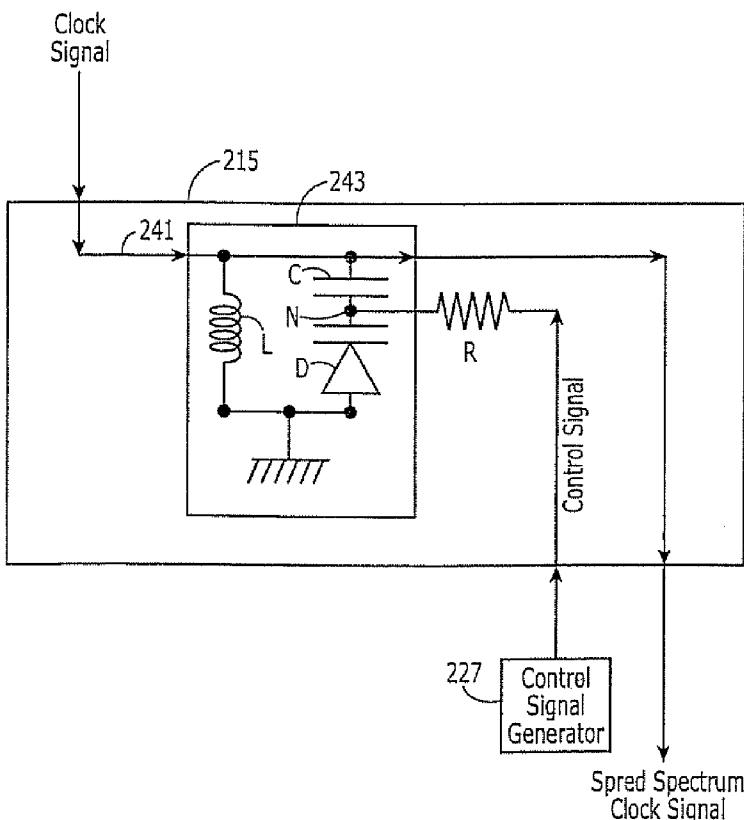

(57) **Abstract:** A spectrum spreader may include a signal conductor and a tunable filter. The signal conductor may be configured to receive a clock signal having a clock signal frequency. The tunable filter may be coupled to the signal conductor wherein the tunable filter is configured to spread a frequency of the clock signal responsive to a control signal to provide a spread spectrum clock signal. More particularly, a frequency of the spread spectrum clock signal may be spread relative to the clock frequency. Related communications devices and methods are also discussed.

WO 2007/118513 A1

## **SPECTRUM SPREADERS INCLUDING TUNABLE FILTERS AND RELATED DEVICES AND METHODS**

### **Related Application**

**[0001]** The present application claims the benefit of priority from U.S. Provisional Application No. 60/793,335 filed April 19, 2006, the disclosure of which is hereby incorporated herein in its entirety by reference.

### **Field Of The Invention**

**[0002]** The present invention relates to the field of electronics, and more particularly to spectrum spreaders for clock signals and related methods and devices.

### **Background**

**[0003]** In a radiotelephone, a reference crystal may be used to generate a clock signal for a processor of the radiotelephone. Harmonics of the clock signal, however, may interfere with the radio signals received at the radiotelephone. With a 13 MHz clock signal, for example, the 72<sup>nd</sup> and 73<sup>rd</sup> harmonics of the 13MHz clock signal may interfere with communications provided over one or more channels of the GSM (Global System For Mobile Telecommunications) 900MHz standard. For example, the 72<sup>nd</sup> harmonic at 936 MHz may interfere with GSM channel 5, and/or the 73<sup>rd</sup> harmonic may interfere with GSM channel 70. Because inputs/outputs to/from the radiotelephone processor are provided between the processor and other elements (*e.g.*, a keypad, a display, a speaker, a microphone, *etc.*) of the radiotelephone, it may be difficult to provide adequate shielding with respect to the clock signal and/or harmonics thereof.

### **Summary**

**[0004]** According to some embodiments of the present invention, a communications device may include a clock signal generator configured to generate a clock signal having a clock frequency, and a receiver configured to receive communications over an air interface. A spectrum spreader may be coupled to the clock signal generator, and the spectrum spreader may be configured to generate a

spread spectrum clock signal responsive to the clock signal wherein a frequency of the spread spectrum clock signal is spread relative to the clock frequency. In addition, a processor may be coupled to the receiver and to the spectrum spreader, and the processor may be configured to operate at the frequency of the spread spectrum clock signal and to process the communications received at the receiver. Moreover, the frequency of the spread spectrum clock signal may be spread above and below the clock frequency.

**[0005]** The spectrum spreader may include a signal conductor configured to receive a clock signal having a clock signal frequency, and a tunable filter coupled to the signal conductor. The tunable filter may be configured to spread a frequency of the clock signal responsive to a control signal to provide the spread spectrum clock signal. The tunable filter may include an inductor-capacitor (LC) band pass filter, for example, having an inductive circuit and a capacitive circuit coupled in parallel between the signal conductor and a reference voltage. In addition, the capacitive circuit may include a capacitor and a varactor diode coupled in series between the signal conductor and the reference voltage, and a control signal generator may be coupled to a control node between the capacitor and the varactor diode of the tunable filter such that the control signal generator is configured to generate the control signal that is applied to the control node. A resistor may also be coupled between the control signal generator and the control node.

**[0006]** More particularly, the control signal generator may be configured to generate the control signal having a control signal frequency such that the clock signal frequency is on the order of at least 10 times greater than the control signal frequency. The control signal generator, for example, may be configured to generate the control signal having a frequency in the range of about 1kHz to about 200kHz, and the clock signal frequency may be in the range of about 1MHz to about 100MHz. The control signal generator may be further configured to generate the control signal as a square wave, a triangular waver, and/or a sinusoidal wave, and/or to generate the control signal having a peak-to-peak amplitude of about 3 volts. In addition, the receiver may be coupled to the clock signal generator, and the receiver may be configured to receive communications over the air interface using the clock signal.

**[0007]** According to some other embodiments of the present invention, a spectrum spreader may include a signal conductor configured to receive a clock signal having a clock signal frequency, and a tunable filter coupled to the signal conductor.

The tunable filter may be configured to spread a frequency of the clock signal responsive to a control signal to provide a spread spectrum clock signal wherein a frequency of the spread spectrum clock signal is spread relative to the clock frequency. More particularly, the frequency of the spread spectrum clock signal may be spread above and below the clock frequency.

**[0008]** The tunable filter may include an inductor-capacitor (LC) band pass filter having an inductive circuit and a capacitive circuit coupled in parallel between the signal conductor and a reference voltage. The capacitive circuit may include a capacitor and a varactor diode coupled in series between the signal conductor and the reference voltage, and a control signal generator may be coupled to a control node between the capacitor and the varactor diode of the tunable filter with the control signal generator being configured to generate the control signal that is applied to the control node. In addition, a resistor may be coupled between the control signal generator and the control node.

**[0009]** The control signal generator may be further configured to generate the control signal having a control signal frequency such that the clock signal frequency is on the order of at least 10 times greater than the control signal frequency. For example, the control signal generator may be configured to generate the control signal having a frequency in the range of about 1kHz to about 200kHz, and the clock signal frequency may be in the range of about 1MHz to about 100MHz. Moreover, the control signal generator may be configured generate the control signal as a square wave, a triangular waver, and/or a sinusoidal wave, and/or having a peak-to-peak amplitude of about 3 volts.

**[0010]** According to still other embodiments of the present invention, a method of operating an electronic device may include receiving a clock signal having a clock signal frequency, and spreading a frequency of the clock signal responsive to a control signal to provide a spread spectrum clock signal. A frequency of the spread spectrum clock signal may be spread relative to the clock frequency. Moreover, the frequency of the spread spectrum clock signal may be spread above and below the clock frequency.

**[0011]** Receiving the clock signal may include receiving the clock signal on a signal conductor, and spreading the frequency of the clock signal may include filtering the clock signal using an inductor-capacitor (LC) band pass filter coupled to the signal conductor. More particularly, the inductor-capacitor (LC) band-pass filter

may include an inductive circuit and a capacitive circuit coupled in parallel between the signal conductor and a reference voltage. In addition, the capacitive circuit may include a capacitor and a varactor diode coupled in series between the signal conductor and the reference voltage, and the control signal may be applied to a control node between the capacitor and the varactor diode.

**[0012]** The clock signal frequency may be on the order of at least 10 times greater than a frequency of the control signal. For example, the control signal generator may be configured to generate the control signal having a frequency in the range of about 1kHz to about 200kHz, and the clock signal frequency may be in the range of about 1MHz to about 100MHz. Moreover, the control signal may be a square wave, a triangular wave, and/or a sinusoidal wave, and/or the control signal may have a peak-to-peak amplitude of about 3 volts.

**[0013]** In addition, communications may be received over an air interface, and the communications received over the air interface may be processed using the spread spectrum clock signal. Moreover, the communications may be received over the air interface using the clock signal without spreading.

### **Brief Description Of The Drawings**

**[0014]** Figure 1 is a block diagram of communications devices according to embodiments of the present invention.

**[0015]** Figure 2 is a schematic diagram of spectrum spreaders according to embodiments of the present invention.

### **Detailed Description**

**[0016]** Specific exemplary embodiments of the invention now will be described with reference to the accompanying drawings. This invention may, however, be embodied in many different forms and should not be construed as limited to the embodiments set forth herein. Rather, these embodiments are provided so that this disclosure will be thorough and complete, and will fully convey the scope of the invention to those skilled in the art. In the drawing, like numbers refer to like elements. It will be understood that when an element is referred to as being "connected" or "coupled" to another element, it can be directly connected or coupled to the other element or intervening elements may be present. Furthermore, "connected" or "coupled" as used herein may include wirelessly connected or coupled.

**[0017]** The terminology used herein is for the purpose of describing particular embodiments only and is not intended to be limiting of the invention. As used herein, the singular forms "a", "an" and "the" are intended to include the plural forms as well, unless expressly stated otherwise. It will be further understood that the terms "includes," "comprises," "including" and/or "comprising," when used in this specification, specify the presence of stated features, integers, steps, operations, elements, and/or components, but do not preclude the presence or addition of one or more other features, integers, steps, operations, elements, components, and/or groups thereof.

**[0018]** Unless otherwise defined, all terms (including technical and scientific terms) used herein have the same meaning as commonly understood by one of ordinary skill in the art to which this invention belongs. It will be further understood that terms, such as those defined in commonly used dictionaries, should be interpreted as having a meaning that is consistent with their meaning in the context of the relevant art and will not be interpreted in an idealized or overly formal sense unless expressly so defined herein.

**[0019]** It will be understood that although the terms first and second are used herein to describe various elements, these elements should not be limited by these terms. These terms are only used to distinguish one element from another element. Thus, a first frequency below could be termed a second frequency, and similarly, a second frequency may be termed a first frequency without departing from the teachings of the present invention. As used herein, the term "and/or" includes any and all combinations of one or more of the associated listed items. The symbol "/" is also used as a shorthand notation for "and/or".

**[0020]** Various embodiments of the present invention are described below with reference to block diagrams illustrating methods, apparatus and computer program products according to various embodiments of the invention. It will be understood that each block of the block diagrams and/or operational illustrations, and combinations of blocks in the block diagrams and/or operational illustrations, can be implemented by analog and/or digital hardware, and/or computer program instructions. These computer program instructions may be provided to a processor of a general purpose computer, special purpose computer, ASIC, and/or other programmable data processing apparatus, such that the instructions, which execute via the processor of the computer and/or other programmable data processing apparatus,

create means for implementing the functions/acts specified in the block diagrams and/or operational illustrations. Accordingly, it will be appreciated that the block diagrams and operational illustrations support apparatus, methods and computer program products.

**[0021]** Communications devices according to embodiments of the present invention are illustrated in Figure 1. As shown in Figure 1, a communications device **101** (such as a radiotelephone) may include a processor **103** (such as a central processing unit or CPU), a transceiver **105**, a user interface **109**, a fixed frequency clock signal generator **111** (such as an oscillator), and a spectrum spreader **115**. The transceiver **105** may include a transmitter **121** and a receiver **123** coupled to an antenna **125**. The user interface **109** may include a display **141**, a speaker **143**, a microphone **145**, and a keypad **147**. Moreover, the transceiver **105**, the oscillator **111**, and the spectrum spreader **115** may be provided in electromagnetic interference (EMI) shielding **117**.

**[0022]** Accordingly, the processor **103** and the transceiver **105** may operate to transmit and/or receive radio communications over an air interface using a system clock signal generated by the fixed frequency clock signal generator **111**. The system clock signal, for example, may be a sinusoidal wave having a frequency of about 13 MHz and a peak-to-peak amplitude of about 400mV, but other frequencies, amplitudes, and/or wave shapes may be used. For example, the system clock signal may have a frequency of about 26 MHz.

**[0023]** More particularly, the transmitter **121** may be configured to transmit communications generated by the processor **103** using one of a plurality of uplink frequency channels of an air interface, and the receiver **123** may be configured to receive communications using one of a plurality of downlink frequency channels of the air interface. By way of example, the GSM 900 MHz air interface standard may provide a plurality of 200 kHz wide uplink frequency channels (for transmissions from a mobile terminal to a base station) over an uplink frequency band in the range of about 933 MHz to about 960 MHz and a plurality of 200 kHz wide downlink frequency channels (for transmissions from a base station to a mobile terminal) over an downlink frequency band in the range of about 890 MHz to about 915 MHz. In alternatives, the transceiver **105** may be configured to operate using other air interface standards such as the PCS (Personal Communications Services) standard and/or DCS

(Digital Cellular System) standard, and/or using other frequency bands such as frequency bands at about 900 MHz, 1800 MHz, and/or 1900 MHz.

[0024] The clock signal generator **111** may thus generate a clock signal having a fixed clock frequency, and the transmitter **105** and the receiver **123** of the transceiver **121** may operate using the clock signal having the fixed frequency of, for example, 13 MHz. Harmonic components of the clock signal may interfere with frequencies used for communications channels received using receiver **123**, and the EMI shielding **117** may reduce this potential interference. Proper operation of the transmitter **121** and/or the receiver **123** may require that the clock signal received from the clock signal generator **111** at the transceiver **105** have a relatively fixed frequency.

[0025] Operations of the processor **103**, however, may not require as precise a clock frequency as may be required by the transceiver **105**. Accordingly, the processor **103** may run using the spread spectrum clock signal that is derived from the clock signal using the spectrum spreader **115**. More particularly, the spectrum spreader **115** may be configured to generate a spread spectrum clock signal responsive to the clock signal from the clock signal generator **111** wherein a frequency of the spread spectrum clock signal is spread relative to the clock frequency. More particularly, the frequency of the spread spectrum clock signal may be spread above and below the clock frequency. By spreading the frequency of the clock signal provided to the processor **103**, harmonic components of the spread spectrum clock signal may be spread over different frequencies so that an aggregate of interference at particular channel frequencies may be reduced. Accordingly, EMI shielding for the processor **103** and/or other components (such as the user interface **109**) in communication with the processor **103** may be reduced and/or eliminated.

[0026] Accordingly, the communications device **101** may include the clock signal generator **111** configured to generate the clock signal having the clock frequency, and the receiver **123** coupled to the clock signal generator. Accordingly, the receiver **123** may be configured to receive communications over an air interface using the clock signal. The spectrum spreader **115** is also coupled to the clock signal generator **111**, and the spectrum spreader **115** may be configured to generate a spread spectrum clock signal responsive to the clock signal wherein a frequency of the spread spectrum clock signal is spread relative to the clock frequency. More particularly, the processor **103** may be coupled to the receiver **123** and to the spectrum spreader **115**,

and the processor **103** may be configured to operate at the frequency of the spread spectrum clock signal and to process the communications received at the receiver.

**[0027]** According to some embodiments of the present invention, the spectrum spreader **115** may include a signal conductor and a tunable filter coupled to the signal conductor. The signal conductor may be configured to receive a clock signal having a clock signal frequency, and the tunable filter may be configured to spread a frequency of the clock signal responsive to a control signal to provide a spread spectrum clock signal. More particularly, the tunable filter may be an inductor-capacitor (LC) band pass filter having an inductive circuit and a capacitive circuit coupled in parallel between the signal conductor and a reference voltage. Moreover, the capacitive circuit may include a capacitor and a varactor diode coupled in series between the signal conductor and the reference voltage.

**[0028]** As further shown in Figure 1, the control signal may be generated by a control signal generator **127**, and the control signal may be applied to a control node between the capacitor and the varactor diode of the tunable filter included of the spectrum spreader **115**. While the control signal generator **127** is shown in Figure 1 as an element of the processor **103**, the control signal generator **127** may be implemented in whole or in part outside the processor **103**. The control signal generator **127** may be configured to generate the control signal such that the clock signal frequency is on the order of at least 10 times greater than a frequency of the control signal. More particularly, a frequency of the control signal may be in the range of about 1kHz to about 200kHz, and the clock signal frequency may be in the range of about 1MHz to about 100MHz. Moreover, the control signal generator **127** may generate the control signal as a square wave, a triangular waver, and/or a sinusoidal wave, and/or the control signal may have a peak-to-peak amplitude of about 3 volts. For example, the control signal may oscillate between about 0 Volts and about 2.9 Volts. While particular frequencies, wave shapes, and amplitudes of the control signal have been discussed by way of example, the control signal may be provided using other frequencies, wave shapes, and/or amplitudes according to embodiments of the present invention. In addition, a resistor may be coupled between the control signal generator **127** and the control node of the tunable filter.

**[0029]** The spectrum spreader **115** may thus generate the spread spectrum clock signal responsive to the clock signal generated by the clock signal generator **111** and responsive to the control signal generated by the control signal generator **127**. By

way of example, the clock signal (generated by the clock signal generator **111**) may have a frequency of about 13 MHz, and the control signal (generated by the control signal generator **127**) may have a frequency in the range of about 1kHz to about 200kHz, more particularly, in the range of about 30 kHz to about 100 kHz, and still more particularly, in the range of about 90kHz to about 100kHz. According to other embodiments of the present invention, the clock signal may have a frequency of about 26 MHz, and the control signal may have a frequency in the range of about 1 kHz to about 200 kHz.

**[0030]** More particularly, the control signal generator **127** may be configured to adapt one or more characteristics of the control signal, for example, to accommodate changes in operating conditions. A feed-back loop from the receiver **123** to the processor **103** and/or the control signal generator **127** may allow a determination of interference with communications received through the receiver **123**, and the control signal generator **127** may be configured to adapt one or more characteristics of the control signal responsive to changes in levels of interference at the receiver **123**. According to some embodiments of the present invention, the control signal generator **127** may generate the control signal having a first non-zero frequency during a first period of time and a second non-zero frequency during a second period of time, wherein the first and second frequencies are different. Moreover, during a third period of time, the control signal generator may be configured to generate a control signal having a frequency of zero, so that the phase of the clock signal is not shifted and the spectrum of the clock is not spread during the third period of time.

**[0031]** According to some other embodiments of the present invention, the control signal generator **127** may be configured to generate the control signal having a first wave shape (such as one of a square wave, a sinusoidal wave, and a triangular wave) during a first period of time, and having another wave shape (such as another of a square wave, a sinusoidal wave, and a triangular wave) during a second period of time, wherein the first and second wave shapes are different. According to still other embodiments of the present invention, the control signal generator **127** may be configured to generate the control signal having a first non-zero amplitude during a first period of time and having a second non-zero amplitude during a second period of time, wherein the first and second non-zero amplitudes are different.

[0032] As shown in Figure 1, the clock signal from the clock signal generator **111** may be provided to both the transceiver **105** and to the spectrum spreader **115** (used to provide the spread spectrum clock signal for the processor **103**). Accordingly, one clock signal generator **111** (such as one oscillator) may be used to reduce cost and/or space. In an alternative, separate clock signal generators (such as separate oscillators) may be used to provide separate clock signals to the spectrum spreader **115** and to the transceiver **105**.

[0033] While not shown in Figure 1, an impedance (such as a resistance or resistor) may be provided to isolate the spectrum spreader **115** from the clock signal generator **111** and/or from the transceiver **105**. For example, an impedance (such as a resistor) may be provided in the spectrum spreader **115** and/or along the signal line between the clock signal generator **111** and the spectrum spreader **115** (after split to the transceiver **105**), and/or the signal line between the clock signal generator **111** and the spectrum spreader **115** may provide sufficient impedance without requiring a separate impedance element. If a separate clock signal generator is provided for the transceiver **105** so that the clock signal generator **111** is not coupled to the transceiver **105**, an impedance (such as a resistor) may be provided in the clock signal generator **111**, in the spectrum spreader **115**, and/or along the signal line anywhere between the clock signal generator **111** and the spectrum spreader **115**, and/or the signal line between the clock signal generator **111** and the spectrum spreader **115** and/or an output impedance of the clock signal generator **111** may provide sufficient impedance without requiring a separate impedance element.

[0034] A spectrum spreader **215** according to particular embodiments of the present invention is shown in Figure 2. More particularly, the spectrum spreader **215** may include a signal conductor **241** configured to receive a clock signal having a clock signal frequency, and a tunable filter **243** coupled to the signal conductor **241**. The tunable filter **243** may be configured to spread a frequency of the clock signal responsive to a control signal generated by the control signal generator **227** to provide a spread spectrum clock signal wherein a frequency of the spread spectrum clock signal is spread relative to the clock frequency. More particularly, the frequency of the spread spectrum clock signal may be spread above and below the clock frequency.

[0035] As shown in Figure 2, the tunable filter **243** may be an inductor-capacitor (LC) band pass filter including an inductive circuit and a capacitive circuit coupled in parallel between the signal conductor and a reference voltage (such as a

ground voltage). The inductive circuit may include inductor **L**, and the capacitive circuit may include a capacitor **C** and a varactor diode **D** coupled in series between the signal conductor **241** and the reference voltage (such as ground). Moreover, the control signal generator **227** may be coupled to a control node **N** between the capacitor **C** and the varactor diode **D** of the tunable filter **243** wherein the control signal generator **227** is configured to generate the control signal that is applied to the control node **N**. In addition, an impedance (such as a resistor **R**) may be coupled in series between the control signal generator **227** and the control node **N**.

**[0036]** The control signal generator **227** may be configured to generate the control signal having a control signal frequency such that the clock signal frequency is on the order of at least 10 times greater than the control signal frequency. For example, the control signal may have a frequency in the range of about 1kHz to about 200kHz and the clock signal may have a frequency in the range of about 1MHz to about 100MHz. More particularly, the clock signal may have a frequency of about 13MHz, and the control signal may have a frequency in the range of about 30 kHz to about 100 kHz, and more particularly, in the range of about 90kHz to about 100kHz. Moreover, the control signal generator **227** may be configured to generate the control signal as a square wave, a triangular wave, and/or a sinusoidal wave, and/or having a peak-to-peak amplitude of about 3 volts. As discussed above, the clock signal and/or the control signal may be provided with other frequencies and/or wave shapes. For example, the clock signal may have a frequency of about 26 MHz and the control signal may have a frequency in the range of about 1 kHz to about 200 kHz.

**[0037]** The components of the tunable filter **243** may thus be provided so that the tunable filter **243** provides a band pass filter characteristic with a resonance of the filter (or center frequency of the pass band) being about the same as the frequency of the clock signal. By providing the control signal at the control node **N** between the capacitor **C** and the varactor diode **D**, an effective capacitance provided by the combination of the capacitor **C** and the varactor diode **D** may vary with the control signal. In other words, an effective capacitance of the varactor diode **D** may be varied by varying a back voltage of the varactor diode **D** using the control signal. Accordingly, a resonance of the tunable filter **243** may be varied with the control signal so that a phase of the spread spectrum clock signal alternately leads and lags a phase of the clock signal responsive to the control signal. For example, the phase of the spread spectrum clock signal may alternately lead and lag the phase of the clock

signal by about +/- 5 degrees or less. A frequency of the spread spectrum clock signal may thus vary above and below a frequency of the clock signal as the phase of the spread spectrum clock signal varies between leading and lagging the phase of the clock signal. Harmonics of the spread spectrum clock signal may be similarly spread so that interference at particular communications channels may be reduced.

**[0038]** The spectrum spreader **215** may also provide resiliency in the event of failure. If the control signal generator **227** and/or the tunable filter malfunction, for example, a frequency of the spread spectrum clock signal may no longer vary relative to that of the clock signal and harmonics of the spread spectrum clock signal may be concentrated at particular communications channels. A communications device incorporating the spectrum spreader **215** of Figure 2 may thus continue operations, for example, without using the communications channel(s) most effected by the harmonics of the spread spectrum clock signal, or the affected channels may be used with decreased sensitivity.

**[0039]** According to some embodiments of the present invention, the spectrum spreader **115** of Figure 1 may be implemented as the spectrum spreader **215** of Figure 2 with the control signal generator **127** of Figure 1 being implemented as the control signal generator **227** of Figure 2. Accordingly, the clock signal of Figure 2 may be provided by the clock signal generator **111** of Figure 1, the control signal generator **227** of Figure 2 may be implemented within the processor **103** of Figure 1, and the spread spectrum clock signal of Figure 2 may be provided to the processor **103** of Figure 1. While the control signal generator **227** is discussed above as being implemented in a processor of a communications device, the control signal generator **227** (and/or portions thereof) may be implemented as a portion of the spectrum spreader **215**, and/or outside the spectrum spreader and processor.

**[0040]** In addition, an impedance (such as a resistance or resistor) may be provided to isolate the spectrum spreader **215** from the clock signal and/or from a transceiver also coupled to the clock signal. For example, an impedance (such as a resistor) may be provided between the clock signal and the tunable filter **243**, for example, along the signal conductor **241** in the spectrum spreader **115** and/or along the signal line between the clock signal and the spectrum spreader **215** (after any split to a transceiver), and/or the signal line(s) between the clock signal and the tunable filter **243** may provide sufficient impedance without requiring a separate impedance element. If a separate clock signal generator is provided for any transceiver so that

the clock signal of Figure 2 is not coupled to a transceiver, an impedance (such as a resistor) may be provided in the clock signal generator generating the clock signal of Figure 2, in the spectrum spreader **215**, and/or along the signal line anywhere between the clock signal generator and the spectrum spreader **215**; and/or the signal line between the clock signal generator and the spectrum spreader **215** and/or an output impedance of the clock signal generator **111** may provide sufficient impedance without requiring a separate impedance element.

**[0041]** Based on simulations of a core voltage of a processor of a radiotelephone with and without a spectrum spreader according to embodiments of the present invention, a reduction of about 5 dBm of interference may be provided at 936 MHz (*i.e.*, receive channel No. 5 according to the GSM 900 MHz standard) with a clock signal of 13 MHz. More particularly, in a GSM radiotelephone including a spectrum spreader **215** as illustrated in Figure 2 according to embodiments of the present invention, simulated noise from harmonics of a 13 MHz clock signal at 936 MHz was about -128 dBm. In the same GSM radiotelephone without the spectrum spreader, simulated noise from harmonics of a 13 MHz clock signal at 936 MHz was about -123 dBm. Moreover, the spectrum spreader **215** may consume relatively little power, may operate with little or no start-up time, and/or may be implemented with relatively few additional parts.

**[0042]** While the spectrum spreader **115** of Figure 1 is discussed above as being implemented with the spectrum spreader **215** of Figure 2 according to some embodiments of the present invention, the communications device **101** of Figure 1 may be implemented with other spectrum spreaders according to embodiments of the present invention. Other spectrum spreaders are discussed, for example, in U.S. Patent Pub. No. 2002/0131541, U.S. Patent Pub. No. 2003/0160641, U.S. Patent Pub. No. 2005/0030114, U.S. Patent Pub. No. 2004/0257124, and U.S. Patent Pub. No. 2005/0180490, the disclosures of which are hereby incorporated herein in their entirety by reference. Still other spectrum spreaders are discussed in the specification from Alliance Semiconductor entitled "*Low Power Peak EMI Reducing Solution*" ASM3P2872A, Ref. 2.03, August 2004, the disclosure of which is hereby incorporated herein in its entirety by reference. With other spectrum spreaders, the control signal generator and/or the control signal of Figure 1 may not be required.

**[0043]** In the drawings and specification, there have been disclosed embodiments of the invention and, although specific terms are employed, they are

used in a generic and descriptive sense only and not for purposes of limitation, the scope of the invention being set forth in the following claims.

**That Which Is Claimed Is:**

1. A communications device comprising:
  - a clock signal generator configured to generate a clock signal having a clock frequency;
  - a receiver coupled to the clock signal generator wherein the receiver is configured to receive communications over an air interface using the clock signal;
  - a spectrum spreader coupled to the clock signal generator wherein the spectrum spreader is configured to generate a spread spectrum clock signal responsive to the clock signal wherein a frequency of the spread spectrum clock signal is spread relative to the clock frequency; and
  - a processor coupled to the receiver and to the spectrum spreader wherein the processor is configured to operate at the frequency of the spread spectrum clock signal and to process the communications received at the receiver.
  
2. A communications device according to Claim 1 wherein the receiver is coupled to the clock signal generator and wherein the receiver is configured to receive communications over the air interface using the clock signal.
  
3. A communications device according to Claim 1 or 2 wherein the spectrum spreader comprises,
  - a signal conductor configured to receive a clock signal having a clock signal frequency, and
  - a tunable filter coupled to the signal conductor wherein the tunable filter is configured to spread a frequency of the clock signal responsive to a control signal to provide the spread spectrum clock signal.
  
4. A communications device according to Claim 3 wherein the tunable filter comprises an inductor-capacitor (LC) band pass filter.
  
5. A communications device according to Claim 3 wherein the tunable filter comprises an inductive circuit and a capacitive circuit coupled in parallel between the signal conductor and a reference voltage.

6. A communications device according to Claim 5 wherein the capacitive circuit comprises a capacitor and a varactor diode coupled in series between the signal conductor and the reference voltage.

7. A communications device according to Claim 6 further comprising:  
a control signal generator coupled to a control node between the capacitor and the varactor diode of the tunable filter wherein the control signal generator is configured to generate the control signal that is applied to the control node.

8. A communications device according to Claim 7 wherein the control signal generator is further configured to generate the control signal having a control signal frequency such that the clock signal frequency is on the order of at least 10 times greater than the control signal frequency.

9. A spectrum spreader comprising:  
a signal conductor configured to receive a clock signal having a clock signal frequency; and  
a tunable filter coupled to the signal conductor wherein the tunable filter is configured to spread a frequency of the clock signal responsive to a control signal to provide a spread spectrum clock signal wherein a frequency of the spread spectrum clock signal is spread relative to the clock frequency.

10. A spectrum spreader according to Claim 9 wherein the tunable filter comprises an inductor-capacitor (LC) band pass filter.

11. A spectrum spreader according to Claim 9 wherein the tunable filter comprises an inductive circuit and a capacitive circuit coupled in parallel between the signal conductor and a reference voltage.

12. A spectrum spreader according to Claim 11 wherein the capacitive circuit comprises a capacitor and a varactor diode coupled in series between the signal conductor and the reference voltage.

13. A spectrum spreader according to Claim 12 further comprising:

a control signal generator coupled to a control node between the capacitor and the varactor diode of the tunable filter wherein the control signal generator is configured to generate the control signal that is applied to the control node.

14. A spectrum spreader according to Claim 13 wherein the control signal generator is further configured to generate the control signal having a control signal frequency such that the clock signal frequency is on the order of at least 10 times greater than the control signal frequency.

15. A method of operating an electronic device, the method comprising:  
receiving a clock signal having a clock signal frequency; and  
spreading a frequency of the clock signal responsive to a control signal to provide a spread spectrum clock signal wherein a frequency of the spread spectrum clock signal is spread relative to the clock frequency.

16. A method according to Claim 15 wherein receiving the clock signal comprises receiving the clock signal on a signal conductor and wherein spreading the frequency of the clock signal comprises filtering the clock signal using an inductor-capacitor (LC) band pass filter coupled to the signal conductor.

17. A method according to Claim 16 wherein the inductor-capacitor (LC) band-pass filter comprises an inductive circuit and a capacitive circuit coupled in parallel between the signal conductor and a reference voltage.

18. A method according to Claim 17 wherein the capacitive circuit comprises a capacitor and a varactor diode coupled in series between the signal conductor and the reference voltage.

19. A method according to Claim 18 wherein the control signal is applied to a control node between the capacitor and the varactor diode.

20. A method according to Claim 19 wherein the clock signal frequency is on the order of at least 10 times greater than a frequency of the control signal.

21. A method according to any of Claims 15 - 20 further comprising:  
receiving communications over an air interface; and  
processing the communications received over the air interface using the spread spectrum clock signal.

22. A method according to Claim 21 wherein receiving communications over the air interface comprises receiving communications over the air interface using the clock signal without spreading.

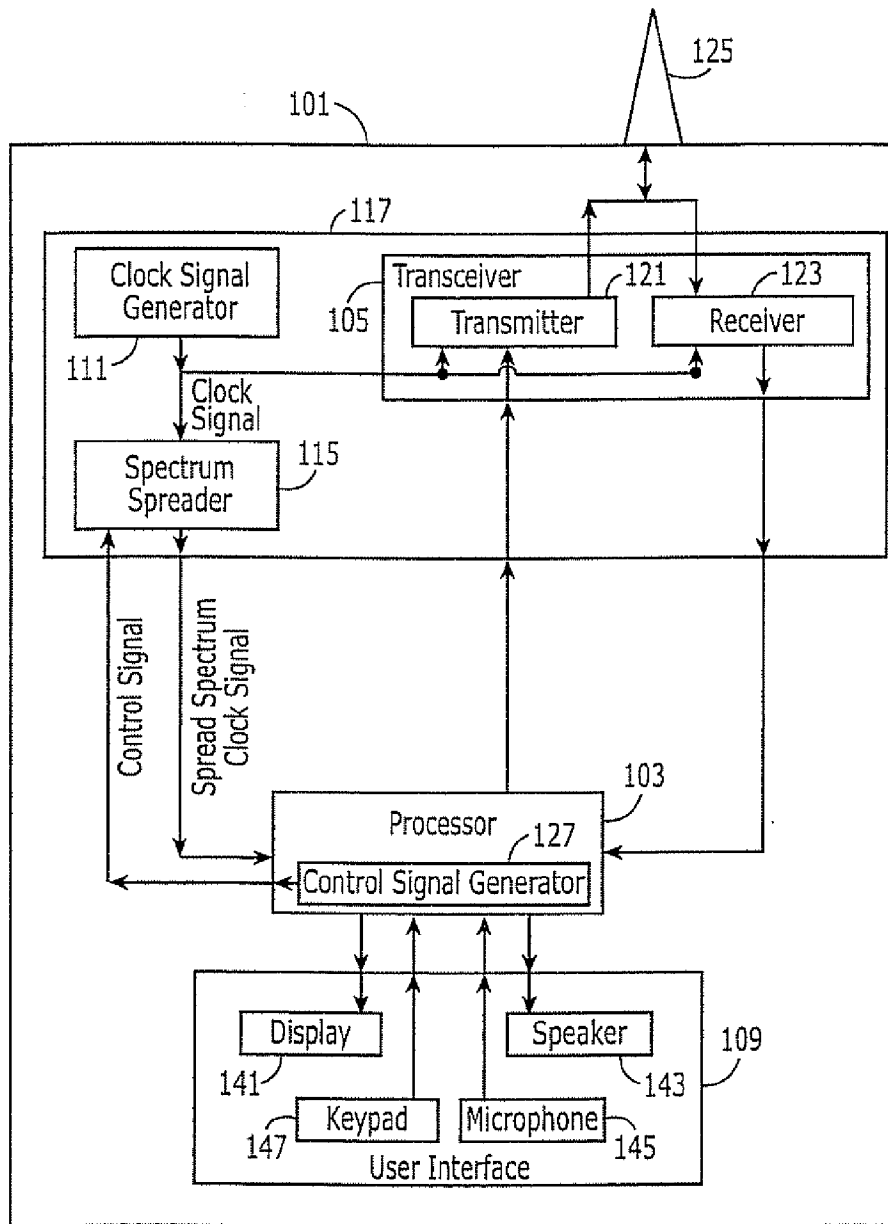

Figure 1

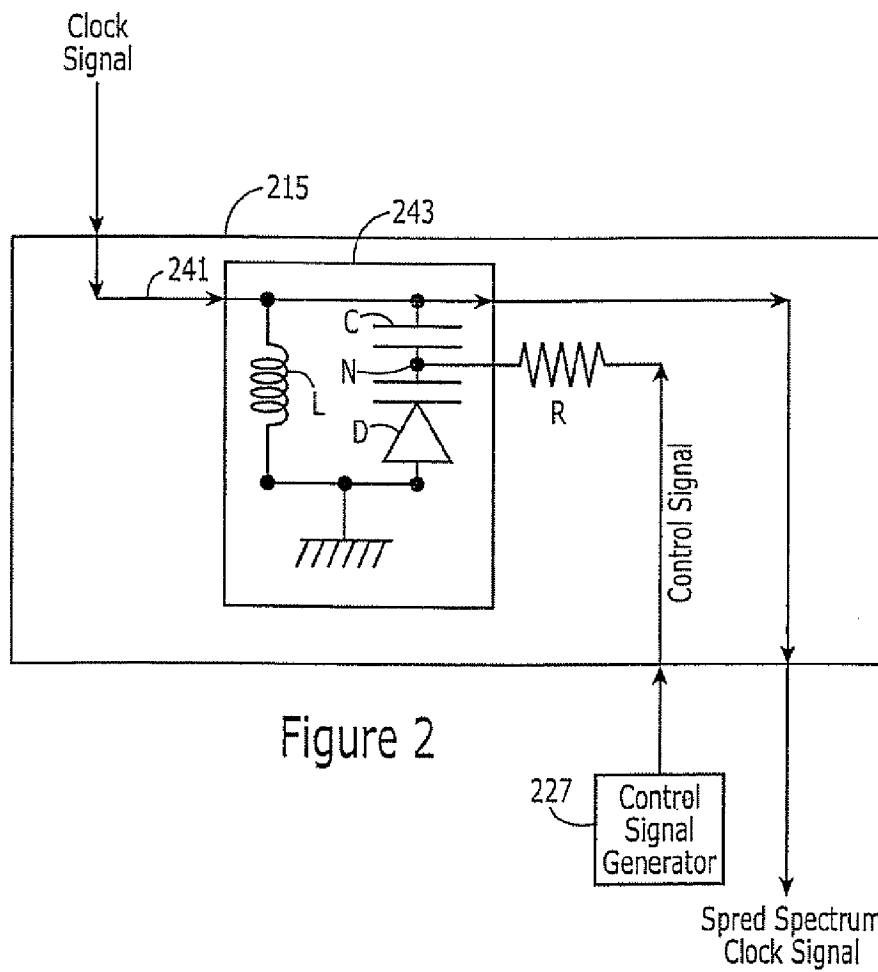

Figure 2

INTERNATIONAL SEARCH REPORT

International application No  
PCT/EP2006/067440

A. CLASSIFICATION OF SUBJECT MATTER  
INV. H04B15/04

According to International Patent Classification (IPC) or to both national classification and IPC

B. FIELDS SEARCHED

Minimum documentation searched (classification system followed by classification symbols)  
H04B

Documentation searched other than minimum documentation to the extent that such documents are included in the fields searched

Electronic data base consulted during the international search (name of data base and, where practical, search terms used)  
EPO-Internal, WPI Data

C. DOCUMENTS CONSIDERED TO BE RELEVANT

Category*	Citation of document, with indication, where appropriate, of the relevant passages	Relevant to claim No.
X	EP 0 416 423 A2 (TELENOKIA OY [FI] NOKIA TELECOMMUNICATIONS OY [FI]) 13 March 1991 (1991-03-13) column 4, line 19 - column 5, line 6; figures 2,3	1-3,9, 15,21,22
X	GB 2 350 988 A (MOTOROLA INC [US]) 13 December 2000 (2000-12-13) abstract; figures 1,3,4 page 9, line 10 - line 15	1,2,14, 15,20-22
A	US 5 263 055 A (CAHILL STEPHEN V [US]) 16 November 1993 (1993-11-16) abstract; figure 1	1-22
A	US 6 169 889 B1 (SERVILIO MARK L [US] ET AL) 2 January 2001 (2001-01-02) abstract; figures 1,3,20	1-22
	-/--	

Further documents are listed in the continuation of Box C.  See patent family annex.

\* Special categories of cited documents :

\*A\* document defining the general state of the art which is not considered to be of particular relevance

\*E\* earlier document but published on or after the international filing date

\*L\* document which may throw doubts on priority claim(s) or which is cited to establish the publication date of another citation or other special reason (as specified)

\*O\* document referring to an oral disclosure, use, exhibition or other means

\*P\* document published prior to the international filing date but later than the priority date claimed

\*T\* later document published after the international filing date or priority date and not in conflict with the application but cited to understand the principle or theory underlying the invention

\*X\* document of particular relevance; the claimed invention cannot be considered novel or cannot be considered to involve an inventive step when the document is taken alone

\*Y\* document of particular relevance; the claimed invention cannot be considered to involve an inventive step when the document is combined with one or more other such documents, such combination being obvious to a person skilled in the art.

\* & \* document member of the same patent family

Date of the actual completion of the international search  12 January 2007	Date of mailing of the international search report  25/01/2007
--	--

Name and mailing address of the ISA European Patent Office, P.B. 5818 Patentlaan 2 NL - 2280 HV Rijswijk Tel. (+31-70) 340-2040, Tx. 31 651 epo nl, Fax: (+31-70) 340-3016	Authorized officer  Kolbe, Werner
--	---

## INTERNATIONAL SEARCH REPORT

International application No  
PCT/EP2006/067440

C(Continuation). DOCUMENTS CONSIDERED TO BE RELEVANT

Category*	Citation of document, with indication, where appropriate, of the relevant passages	Relevant to claim No.
A	EP 0 655 829 A1 (LEXMARK INT INC [US]) 31 May 1995 (1995-05-31) abstract; figures 1,8 -----	1-22
A	US 6 501 307 B1 (YEN YAO TUNG [US]) 31 December 2002 (2002-12-31) abstract; figure 7 -----	1,9,15

# INTERNATIONAL SEARCH REPORT

Information on patent family members

International application No PCT/EP2006/067440
---

Patent document cited in search report	Publication date	Patent family member(s)	Publication date
EP 0416423	A2	13-03-1991	DE 69023191 D1 30-11-1995
			DE 69023191 T2 04-04-1996
			FI 83143 B 15-02-1991
GB 2350988	A	13-12-2000	NONE
US 5263055	A	16-11-1993	CA 2081004 A1 05-05-1993
US 6169889	B1	02-01-2001	NONE
EP 0655829	A1	31-05-1995	AU 676355 B2 06-03-1997
			AU 7282194 A 15-06-1995
			CA 2131567 A1 30-05-1995
			DE 69427114 D1 23-05-2001
			DE 69427114 T2 18-10-2001
			JP 7235862 A 05-09-1995
			JP 2006217642 A 17-08-2006
			US 5488627 A 30-01-1996
			US 5631920 A 20-05-1997
US 6501307	B1	31-12-2002	NONE