

[72] Inventor **James M. Denker**
 Scituate, Mass.
 [21] Appl. No. **834,737**
 [22] Filed **June 19, 1969**
 [45] Patented **June 28, 1971**
 [73] Assignee **Nutron Corporation**
 Hingham, Mass.

[56] **References Cited**
UNITED STATES PATENTS
 3,349,800 10/1967 Herion et al. 137/625.48X
 3,452,780 7/1969 Faustini..... 251/141X
Primary Examiner—William F. O'Dea
Assistant Examiner—Robert J. Miller
Attorney—William W. Rymer

[54] **VALVING**
 14 Claims, 2 Drawing Figs.
 [52] U.S. Cl. 137/625.65,
 137/625.48, 251/137
 [51] Int. Cl. F16k 11/00
 [50] Field of Search 137/625.65,
 625.64, 625.2, 625.48; 251/137, 139, 129

ABSTRACT: A magnetic valve comprising a housing defining a valving surface and an inlet passage terminating at the surface in an inlet port, a valving member at least in part of magnetic material having a cavity extending inwardly from an opening in a surface thereof mounted on the housing with the surface thereof engaging the valving surface, an electromagnet for moving the valving member relative to the housing, and means for constraining movement of the valving member relative to the housing so that at least a portion of the inlet port is invariably within the bounds of the opening.

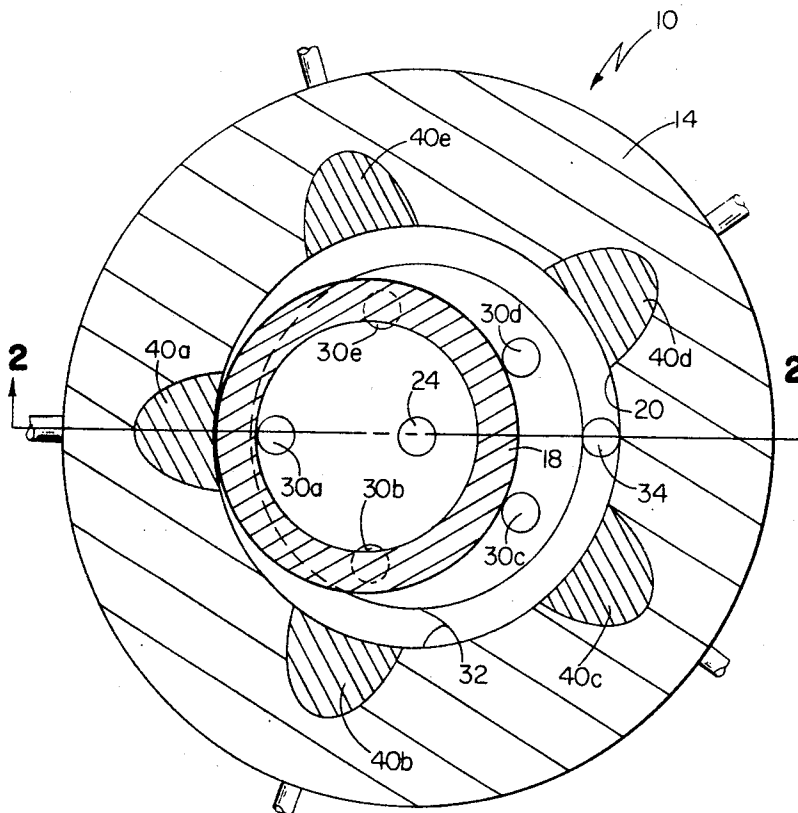

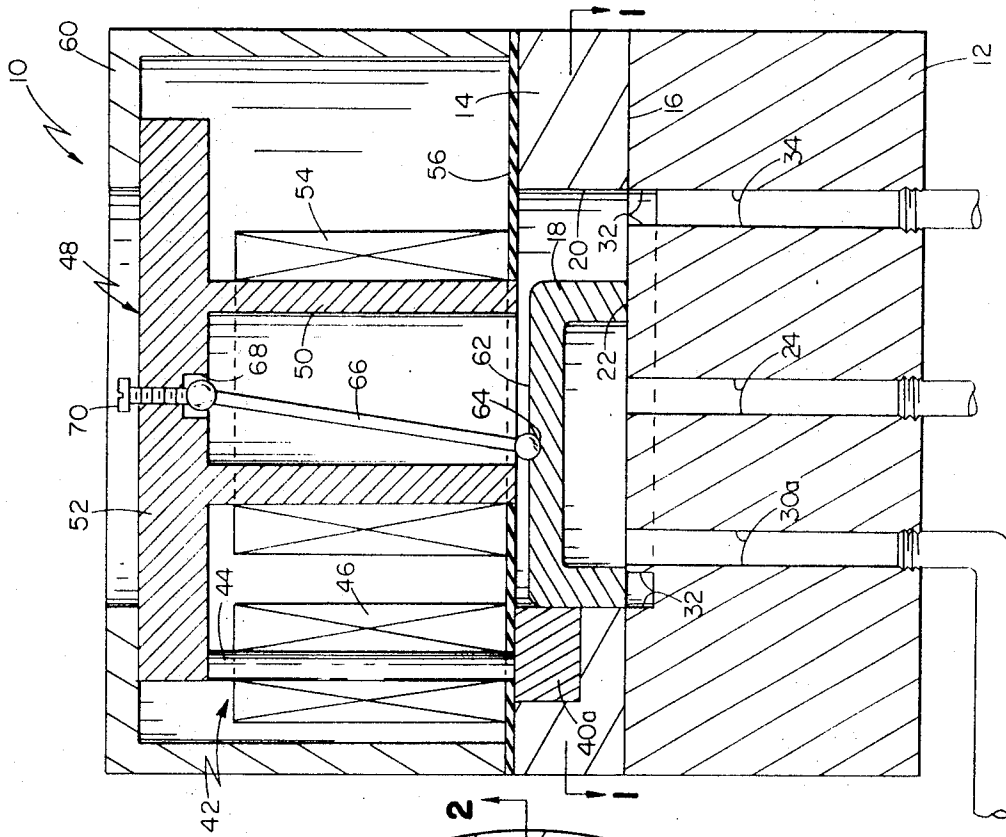

FIG 2

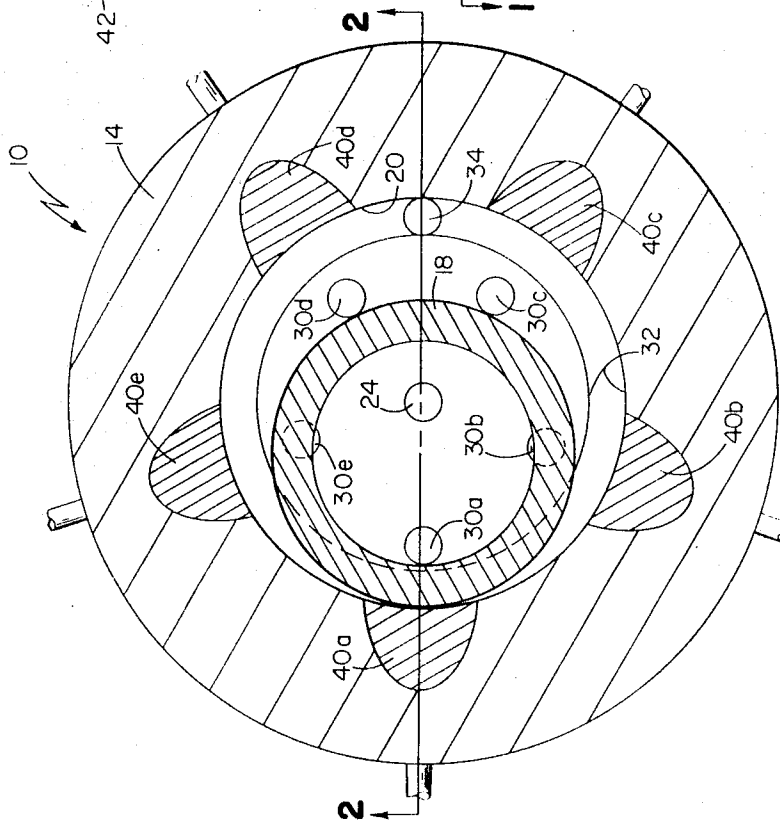

FIG 1

1

VALVING

This invention relates to valves.

It is a principal object of the present invention to provide a magnetically operated, low inertia, fast response, commutating valve. Other objects include providing simple, inexpensive and long-wearing valves of the type mentioned having a predetermined number of distinct valving positions, each position connecting one of a number of different sets of loads to a fluid source, and not more than half the predetermined number actuating magnetic coils.

The invention features a magnetic valve comprising a housing defining a valving surface and an inlet passage terminating at the surface in an inlet port, a valving member at least in part of magnetic material having a cavity extending inwardly from an opening in a surface thereof mounted on the housing with the surface thereof engaging the valving surface, an electromagnet for moving the valving member relative to the housing, and means for constraining movement of the valving member relative to the housing so that at least a portion of the inlet port is invariably within the bounds of the opening. In preferred embodiments in which an annular rim surrounds the cavity and at least three outlet ports in the housing valving surface are located outside and tangential to a circle having a diameter not less than the inner diameter of the annular rim there is featured outlet and inlet ports of diameter equal to the rim thickness, a magnetic coil radially aligned with each outlet port, and an annular ring surrounding the valving surface and a bearing rod having one end pivotally engaging the valving member and another end pivotally engaging a spaced support for constraining movement of the valving member to an orbital path about an axis perpendicular to the valving surface.

Other objects, features, and advantages will become apparent from the following detailed description of a preferred embodiment of the invention, taken together with the attached drawings, in which:

FIG. 1 is a view in transverse section of a magnetic valve embodying the invention; and,

FIG. 2 is a longitudinal section of the valve of FIG. 1.

Referring more particularly to the drawings, there is shown in FIGS. 1 and 2 an electromagnetic commutating valve 10 including a base 12 of circular cross section, a cylindrical ring 14 having an outside diameter equal to that of base 12 mounted on the flat upper surface 16 of base 12 coaxially therewith, and an inverted cup 18 mounted within the cylindrical cavity defined by the inner cylindrical surface 20 of ring 14 and surface 16 of base 12 with the rim 22 of cup 18 engaging surface 16.

A supply duct 24 is drilled, coaxially with the axis of base 12, downwardly from surface 16 through the base. Five load ducts, designated 30a through 30e and each having a diameter equal to the thickness t of rim 22, are arranged symmetrically around the outside of and are tangential to a circle of diameter D (where D is the inside diameter of rim 22) concentric with base 12. Each duct 30 extends from surface 16 downwardly through the base. An annular return channel 32, having an outer diameter equal to that of surface 20 (slightly greater than D plus $4t$) and a thickness equal to t , is cut in surface 16. A return duct 34 is drilled downwardly through base 12 from the bottom of channel 32.

Five magnetic pole pieces, designated 40a through 40e, are emplaced symmetrically around ring 14 with their inner edges flush with surface 20. Each of pole pieces 40 is radially aligned with a corresponding one of load ducts 30. Five electromagnets 42, each including a core 44 surrounded by a winding 46, are situated with the end of the core 44 of each magnet engaging a corresponding one of pole pieces 40. A spool 48, including a cylindrical portion 50 of length equal to that of electromagnets 42 extending downwardly from an upper plate 52, rests on the upper ends of cores 44. An electromagnetic winding 54 surrounds portion 50. A circular seal 56 with outer radius equal to that of base 12 lies on top of base 12 and separates windings 46 and 54 from cavity 12. Cores 44 and cylindrical portion 50 pass through holes in and are sealed to

seal 56. Spool 48 is held in place by a cover 60 attached to base 12.

As shown in FIG. 2, the upper surface 62 of cup 18 includes a semispherical depression 64. One end of bearing rod 66 fits pivotally in depression 64; the other end of rod 66 fits pivotally in a central well 68 in the lower surface of plate 52 of spool 48. An adjusting screw 70 threaded into plate 52 bears on the upper end of bearing rod 66 and is so adjusted that cup 18 is free to slide on surface 16 only with its periphery engaging the inner cylindrical surface 20 or ring 14. Cup 18 therefore orbits about surface 16 about the central axis of base 12 along a circular path having a diameter equal to the difference between the i.d. of surface 20 and the o.d. of the cup.

Pole pieces 40, cores 44, spool 48 and cup 18 are constructed of a ferromagnetic material. The other portions of the valve are of nonmagnetic material.

In operation, supply duct 24 is connected to a source of fluid pressure, and magnetic winding 54 and either two or three adjacent ones of magnets 42 are energized. The resulting magnetic force pulls cup 18 towards the pole pieces 40 of the energized magnets, permits fluid from supply duct 24 to flow to the load ducts 30 associated with the energized magnets, and places the other load ducts in fluid communication with annular return channel 32.

When, for example, the magnets of pole pieces 40a, 40b and 40e are energized, cup 18 assumes the position shown in FIGS. 1 and 2, tangent to surface 20 along a line in radial alignment with pole piece 40a, the central one of the energized pole pieces, and load duct 30a. In this position, at least a portion of each of load ducts 30a, 30b and 30e are in fluid communication with supply duct 24 and at least a portion of each of load ducts 30c and 30d are in fluid communication with annular return channel 32.

If the magnet associated with pole piece 40e is now deenergized (so that only pole pieces 40a and 40b are energized), cup 18 will move into a position tangent to surface 20 along a line midway between pole pieces 40a and 40b. In this second position, load ducts 30a and 30b are fluidly connected to supply duct 24 and load ducts 30c, 30d and 30e are fluidly connected to return channel 32.

By appropriate selection of the groups of two and three adjacent ones of magnets 42 energized, cup 18 may be positioned in any one of 10 distinct positions, five positions adjacent and five positions intermediate load ducts. In each position, fluid under pressure from supply duct 24 is supplied to the load ducts 30 associated with the energized magnets 42.

Valve 10 is particularly useful in conjunction with the fluid stepping motor disclosed in my heretofore filed application entitled "positioning," Ser. No. 832,223, filed June 11, 1969.

Other embodiments within the scope of the following claims will occur to those skilled in the art.

I claim:

1. A magnetic valve comprising:

a housing defining an inlet passage, at least three outlet passages, and a valving surface, said inlet passage terminating at said valving surface in an inlet port, and each of said outlet passages terminating at said valving surface in an outlet port;

a valving member at least in part of magnetic material having a cavity extending inwardly from an opening in a surface thereof mounted on said housing with said surface thereof engaging said valving surface;

an annular rim surrounding said cavity;

means including at least three relatively spaced electromagnets for moving said valving member relative to said housing; and

means for constraining movement of said member relative to said housing so that at least a portion of said inlet port is invariably within the inner bound of said opening during said movement, said outlet ports being relatively spaced around and tangential to the circumference of a circle of diameter not less than the inside diameter of said rim.

2. The valve of claim 1 wherein said outlet ports are regularly spaced and said electromagnets are regularly spaced around the circumference of a circle concentric with and of greater diameter than the circle of said outlet ports.

3. The valve of claim 2 wherein an electromagnet is radially aligned with each of said outlet ports.

4. The valve of claim 1 wherein said valving member is constrained to orb on a circular path on said surface about an axis perpendicular to said surface.

5. The valve of claim 4 wherein said means for constraining movement includes a connecting member pivotally connected to said valving member and to a support spaced from said valving member.

6. The valve of claim 5 wherein one end of said connecting member is mounted in a recess in a surface of said valving member opposite said cavity and another end of said connecting member is mounted in a facing recess in said support, and including means for varying the distance between the bases of said recesses.

7. The valve of claim 5 wherein said valving surface is

planar and said valve defines a cylindrical surface coaxial with said inlet port and perpendicular to said valving surface.

8. The valve of claim 7 said outlet ports are arranged around and tangential to the circumference of a circle concentric with said cylindrical surface.

9. The valve of claim 8 wherein the diameter of each of said outlet ports is equal to the thickness of said rim.

10. The valve of claim 8 wherein the diameter of said cylindrical surface is approximately equal to the inside diameter of said rim plus four times the thickness of said rim.

11. The valve of claim 8 including not less than three electromagnets relatively spaced exteriorly of said cylindrical surface.

12. The valve of claim 11 wherein said outlet ports and said electromagnets are regularly spaced.

13. The valve of claim 12 wherein an electromagnet is radially aligned with each of said outlet ports.

14. The valve of claim 1 including an electromagnet mounted coaxially with said inlet port.

25

30

35

40

45

50

55

60

65

70

75