

(19) **DANMARK**

(10) **DK/EP 2306001 T3**



Patent- og
Varemærkestyrelsen

(12) **Oversættelse af
europæisk patentskrift**

-
- (51) Int.Cl.: *F 03 D 7/02 (2006.01)* *F 03 D 9/10 (2016.01)* *F 03 D 9/11 (2016.01)*
F 03 D 9/25 (2016.01) *H 02 J 3/24 (2006.01)* *H 02 J 3/32 (2006.01)*
H 02 J 3/38 (2006.01)
- (45) Oversættelsen bekendtgjort den: **2019-10-14**
- (80) Dato for Den Europæiske Patentmyndigheds bekendtgørelse om meddelelse af patentet: **2019-07-10**
- (86) Europæisk ansøgning nr.: **10178462.7**
- (86) Europæisk indleveringsdag: **2010-09-22**
- (87) Den europæiske ansøgnings publiceringsdag: **2011-04-06**
- (30) Prioritet: **2009-09-25 US 566739**
- (84) Designerede stater: **AL AT BE BG CH CY CZ DE DK EE ES FI FR GB GR HR HU IE IS IT LI LT LU LV MC MK MT NL NO PL PT RO SE SI SK SM TR**
- (73) Patenthaver: **General Electric Company, 1 River Road, Schenectady, NY 12345, USA**
- (72) Opfinder: **Burra, Rajni Kant, GE India Technology Centre Pvt. Ltd., 122 , EPIP, Phase II, Hoodi Village, Whitefield Road, 560066 Bangalore, Indien**
Delmerico, Robert William, GE Global Research , One Research Circle , Patent Doc Room, Building K1-4A59, Niskayuna, NY 12309, USA
Bose, Sumit, GE Global Research , One Research Circle , Patent Doc Room, Building K1-4A59, Niskayuna, NY 12309, USA
Chandrashekhara, Divya Kurthakoti, GE India Technology Centre Pvt. Ltd., 122 , EPIP, Phase II, Hoodi Village, Whitefield Road, 560066 Bangalore, Indien
- (74) Fuldmægtig i Danmark: **COPA COPENHAGEN PATENTS K/S, Rosenørns Allé 1, 2. sal, 1970 Frederiksberg C, Danmark**
- (54) Benævnelse: **Energilagring til vedvarende kilder, med flere anvendelsesmuligheder**
- (56) Fremdragne publikationer:
DE-A1-102007 046 239
US-A1- 2006 171 086
US-A1- 2008 150 282
US-A1- 2009 230 689

DESCRIPTION

[0001] The invention relates generally to renewable energy sources and more specifically to the use of energy storage in conjunction with renewable energy sources. The invention additionally relates to grid frequency stabilization of grid connected renewable energy sources.

[0002] Wind-turbine generators (WTGs) and wind-plants are typically designed to deliver constant active and reactive power to a utility grid with the delivered power being independent of system frequency. See, for example, US 2009/0230689. This is accomplished by decoupling the rotor inertia and speed from the grid using fast acting power electronics and controls. Due to increases in wind-plant size and penetration, some utilities are now requiring that wind-plant and wind-turbine controls provide enhanced capabilities such as frequency stabilization.

[0003] At present wind turbines do not provide frequency regulation services, which are quite essential for maintaining stability (power balance) of the electric power system. Another factor for improving power system stability in wind turbines is inertia response. Generally, inertia controllers use rotor kinetic energy in response to frequency deviations on the grid. For example, if the frequency of the grid goes below the nominal value, the kinetic energy of the rotor is used to export electric power to the grid. This results in the slowing down of the rotor. Similarly, if the frequency of the grid increases above the nominal value, then the kinetic energy of the rotor is increased by importing electric power from the grid. This results in the speeding up of the rotor. Since there is a continuous dithering of frequency on the grid, the inertia controller in response to the frequency tends to cause the rotor speed and/or acceleration to dither. If the rotor mode of oscillation is in the proximity of the grid mode of oscillation, the coupled behavior may excite the resonance. Therefore, the use of rotor inertia for continuous frequency response may not be always possible. Thus, it would be desirable to have a system and method to efficiently address variability of renewable energy to help satisfy the related utility company requirements.

[0004] Hence, the present invention, as defined by the appended claims, is provided.

[0005] Various features, aspects, and advantages of the present invention will become better understood when the following detailed description is read with reference to the accompanying drawings in which like characters represent like parts throughout the drawings, wherein:

FIG. 1 is a high level block diagram of a typical wind power generation system;

FIG. 2 is a diagrammatical representation of a wind power generation system including an energy storage device in accordance with an embodiment of the present invention;

FIG. 3 is a diagrammatical representation of a wind power generation system including an energy storage device in accordance with another embodiment of the present invention; and

FIG. 4 is a high level block diagram of a detailed stabilization control system in accordance with

an embodiment or the present invention;

[0006] As discussed in detail below, various embodiments of the present invention function to provide a system and a method for transferring power from renewable energy sources to a power grid for stabilizing the grid frequency.

[0007] Referring generally to FIG. 1, a wind turbine system 110 operable to generate electric power is illustrated. The wind turbine system 110 comprises a hub 112 having multiple blades 114. The blades 114 convert the mechanical energy of the wind into a rotational torque, which is further converted into electrical energy by the wind turbine system 110. The wind turbine system 110 further includes a turbine portion 116 that is operable to convert the mechanical energy of the wind into a rotational torque and a power conversion system 118 that is operable to convert the rotational torque produced by the turbine portion 116 into electrical power. A drive train 120 is provided to couple the turbine portion 116 to the power conversion system 118. The wind turbine power conversion system 118 typically comprises a doubly fed asynchronous generator with a power electronic converter for rotor field control or a synchronous generator for use with a full power electronic converter interface to collector system 134. The collector system generally includes turbine transformers, feeder cables and breakers up to the substation transformer. It should be noted that the collector system is a part of the power grid where the power grid usually refers to the metering point and beyond.

[0008] The turbine portion 116 includes a turbine rotor low-speed shaft 122 that is coupled to the hub 112. Rotational torque is transmitted from rotor low-speed shaft 122 to a generator shaft 124 via drive train 120. In certain embodiments, such as the embodiment illustrated in FIG. 1, drive train 120 includes a gear box 126 transmitting torque from low-speed shaft 122 to a high speed shaft 130. High speed shaft 130 is coupled to power conversion system shaft 124 with a coupling element 128.

[0009] Power conversion system 118 is coupled to wind turbine controls 144. Wind turbine controls 144 receive signals 146 from the power conversion system that are representative of the operating parameters of the system. Wind turbine controls 144, in response, may generate control signals, for example a pitch signal 156 to change the pitch of blades 114 or a torque signal for the power conversion system. Wind turbine controls 144 are also typically coupled to a wind plant controller 132.

[0010] FIG. 2 illustrates a wind power generation system 40 in accordance with an embodiment of the present invention. The system 40 includes wind turbine blades 42, a wind generator 43, a first AC to DC converter 44 coupled to a DC link 46 and a DC to AC inverter 48 which feeds electrical power to the collector system 50 which is part of the power grid. The system 40 further includes one or more energy storage devices 54 which are coupled to the DC link 46 via one or more respective bidirectional DC to DC converters 56. In one embodiment, for example, an energy storage device may comprise a supercapacitor or an

electrochemical battery or combinations thereof. A stabilization control logic 58 provides commands to an energy storage controller 60, which controls a bidirectional DC to DC converter 56 based on the grid condition. The stabilization control logic 58 further provides commands to an inertia controller 62, which generates control signals, with one example being a transient pitch signal to the wind turbine controller 63 for changing the pitch of blades 42 or a transient torque signal to the wind turbine controller 63 for controlling the AC to DC converter 44. The wind turbine controller 63 also receives signals from the collector system 50 that are representative of the operating parameters of the system and a wind plant controller 64. The wind turbine controller 63, in response, may generate control signals such as a pitch signal and a torque signal for the power conversion system.

[0011] In one embodiment, the stabilization control logic 58 identifies the existence of fluctuations or disturbances in the grid frequency and provides a first transient power signal or first transient torque signal to the inertia controller 62. In one embodiment, the first transient power signal from the inertia controller 62 comprises two signals and, more specifically, a torque command ΔT and a turbine speed command ΔS . In other embodiments, the first transient power signal comprises at least one of a power command, a torque command, and a speed command. The first transient power signal is typically further constrained so as to limit oscillatory coupling. The inertia controller 62 then uses the first transient power signal to generate a transient blade pitch control signal to adjust the pitch of the blades, a transient generator speed command signal, and or a first transient converter power command in order to stabilize the power generation system.

[0012] In one embodiment, if the inertia controller provides a first transient converter power command that is not positive, the stabilization control logic 58 provides a second transient power signal to the energy storage controller 60. The transient power command from the inertia controller would not be positive if the generator speed limits are reached or if a grid signal deviation falls within the inertia controller deadband. In one embodiment, the inertia controller deadband is in the range of 0.2 Hz to 2 Hz. The first transient power command from the inertia controller may also not be positive if the generator speed is not constant and is lower than the pre-disturbance generator speed or if the rate of change of the frequency is greater than zero. If the first transient command from the inertia controller is positive, then the stabilization control logic 58 does not provide any transient power signal to the energy storage controller 60, and the state of the energy storage does not alter. That is, the energy storage neither charges or discharges.

[0013] When the stabilization control logic 58 provides the second transient power signal to the energy storage controller 60 so that the energy storage controller provides the second power command to the converter, the converter 56 then provides the demanded transient power to the DC link from the energy storage device. In one example, the transient power or the temporary power boost may be increased by five to ten percent for up to ten seconds.

[0014] The use of stored energy for providing a transient response has several benefits in addition to grid stability, including, for example, use of stored energy that would not otherwise

be available at the turbine output without the need to build in operating margin (such as by curtailed mode operation). In one embodiment, the energy storage device is charged during normal operation of the wind power generation system. For example, when there is no dip in the grid frequency or when the wind generator is supplying excess power, the stabilization control logic 58 may command the energy storage controller 60 and in turn the bidirectional converter 56 to fetch active power from the wind generator 43 via the first AC to DC converter 44 to charge the energy storage device 54. The stabilization control logic may provide a control signal to charge the energy storage device provided the power command signal from the inertia controller is not negative.

[0015] FIG. 3 illustrates an alternative wind power generation system 70 in accordance with an embodiment of the present invention. In this embodiment, the energy storage device 54 is connected to AC side 72 of the DC to AC inverter 48. Thus, a bidirectional DC to AC converter 74 is utilized to transfer DC power from the energy storage device to the AC grid. It will be appreciated by those skilled in the art that a plurality of energy storage devices and a plurality of bidirectional DC to AC converters may also be employed in another embodiment. In one embodiment, the stabilization control logic 58 provides a transient power signal to the converter 44 and/or to the converter 74 through energy storage controller 60 and/or the wind turbine controller 63 based on the fluctuations in the grid frequency and the status of the inertia controller as described earlier. The embodiment of FIG. 3 will typically have lower installation and interconnection costs than the embodiment of FIG. 2. The coupling of the bidirectional converter 74 to the DC to AC converter may be either by direct connection to the DC to AC converter or by connection through the transformer 52 and/or power lines between the DC to AC converter and the grid. Thus, the bidirectional converter 74 may be situated either near the DC to AC converter or at a remote location, such as two to three miles from the DC to AC converter.

[0016] FIG. 4 represents a detailed stabilization control system 200 of a renewable power generation system in accordance with an embodiment of the present invention. The control system 200 includes a stabilization control logic 206, an inertia controller 202, and an energy storage controller 204. The stabilization control logic 206 comprises a deadband limiter 208, a second deadband limiter 210, and a logic module 212. In one embodiment, the inputs to the stabilization control logic are a signal 214 of the power generation system and a first converter transient power command signal 216 of inertia controller. The signal 214 may comprise any appropriate signal with one example comprising a signal corresponding to power generation system frequency. In another embodiment, the signal 214 may include a voltage signal, a current signal, a power signal, or combinations thereof. The signal may be obtained either by direct measurement of the respective signal or by measurement of another signal and computations to obtain the respective signal.

[0017] The first deadband limiter 208 is configured for detecting when the signal 214 of the power generation system is outside of a signal range or a frequency band. If the signal 214 is outside of the specified signal range, the control logic 206 provides a first transient power command signal 220 to the inertia controller 202. The inertia controller 202 then provides the

first transient power signal to the turbine controller if the generator speed 218 has not reached its limit. The first deadband limiter 208 is used to limit the response of inertia controller 202 to sufficiently large events. Frequency will always vary somewhat due to dithering that occurs when loads come on and off the system. For example, load variation typically affects frequency by about 0.05 Hz, depending on the system. The inertia controller 202 is used for more significant events that occur when a sudden difference is present between load and generation such as a utility system losing a large generator or a transmission line tripping. In one example, the deadband is set a plus or minus 0.12 Hz off the center point frequency. The selection of this limit is typically based on factors such as the location and nature of the power generation system and the variability of frequency center points. Stabilization system 200 may have a variable limit that is set by the end user after taking into account such factors.

[0018] The second deadband limiter 210 of the stabilization control logic 206 detects when the signal 214 is within a signal range. In one embodiment the signal range is 0.2 Hz to 2 Hz. The logic module provides a positive signal if the rate of change of frequency is greater than zero and if the first transient power command from the inertia controller is not positive. As described earlier, the first transient converter power command would not be positive if the generator speed limits are reached or if the grid frequency deviation falls within the inertia controller deadband. The first converter power command from the inertia controller may also not be positive if the wind speed is not constant and it is lower than the pre-disturbance wind speed or if the rate of change of the frequency is greater than zero. If the signal from the logic module is positive and the signal is 214 is within the specified range, then the stabilization control logic 206 provides a second transient power signal 222 to the energy storage controller 204. The second transient power signal 222 may be to charge the energy storage or to discharge the energy storage device by providing power to the grid. The energy storage device is charged when the wind power generation exceeds the load provided the first power command signal from the inertia controller is not negative. Thus, when the signal 214 is outside of a signal range, inertia controller operates to provide transient power and when the signal 214 is within the signal range the energy storage controller operates to provide the transient power resulting in continuous frequency stabilization of the system.

[0019] One unique feature of this wind turbine system is that it allows the wind turbines to provide transient response even during no or low wind periods. The advantage of the scheme is improved frequency stability of the power system by providing inertia response and primary frequency regulation provided by coupling the wind inertia response and the energy storage. The inertia response reduces the magnitude of rate of change of frequency and thereby reduces the magnitude of frequency peak. Additionally, although wind turbines are illustrated as the energy sources, the concepts disclosed herein are believed to be applicable to any non-conventional energy sources with several other examples including solar power generation systems, microturbines, and fuel cells.

[0020] While only certain features of the invention have been illustrated and described herein, many modifications and changes will occur to those skilled in the art. It is, therefore, to be understood that the appended claims are intended to cover all such modifications and changes

as fall within the scope thereof.

REFERENCES CITED IN THE DESCRIPTION

This list of references cited by the applicant is for the reader's convenience only. It does not form part of the European patent document. Even though great care has been taken in compiling the references, errors or omissions cannot be excluded and the EPO disclaims all liability in this regard.

Patent documents cited in the description

- [US20090230689A \[0002\]](#)

KRAV

- 1.** Et elproduktionssystem (40), der omfatter et vindmøllevingeaggregat (42);
- 5

en generator (43), der er mekanisk koblet til vingeaggregatet (42);

en effektomformer (44, 48) koblet til generatoren (43);

en energilagingsindretning (54);

en tovejsomformer (56,74), der kobler energilagingsindretningen (54) til effektomformerens (44,48);
- 10

en inertistyringsenhed (62), der er konfigureret til at tilvejebringe et første transient signal til at regulere aktiv effekt fra vindmøllesystemet når et elnetsignal er uden for et respektivt signalområde; og

en energilagingsstyringsenhed (60) konfigureret til at tilvejebringe et andet transient signal til tovejsomformerens (56,74) til at regulere en effekt til eller fra energilagingsindretningen (54)
- 15

baseret på det første transiente signal for at stabilisere elnettets netfrekvens (50).

- 2.** Elproduktionssystem (40) ifølge krav 1, hvor tovejsomformerens (56) er koblet mellem energilagingsindretningen (60) og en DC-forbindelse (46) i effektomformerens (44,48).

- 20

3. Elproduktionssystem (40) ifølge et hvilket som helst af de foregående krav, hvor tovejsomformerens (56) er koblet mellem energilagingsindretningen (60) og en udgangsside (72) af effektomformerens (44,48).

- 4.** Elproduktionssystem (40) ifølge et hvilket som helst af de foregående krav, hvor
- 25

inertistyringsenheden (62) yderligere er konfigureret til at forhindre det første transiente signal i at forårsage at produktionssystemet (43) opererer uden for mindst én driftsbegrænsning.

- 5.** Elproduktionssystem (40) ifølge et hvilket som helst af de foregående krav, hvor elnetsignalet omfatter et elproduktionssystemsfrekvenssignal.
- 30

6. Elproduktionssystem (40) ifølge et hvilket som helst af de foregående krav, hvor elnetsignalet omfatter et spændingssignal, et strømsignal, et effektsignal eller kombinationer deraf.

- 7.** Elproduktionssystem (40) ifølge et hvilket som helst af de foregående krav, hvor det første
- 35

transiente signal omfatter en effektkommando, en momentkommando, en

turbinehastighedskommando eller kombinationer deraf.

- 5 **8.** Elproduktionssystem (40) ifølge et hvilket som helst af de foregående krav, hvor det andet transiente signal omfatter et opladningssignal eller et afladningssignal til energilagringssystemet (54).
- 10 **9.** Elproduktionssystem (40) ifølge et hvilket som helst af de foregående krav, som yderligere omfatter stabiliseringsstyringslogik (58) koblet til energilagringssystemet (60) og inertistyringsenheden (62).
- 15 **10.** Energiproduktionssystem (40) ifølge krav 9, hvor stabiliseringsstyringslogikken (58) tilvejebringer et andet transient effektsignal til energilagringssystemet (60), således at energilagringssystemet (60) tilvejebringer en anden effektkommando til tovejsomformereren (56,74), hvor tovejsomformereren (56,74) derefter leverer den krævede transiente effekt til en DC-forbindelse (46) fra energilagringssystemet (54).
- 20 **11.** Energiproduktionssystem (40) ifølge krav 9 eller krav 10, hvor hvis inertistyringsenheden (62) tilvejebringer en første transient effektkommando, som ikke er positiv, så tilvejebringer stabiliseringsstyringslogikken (58) et andet transient effektsignal til energilagringssystemet (60).
- 25 **12.** Energiproduktionssystem (40) ifølge krav 11, hvor den transiente effektkommando fra inertistyringsenheden (62) ikke er positiv hvis generatorhastighedsgrænserne nås, eller hvis en elnetssignalafvigelse falder inden for inertistyringsenhedens (62) dødbånd.
- 30 **13.** Elproduktionssystem (40) ifølge krav 12, hvor inertistyringsenhedens (62) dødbånd ligger i området fra 0,2 Hz til 2 Hz.
- 14.** Energiproduktionssystem (40) ifølge et hvilket som helst af kravene 9 til 12, hvor hvis en første transient kommando fra inertistyringsenheden (62) er positiv, så tilvejebringer stabiliseringsstyringslogikken (58) ikke noget transient effektsignal til energilagringssystemet (60).

15. Fremgangsmåde til stabilisering af et vindenergiproduktionssystem (110) der omfatter elproduktionssystemet (40) ifølge et hvilket som helst af de foregående krav, hvor fremgangsmåden omfatter:

5

tilvejebringelse af et første transient elproduktionssignal til at regulere en effekt fra en vindmøllerotor (112) når et netfrekvenssignal ligger uden for et respektivt signalområde; og

tilvejebringelse af et andet transient elproduktionssignal til at regulere en effekt fra energilagringen (54) baseret på det første transiente elproduktionssignal for at stabilisere elnettets netfrekvens.

10

DRAWINGS

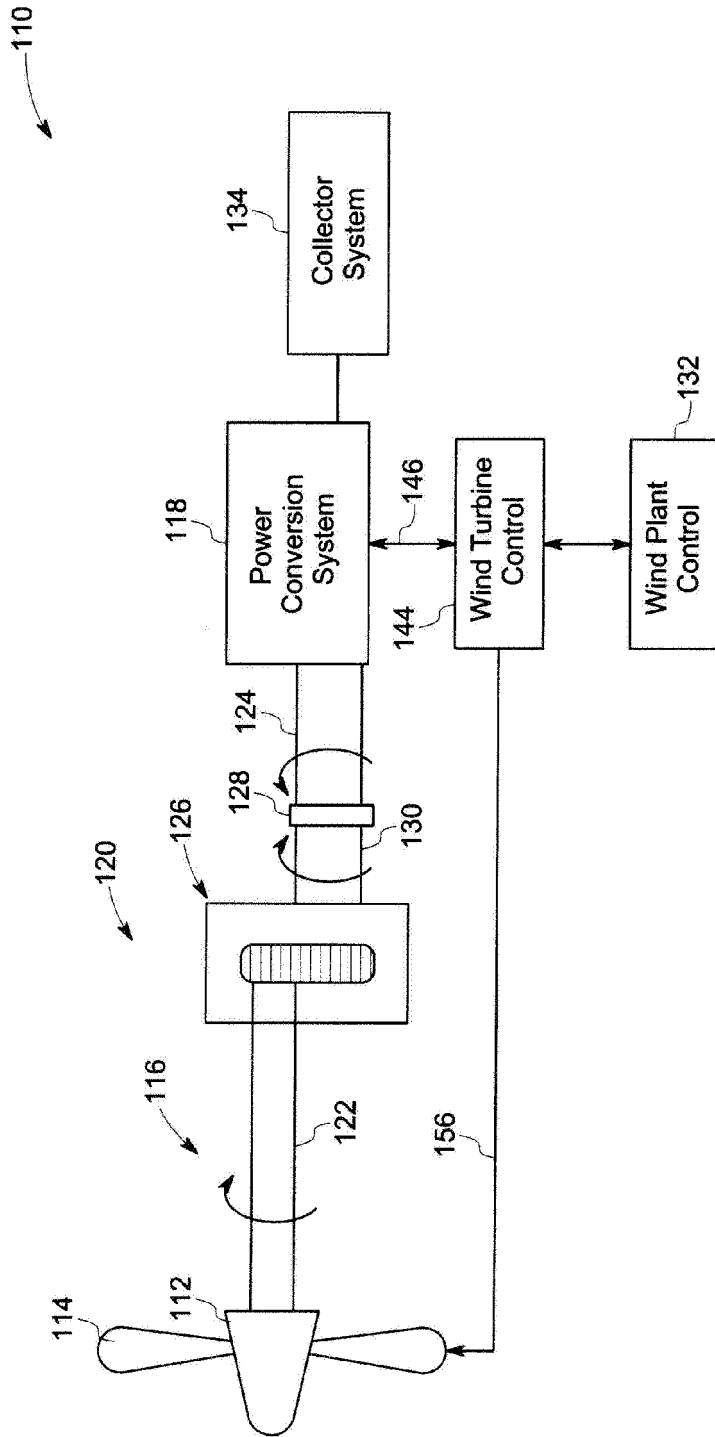

FIG. 1

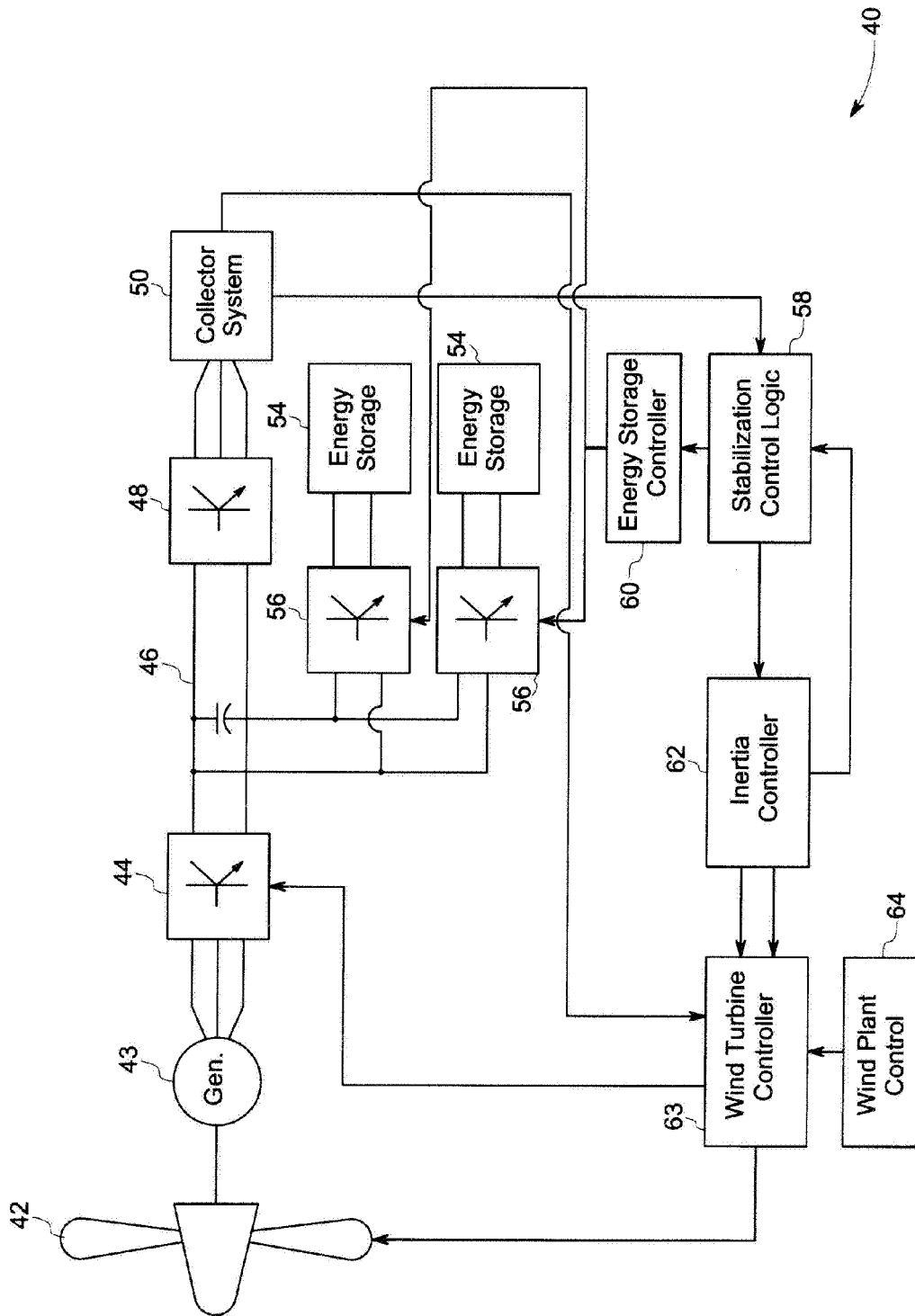

FIG. 2

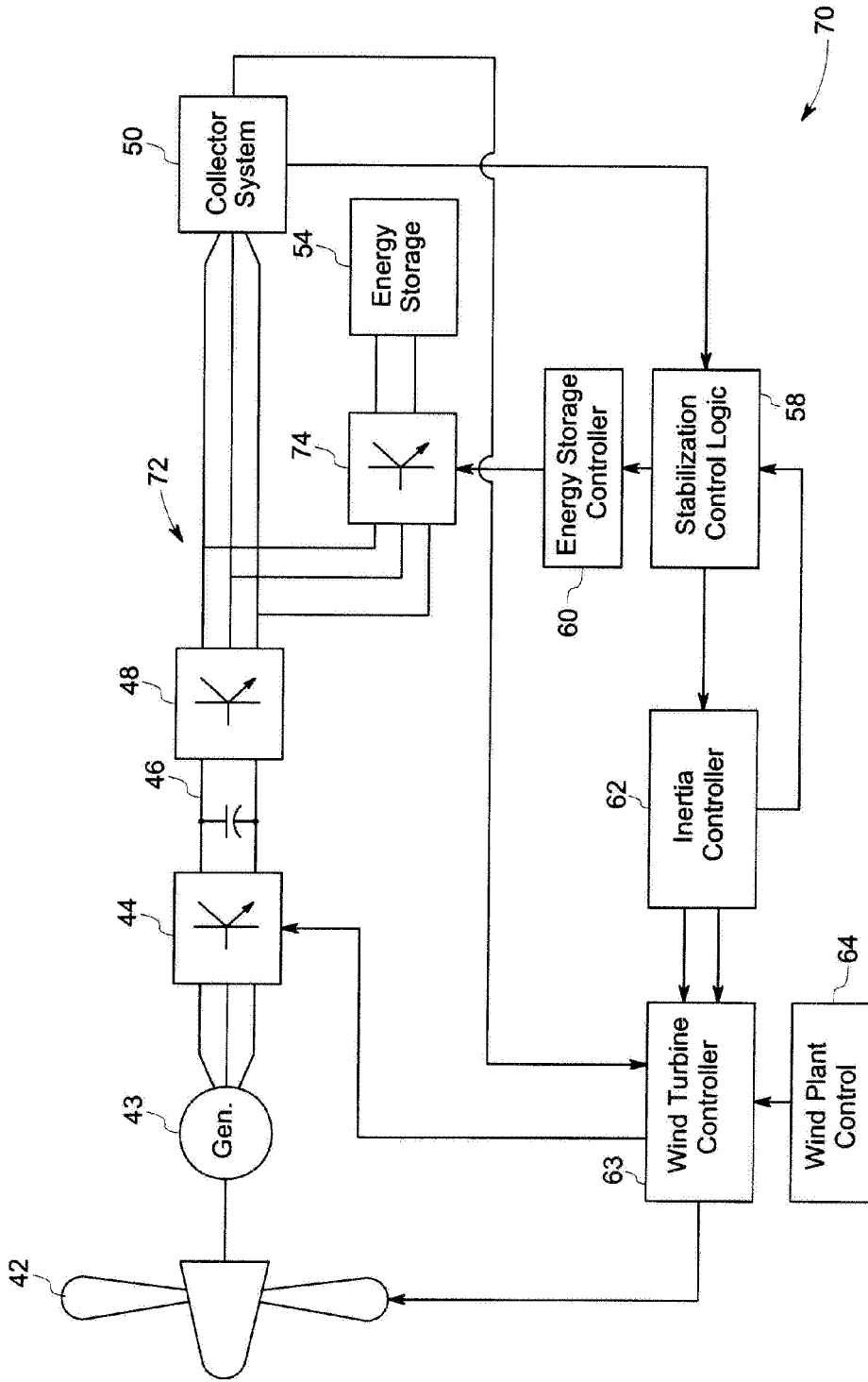

FIG. 3

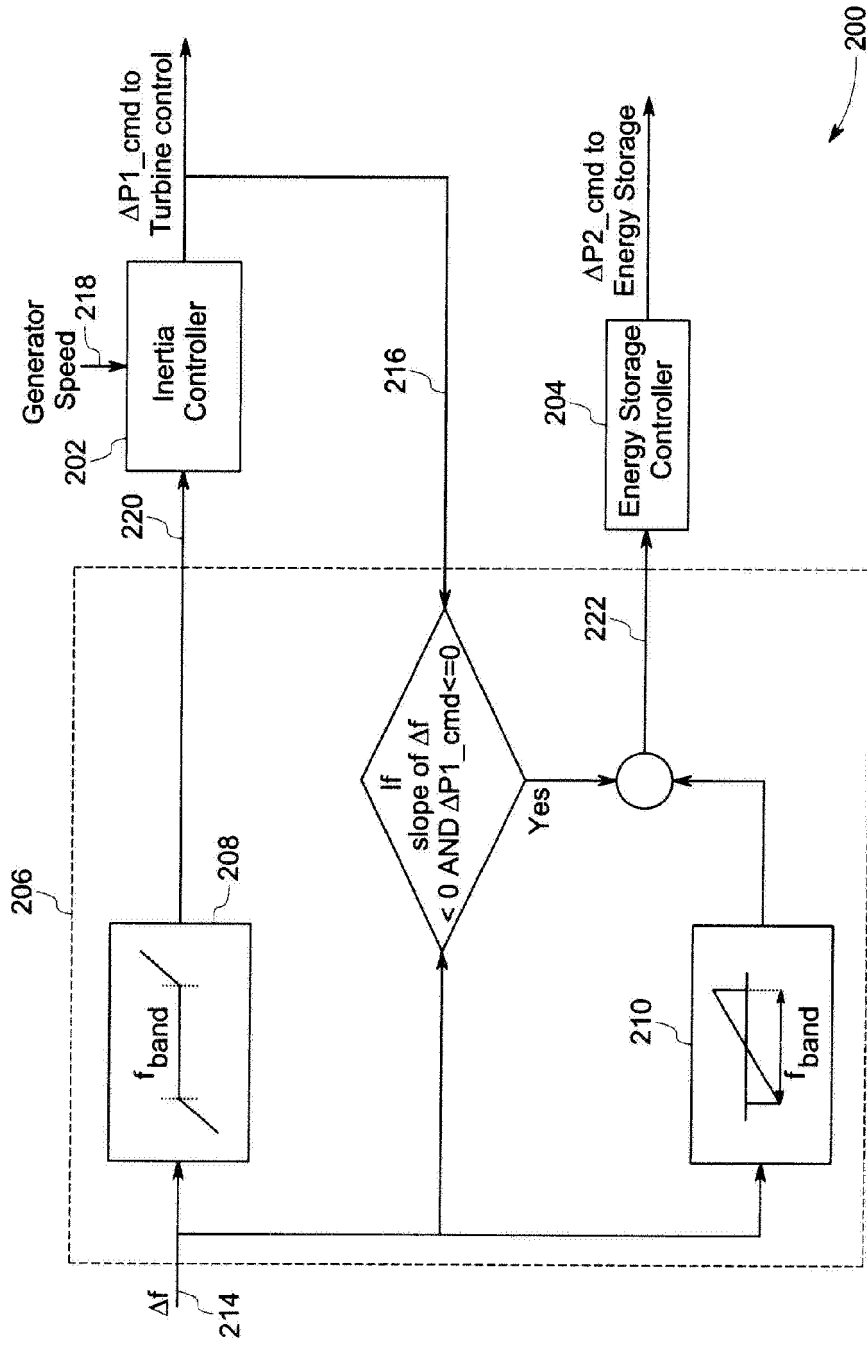

FIG. 4