

(19)
(12)

(KR)
(A)

(51) 。 Int. Cl. 7
G02F 1/1337

(11)
(43)

2003-0033833
2003 05 01

(21) 10-2001-0065988
(22) 2001 10 25

(71) . 20

(72) 2 930-43

(74)

:

(54)

가 , 2 , 가 1, 2
1, 2 , 1, 2
1, 2

13

1a 1e TDTN .

2 TDTN .

3 TDTN .

4 .

5 .

6a 6d TDTN
 7 TDTN
 8
 9
 10 DDTN
 11a 11e DDTN
 12
 13 DDTN

*
 108 : 109 :
 110 : 111 : 1
 112 : 2 113 :
 114 : 115a, 115b : 1 , 2
 118 : 119 :
 120 :

(LCD ; Liquid Crystal Display Device)
 DDTN

(TN : twisted nematic)
 가 90°

, 가
 , TN (twisted nematic mode)

LCD 가 ,
 (Film-compensated mode),
 (Multi-Domain Mode),
 -Plane Switching Mode)

가 IPS (In

1a 1e TDTN , 2 TDTN
 , 3 TDTN

4, 5

TN, FDTN(Four Domain TN), TDTN(Two D

omain TN), 4, ITO (11), (10)

, TDTN 1a, (12), (13), 1

, 1b, 1d, 1, (12), (15)

, 1e, (15), 2, 1, 2, 2-

, 2, 2

, (·)

, (polyimide), (polyamide)

, 3, (10a,10b) (

14), (10a) ITO (11a) () ,

R,G,B () (4 '16') (4 '17') ,

(11b) 가 (4 '18')가

TDTN I, I

.(2)

, NW(Normally White) (dark state) (disclination line)

, 가

16), (17), (18) (19) 4, (

, (19) Cr, CrOx

, 가 5, (29)

, 가 TDTN(Two-

Domain TN) 가

6a 6d TDTN, 7

TDTN, 8

TDTN 6a 6b, ITO (31) (30)

(32) (32) (33) (35) (UV:Ultra-Violet Ray) 6c

, 6d

2-

(32)

(B) 8 (A)

7 (30a) (30a,30b) (30b) (34)

R,G,B ITO ITO 가

TDTN (30a) (30b)

가 1 1

VA

, VA 가 가

가 가 가

VA

(side-electrode), (rib) (slit)

가 9 (49) (49)

(48)

(45)가 1 (40) (46) (47) (48)

(48) (40) (40,41) TN (42) (44) 2 (4

1) 1, 2 (49)

(49)

(42a)가 (49),

가

가 가 가

가

가

가 - (reverse tilt)

가

가

가

가

2 , 가 1, 2

1 , 2 , 1, 2

1 2 , 1, 2

1, 2

10

DDTN

11a

11e

DDTN

13

DDTN

10 (101)

(102)

가

1

()

(101)

(101a)

(101a)

(103), (102b)

(102)

()

(101a) (103)

/

(102a)

(102b)

가

(107)

ITO

(107)

(102b)

(113)

(120) (113) (turn-on) (120) (113) 가 가 (120) +,x .

(120) 가

11a 1 (115a) (113) 1 (111) (119) 1 (115a) 1

V 11b 1 (115a) 1 (115a) (118) U

(118) 12 (A)가 (B)가 (A)

2 (112) (108) R,G,B (108) (109) 1 (111) (113) (114) .(13)

11c 2 (115b) (114) 2 (112) (119) 2 가 (115b)

1 2

UV 11d 2 (115b) 2 (115a) (118)

1, 2 (115a, 115b) (polysiloxane-cinnamate) (polycinnamate) (polyazobenzen)

(deep) UV, (mid) UV

11e (112) (110) 1 (111) 1, 2 (111,112) () 2

(110) 가

2 (115b) () 가 (110a) 13 1 (115a)

1, 2 가 - 가

가 (reverse tilt domain) 가 -

DDTN TDTN

가 .

가 -

가

가 .

(57)

1.

가 , 1 ;

1 2 ;

1, 2 ;

1, 2 가 , 1, 2

2.

1 ,

3.

1 ,

4.

1 2 ;

1

;

1, 2

가 1, 2 ;

1, 2

5.

4 , 1, 2 2

6.

5 , 2 ,

1, 2 1, 2 ;

1 1 2 2

7.

6 ,

8.

6

9.

4

10.

4

1, 2

1a

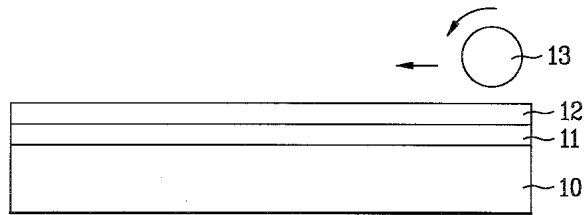

1b

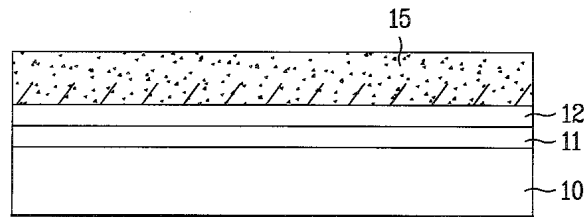

1c

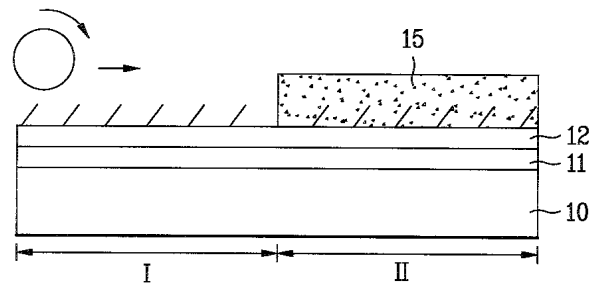

1d

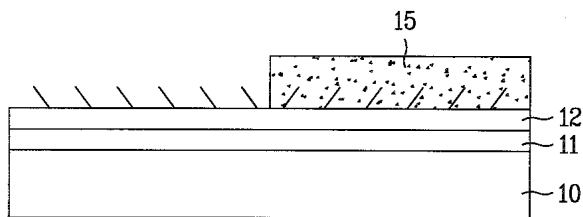

1e

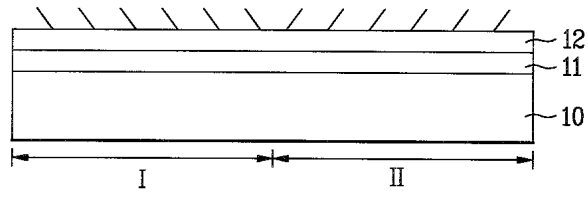

2

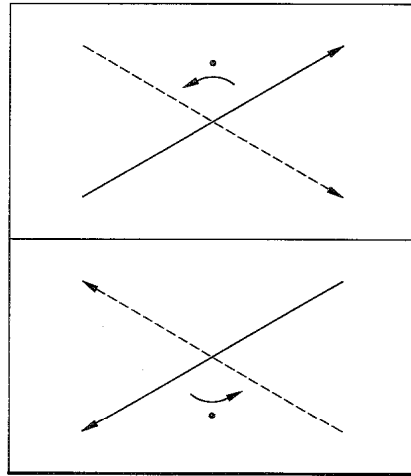

3

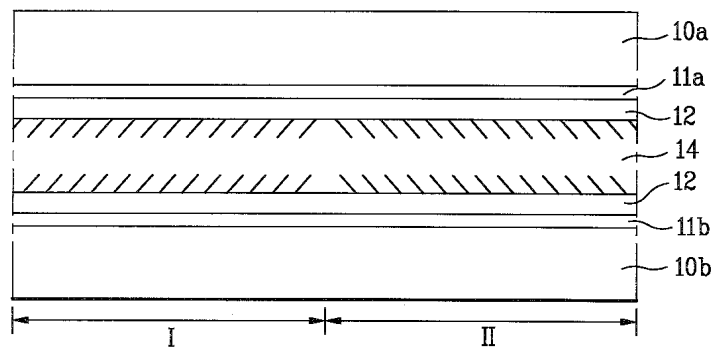

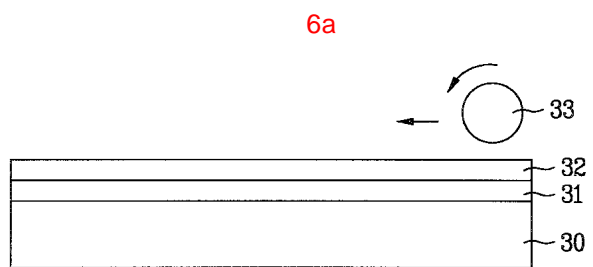
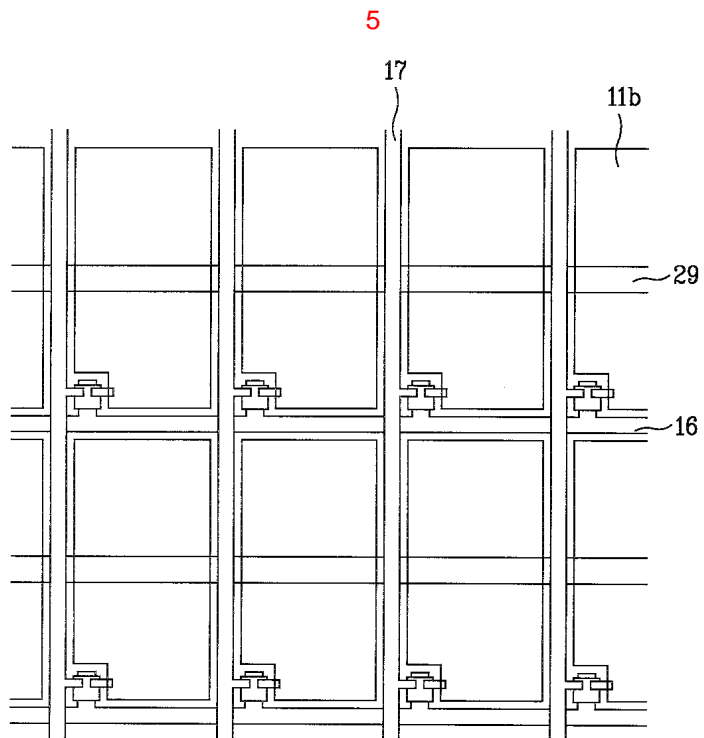
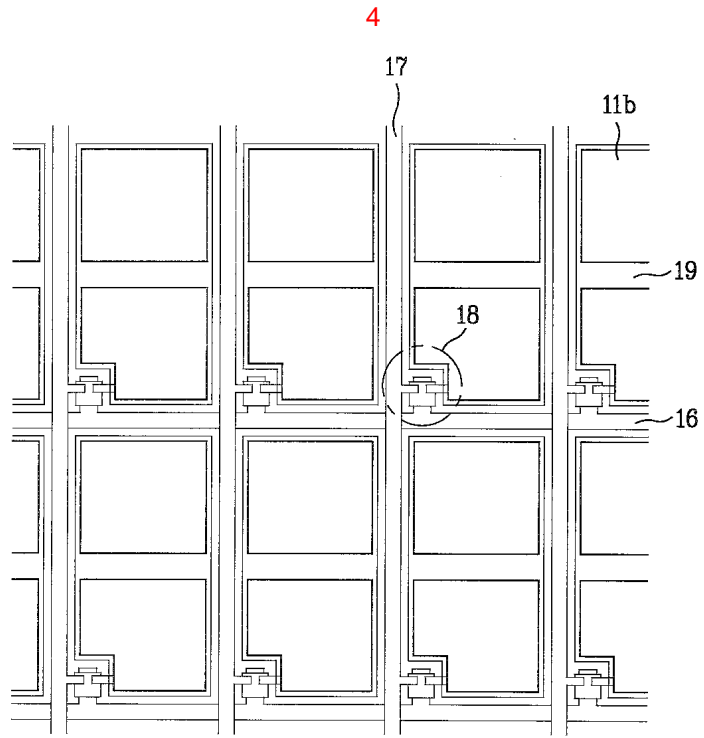

6b

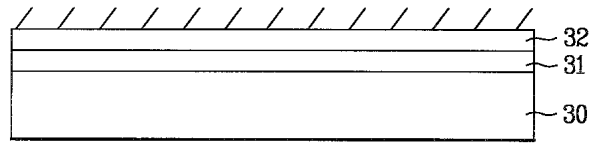

6c

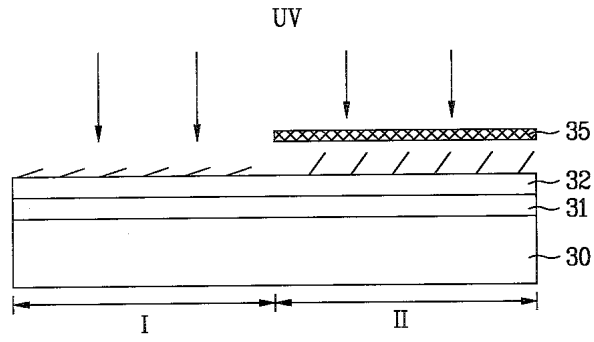

6d

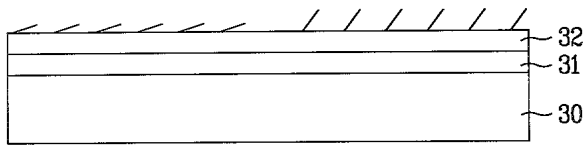

7

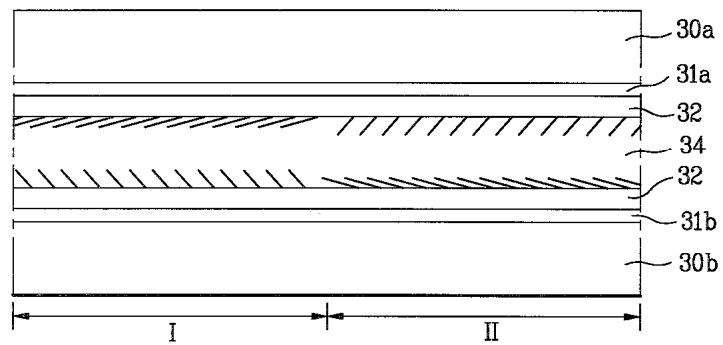
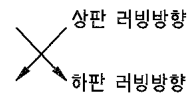

8

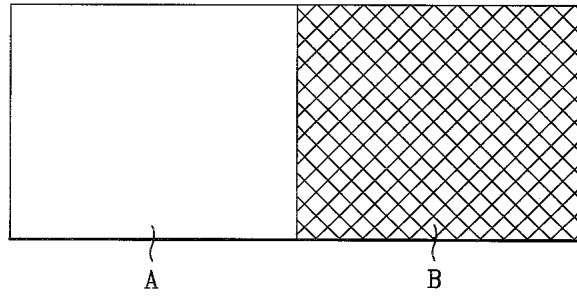

9

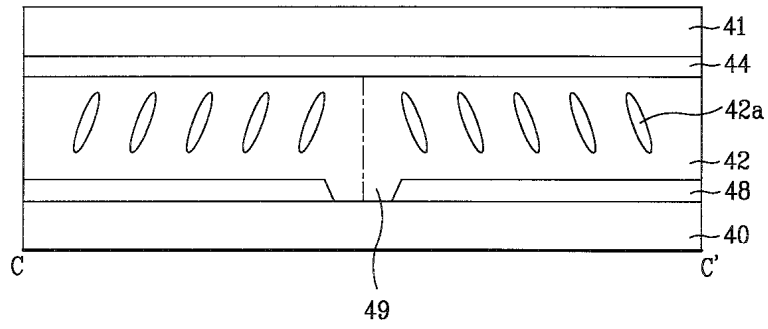

10

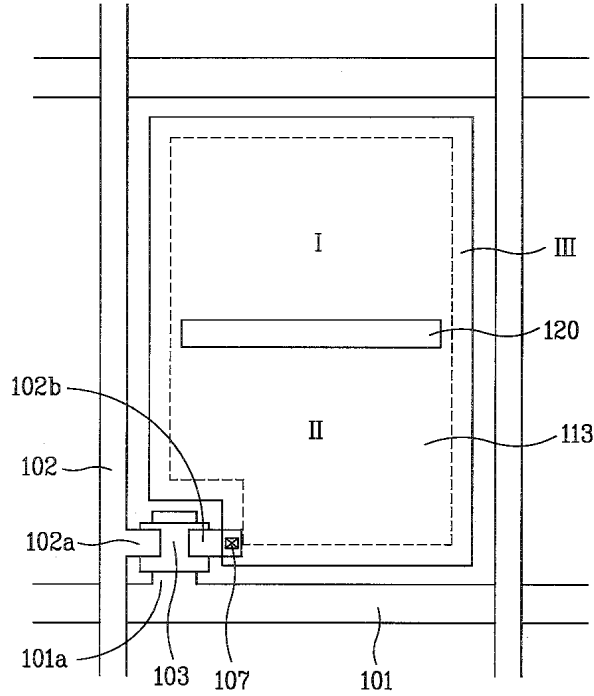

11a

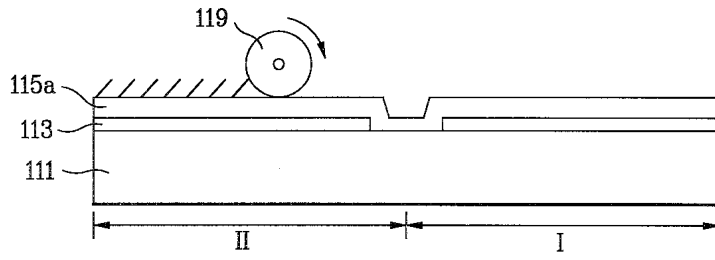

11b

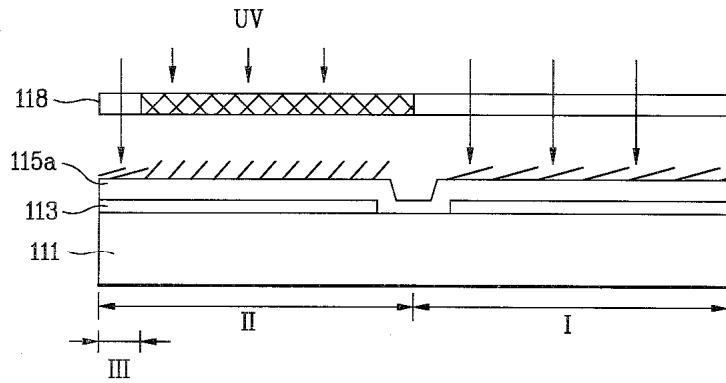

11c

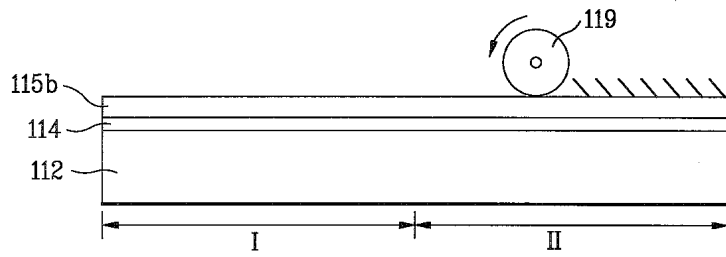

11d

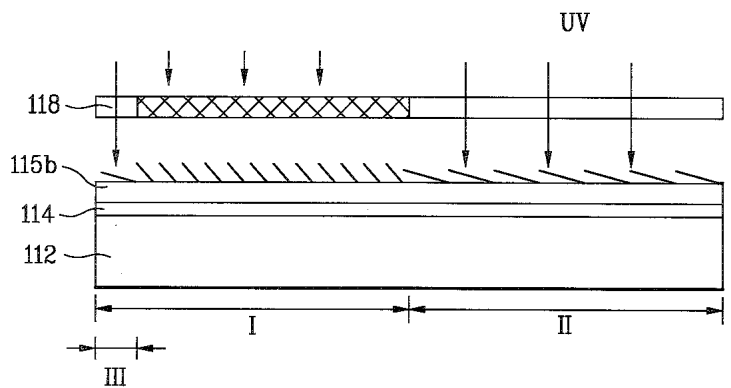

11e

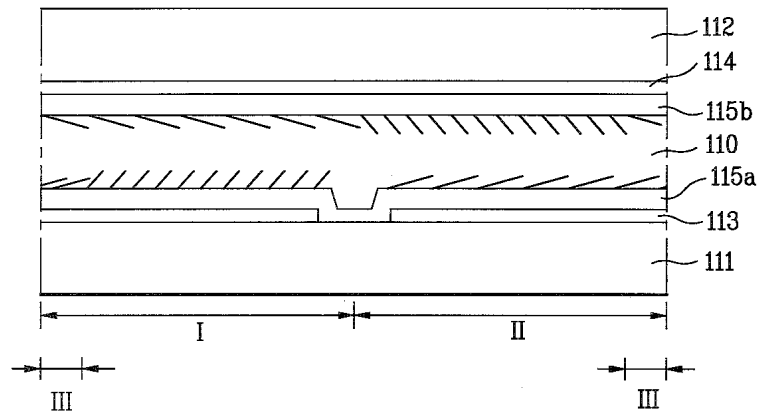

12

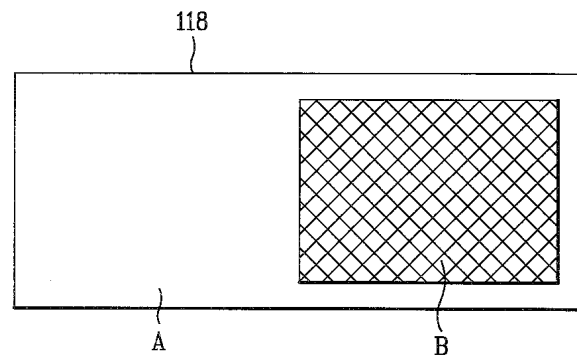

13

