



US009519526B2

(12) **United States Patent**  
**Ghods et al.**

(10) **Patent No.:** **US 9,519,526 B2**  
(45) **Date of Patent:** **\*Dec. 13, 2016**

(54) **FILE MANAGEMENT SYSTEM AND COLLABORATION SERVICE AND INTEGRATION CAPABILITIES WITH THIRD PARTY APPLICATIONS**

(71) Applicant: **Box, Inc.**, Redwood City, CA (US)

(72) Inventors: **Sam Ghods**, San Francisco, CA (US);  
**Florian Jourda**, San Francisco, CA (US); **Aaron Levie**, Palo Alto, CA (US)

(73) Assignee: **Box, Inc.**, Redwood City, CA (US)

(\* ) Notice: Subject to any disclaimer, the term of this patent is extended or adjusted under 35 U.S.C. 154(b) by 122 days.  
  
This patent is subject to a terminal disclaimer.

(21) Appl. No.: **13/646,339**

(22) Filed: **Oct. 5, 2012**

(65) **Prior Publication Data**  
US 2013/0031147 A1 Jan. 31, 2013

**Related U.S. Application Data**  
(63) Continuation of application No. 12/260,533, filed on Oct. 29, 2008, now Pat. No. 8,326,814.  
(Continued)

(51) **Int. Cl.**  
**G06F 17/30** (2006.01)  
**G06F 9/54** (2006.01)

(52) **U.S. Cl.**  
CPC ..... **G06F 9/541** (2013.01)

(58) **Field of Classification Search**  
USPC ..... 707/2, 3, 104.1; 709/227; 711/100  
See application file for complete search history.

(56) **References Cited**

U.S. PATENT DOCUMENTS

5,787,175 A	7/1998	Carter	
5,799,320 A	8/1998	Klug	
5,848,415 A	12/1998	Guck	
5,864,870 A	1/1999	Guck	
5,999,908 A	12/1999	Abelow	
6,016,467 A *	1/2000	Newsted et al. ....	704/9
6,034,621 A	3/2000	Kaufman	
6,055,543 A	4/2000	Christensen et al.	
6,073,161 A	6/2000	DeBoskey et al.	
6,098,078 A	8/2000	Gehani et al.	

(Continued)

FOREIGN PATENT DOCUMENTS

CA	2724521	11/2009
CN	101997924 A	3/2011

(Continued)

OTHER PUBLICATIONS

"PaperPort Professional 14," PC Mag. Com review, published Feb. 2012, Ziff Davis, Inc., 8 pages.

(Continued)

*Primary Examiner* — Etienne Leroux  
(74) *Attorney, Agent, or Firm* — Perkins Coie LLP

(57) **ABSTRACT**

A system and method for providing a file management service for collaboration is disclosed. The method for providing a file management service for collaboration, which may be implemented on a system, includes, for example, providing a client through which a user accesses a file through the file management service, further providing, by the file management service via the client, the user with collaboration capability of the file with other users, and/or controlling editing of the file by other users based on whether it is specified as being shared by the user. In one embodiment, the file management service further enables integration of a third-party service with the file management service and the third-party service is accessible for use with the file via the file management service.

**18 Claims, 11 Drawing Sheets**

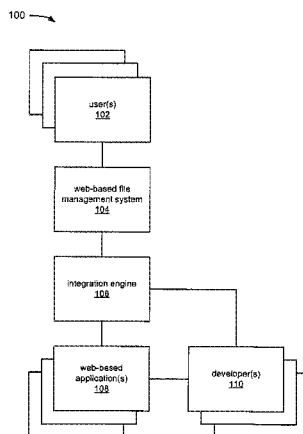

**Related U.S. Application Data**

(60) Provisional application No. 60/992,656, filed on Dec. 5, 2007, provisional application No. 61/055,901, filed on May 23, 2008.

**References Cited**

(56)

U.S. PATENT DOCUMENTS

6,233,600 B1	5/2001	Salas et al.	8,140,513 B2	3/2012	Ghods et al.
6,260,040 B1*	7/2001	Kauffman ..... G06F 17/30067	8,151,183 B2	4/2012	Chen et al.
6,289,345 B1	9/2001	Yasue	8,179,445 B2	5/2012	Hao
6,292,803 B1	9/2001	Richardson et al.	8,214,747 B1	7/2012	Yankovich et al.
6,336,124 B1	1/2002	Alam et al.	8,230,348 B2	7/2012	Peters et al.
6,342,906 B1	1/2002	Kumar et al.	8,326,814 B2	12/2012	Ghods et al.
6,345,386 B1	2/2002	Delo et al.	8,347,276 B2	1/2013	Schadow
6,370,543 B2	4/2002	Hoffert et al.	8,358,701 B2	1/2013	Chou et al.
6,374,260 B1	4/2002	Hoffert et al.	8,370,803 B1	2/2013	Holler et al.
6,385,606 B2	5/2002	Inohara et al.	8,429,540 B1	4/2013	Yankovich et al.
6,396,593 B1	5/2002	Laverty et al.	8,464,161 B2	6/2013	Giles et al.
6,515,681 B1	2/2003	Knight	8,515,902 B2	8/2013	Savage
6,539,381 B1	3/2003	Prasad et al.	8,527,549 B2	9/2013	Cidon
6,584,466 B1*	6/2003	Serbinis et al. .... 715/209	8,549,066 B1	10/2013	Donahue et al.
6,636,872 B1	10/2003	Heath et al.	8,549,511 B2	10/2013	Seki et al.
6,654,737 B1	11/2003	Nunez	8,583,619 B2	11/2013	Ghods et al.
6,662,186 B1	12/2003	Esquibel et al.	8,607,306 B1	12/2013	Bridge et al.
6,687,878 B1	2/2004	Eintracht et al.	8,719,445 B2	5/2014	Ko
6,714,968 B1	3/2004	Prust	8,745,267 B2	6/2014	Luecke et al.
6,735,623 B1	5/2004	Prust	8,849,955 B2	9/2014	Prahlad et al.
6,742,181 B1	5/2004	Koike et al.	8,868,574 B2	10/2014	Kiang et al.
6,760,721 B1	7/2004	Chasen et al.	8,892,679 B1	11/2014	Destagnol et al.
6,947,162 B2	9/2005	Rosenberg et al.	8,914,900 B2	12/2014	Smith et al.
6,952,724 B2	10/2005	Prust	2001/0027492 A1	10/2001	Gupta
6,996,768 B1	2/2006	Elo et al.	2002/0029218 A1	3/2002	Bentley et al.
7,010,752 B2	3/2006	Ly	2002/0091738 A1	7/2002	Rohrbaugh et al.
7,020,697 B1	3/2006	Goodman et al.	2002/0099772 A1	7/2002	Deshpande et al.
7,039,806 B1	5/2006	Friedman et al.	2002/0116544 A1*	8/2002	Barnard et al. .... 709/324
7,069,393 B2	6/2006	Miyata et al.	2002/0133509 A1	9/2002	Johnston et al.
7,130,831 B2	10/2006	Howard et al.	2002/0147770 A1	10/2002	Tang
7,133,834 B1	11/2006	Abelow	2002/0194177 A1	12/2002	Sherman et al.
7,149,787 B1	12/2006	Mutalik et al.	2003/0041095 A1	2/2003	Konda et al.
7,155,483 B1	12/2006	Friend et al.	2003/0084306 A1	5/2003	Abhuri et al.
7,165,107 B2	1/2007	Pouyoul et al.	2003/0093404 A1	5/2003	Bader et al.
7,222,078 B2	5/2007	Abelow	2003/0108052 A1	6/2003	Inoue et al.
7,275,244 B1	9/2007	Bell et al.	2003/0110264 A1	6/2003	Whidby et al.
7,296,025 B2	11/2007	Kung et al.	2003/0115326 A1*	6/2003	Verma et al. .... 709/225
7,346,778 B1	3/2008	Guitar et al.	2003/0135536 A1	7/2003	Lyons
7,353,252 B1	4/2008	Yang et al.	2003/0135565 A1	7/2003	Estrada
7,370,269 B1	5/2008	Prabhu et al.	2003/0154306 A1	8/2003	Perry
7,386,535 B1	6/2008	Kalucha et al.	2003/0204490 A1	10/2003	Kasriel
7,401,117 B2	7/2008	Dan et al.	2003/0217171 A1	11/2003	Von Stuermer et al.
7,523,486 B1*	4/2009	Turner ..... G06F 21/604 707/999.009	2004/0021686 A1	2/2004	Barberis
7,543,000 B2	6/2009	Castro et al.	2004/0088647 A1	5/2004	Miller et al.
7,581,221 B2	8/2009	Lai et al.	2004/0111415 A1	6/2004	Scardino et al.
7,620,565 B2	11/2009	Abelow	2004/0117438 A1	6/2004	Considine et al.
7,647,559 B2	1/2010	Yozell-Epstein et al.	2004/0122949 A1	6/2004	Zmudzinski et al.
7,661,088 B2	2/2010	Burke	2004/0128359 A1	7/2004	Horvitz et al.
7,665,093 B2	2/2010	Maybee et al.	2004/0177138 A1	9/2004	Salle et al.
7,676,542 B2	3/2010	Moser et al.	2004/0181579 A1	9/2004	Huck et al.
7,698,363 B2	4/2010	Dan et al.	2004/0196307 A1	10/2004	Zak et al.
7,734,600 B1	6/2010	Wise et al.	2004/0201604 A1	10/2004	Kraenzel et al.
7,756,843 B1	7/2010	Palmer	2004/0230624 A1	11/2004	Frolund et al.
7,774,412 B1	8/2010	Schnepel	2004/0246532 A1*	12/2004	Inada ..... 358/402
7,814,426 B2	10/2010	Huesken et al.	2004/0267836 A1	12/2004	Armangau et al.
7,886,287 B1	2/2011	Davda	2005/0005276 A1	1/2005	Morgan
7,890,964 B2	2/2011	Vogler-Ivashchanka et al.	2005/0010860 A1	1/2005	Weiss et al.
7,937,663 B2	5/2011	Parker et al.	2005/0028006 A1	2/2005	Leser et al.
7,958,453 B1	6/2011	Taing	2005/0033602 A1*	2/2005	Cirinna et al. .... 705/1
7,979,296 B2	7/2011	Kruse et al.	2005/0050228 A1	3/2005	Perham et al.
7,996,374 B1	8/2011	Jones et al.	2005/0063083 A1	3/2005	Dart et al.
8,027,976 B1	9/2011	Ding et al.	2005/0097225 A1	5/2005	Glatt et al.
RE42,904 E	11/2011	Stephens, Jr.	2005/0102328 A1	5/2005	Ring et al.
8,065,739 B1	11/2011	Bruening et al.	2005/0108406 A1	5/2005	Lee et al.
8,090,361 B2	1/2012	Hagan	2005/0114305 A1	5/2005	Haynes et al.
8,103,662 B2	1/2012	Eagan et al.	2005/0114378 A1	5/2005	Elien et al.
8,117,261 B2	2/2012	Briere et al.	2005/0138118 A1	6/2005	Banatwala et al.
			2005/0182966 A1	8/2005	Pham et al.
			2005/0198299 A1	9/2005	Beck et al.
			2005/0198452 A1	9/2005	Watanabe
			2005/0234864 A1	10/2005	Shapiro
			2005/0234943 A1	10/2005	Clarke
			2005/0246637 A1*	11/2005	Knight ..... G06N 5/025 715/700
			2006/0005163 A1	1/2006	Huesken et al.
			2006/0026502 A1	2/2006	Dutta
			2006/0026535 A1	2/2006	Hotelling et al.
			2006/0036568 A1	2/2006	Moore et al.
			2006/0041603 A1	2/2006	Paterson et al.

(56)

References Cited

U.S. PATENT DOCUMENTS

2006/0047804 A1	3/2006	Fredricksen et al.	2009/0030710 A1	1/2009	Levine
2006/0053088 A1	3/2006	Ali et al.	2009/0044128 A1	2/2009	Baumgarten et al.
2006/0053380 A1	3/2006	Spataro et al.	2009/0049131 A1	2/2009	Lyle et al.
2006/0070083 A1	3/2006	Brunswick et al.	2009/0119322 A1	5/2009	Mills et al.
2006/0075071 A1	4/2006	Gillette	2009/0125469 A1	5/2009	McDonald et al.
2006/0117247 A1	6/2006	Fite et al.	2009/0132651 A1	5/2009	Roger et al.
2006/0123062 A1	6/2006	Bobbitt et al.	2009/0138808 A1	5/2009	Moromisato et al.
2006/0133340 A1	6/2006	Rybak et al.	2009/0150417 A1	6/2009	Ghods et al.
2006/0168550 A1	7/2006	Muller et al.	2009/0158142 A1	6/2009	Arthursson et al.
2006/0174051 A1	8/2006	Lordi et al.	2009/0164438 A1	6/2009	Delacruz
2006/0174054 A1 *	8/2006	Matsuki ..... 711/100	2009/0171983 A1	7/2009	Samji et al.
2006/0179070 A1	8/2006	George et al.	2009/0193107 A1	7/2009	Srinivasan et al.
2006/0242204 A1	10/2006	Karas et al.	2009/0193345 A1	7/2009	Wensley et al.
2006/0259524 A1	11/2006	Horton	2009/0198772 A1	8/2009	Kim et al.
2006/0265719 A1	11/2006	Astl et al.	2009/0210459 A1	8/2009	Nair et al.
2006/0271510 A1	11/2006	Harward et al.	2009/0214115 A1	8/2009	Kimura et al.
2007/0016680 A1 *	1/2007	Burd et al. .... 709/227	2009/0235167 A1	9/2009	Boyer et al.
2007/0038934 A1	2/2007	Fellman	2009/0235181 A1	9/2009	Saliba et al.
2007/0079242 A1	4/2007	Jolley et al.	2009/0235189 A1	9/2009	Aybes et al.
2007/0100830 A1	5/2007	Beedubail et al.	2009/0249224 A1	10/2009	Davis et al.
2007/0115845 A1	5/2007	Hochwarth et al.	2009/0254589 A1	10/2009	Nair et al.
2007/0118598 A1	5/2007	Bedi et al.	2009/0260060 A1	10/2009	Smith et al.
2007/0124460 A1	5/2007	McMullen et al.	2009/0265430 A1	10/2009	Bechtel et al.
2007/0124737 A1	5/2007	Wensley et al.	2009/0271708 A1	10/2009	Peters et al.
2007/0124781 A1	5/2007	Casey et al.	2009/0276771 A1	11/2009	Nickolov et al.
2007/0126635 A1	6/2007	Houri	2009/0282212 A1	11/2009	Peterson
2007/0130143 A1 *	6/2007	Zhang ..... G06F 17/30893	2009/0300356 A1	12/2009	Crandell
2007/0130163 A1	6/2007	Perez et al.	2009/0300527 A1	12/2009	Malcolm et al.
2007/0198609 A1	8/2007	Black et al.	2009/0327358 A1	12/2009	Lukiyanov et al.
2007/0208878 A1	9/2007	Barnes-Leon et al.	2009/0327961 A1	12/2009	De Vorchik et al.
2007/0214180 A1 *	9/2007	Crawford ..... 707/104.1	2010/0011292 A1	1/2010	Marinkovich et al.
2007/0220016 A1	9/2007	Estrada et al.	2010/0011447 A1	1/2010	Jothimani
2007/0220590 A1	9/2007	Rasmussen et al.	2010/0017262 A1	1/2010	Iyer et al.
2007/0240057 A1	10/2007	Satterfield et al.	2010/0036929 A1	2/2010	Scherpa et al.
2007/0250762 A1	10/2007	Mansfield	2010/0042720 A1	2/2010	Stienhans et al.
2007/0256065 A1	11/2007	Heishi et al.	2010/0057560 A1	3/2010	Skudlark et al.
2007/0266304 A1	11/2007	Fletcher et al.	2010/0057785 A1	3/2010	Khosravy et al.
2007/0282848 A1	12/2007	Kuilerich et al.	2010/0076946 A1	3/2010	Barker et al.
2007/0283443 A1	12/2007	McPherson et al.	2010/0082634 A1	4/2010	Leban
2007/0288290 A1	12/2007	Motoyama et al.	2010/0083136 A1	4/2010	Komine et al.
2008/0005135 A1	1/2008	Muthukrishnan et al.	2010/0088150 A1	4/2010	Mazhar et al.
2008/0005195 A1	1/2008	Li	2010/0092126 A1	4/2010	Kaliszek et al.
2008/0021959 A1	1/2008	Naghi et al.	2010/0093310 A1	4/2010	Gbadegesin et al.
2008/0028323 A1	1/2008	Rosen et al.	2010/0107225 A1	4/2010	Spencer et al.
2008/0040173 A1	2/2008	Aleong et al.	2010/0131868 A1	5/2010	Chawla et al.
2008/0040503 A1	2/2008	Kleks et al.	2010/0151431 A1	6/2010	Miller
2008/0046828 A1	2/2008	Bibliowicz et al.	2010/0153835 A1	6/2010	Xiong et al.
2008/0059656 A1	3/2008	Saliba et al.	2010/0162365 A1	6/2010	Del Real
2008/0063210 A1	3/2008	Goodman et al.	2010/0162374 A1	6/2010	Nair
2008/0065881 A1	3/2008	Dawson et al.	2010/0185463 A1	7/2010	Noland et al.
2008/0077631 A1	3/2008	Petri	2010/0185932 A1	7/2010	Coffman et al.
2008/0091763 A1	4/2008	Devonshire et al.	2010/0191689 A1	7/2010	Cortes et al.
2008/0091790 A1 *	4/2008	Beck ..... 709/217	2010/0198783 A1	8/2010	Wang et al.
2008/0104277 A1	5/2008	Tian	2010/0198871 A1	8/2010	Stiegler et al.
2008/0114720 A1	5/2008	Smith et al.	2010/0198944 A1	8/2010	Ho et al.
2008/0133674 A1	6/2008	Knauerhase et al.	2010/0205537 A1	8/2010	Knighton et al.
2008/0140732 A1	6/2008	Wilson et al.	2010/0218237 A1	8/2010	Ferris et al.
2008/0147790 A1	6/2008	Malaney et al.	2010/0223378 A1	9/2010	Wei
2008/0151817 A1	6/2008	Fitchett et al.	2010/0229085 A1	9/2010	Nelson et al.
2008/0182628 A1	7/2008	Lee et al.	2010/0235526 A1	9/2010	Carter et al.
2008/0183467 A1	7/2008	Yuan et al.	2010/0235539 A1	9/2010	Carter et al.
2008/0184130 A1	7/2008	Tien et al.	2010/0241611 A1	9/2010	Zuber
2008/0194239 A1	8/2008	Hagan	2010/0241972 A1	9/2010	Spataro et al.
2008/0215883 A1	9/2008	Fok et al.	2010/0250120 A1	9/2010	Waupotitsch et al.
2008/0222654 A1	9/2008	Xu et al.	2010/0251340 A1	9/2010	Martin et al.
2008/0243855 A1	10/2008	Prahlad et al.	2010/0257457 A1	10/2010	De Goes
2008/0250333 A1	10/2008	Reeves et al.	2010/0262582 A1	10/2010	Garcia-Ascanio et al.
2008/0250348 A1	10/2008	Alimpich et al.	2010/0267588 A1	10/2010	Nelson et al.
2008/0263099 A1	10/2008	Brady-Kalnay et al.	2010/0274765 A1	10/2010	Murphy et al.
2008/0271095 A1	10/2008	Shafton	2010/0274772 A1	10/2010	Samuels
2008/0276158 A1	11/2008	Lim et al.	2010/0281118 A1	11/2010	Donahue et al.
2008/0294899 A1	11/2008	Gazzetta et al.	2010/0290623 A1	11/2010	Banks et al.
2009/0015864 A1	1/2009	Hasegawa	2010/0306379 A1	12/2010	Ferris
2009/0019093 A1	1/2009	Brodersen et al.	2010/0318893 A1	12/2010	Matthews et al.
2009/0019426 A1	1/2009	Baeumer et al.	2010/0322252 A1	12/2010	Suganthi et al.
			2010/0325155 A1	12/2010	Skinner et al.
			2010/0325527 A1	12/2010	Estrada et al.
			2010/0325559 A1	12/2010	Westerinen et al.
			2010/0325655 A1	12/2010	Perez

(56)

References Cited

U.S. PATENT DOCUMENTS

2010/0332401 A1 12/2010 Prahlad et al.  
 2010/0332962 A1 12/2010 Hammer et al.  
 2010/0333116 A1 12/2010 Prahlad et al.  
 2011/0001763 A1 1/2011 Murakami  
 2011/0016409 A1 1/2011 Grosz et al.  
 2011/0022559 A1 1/2011 Andersen et al.  
 2011/0029883 A1 2/2011 Lussier et al.  
 2011/0040812 A1 2/2011 Phillips  
 2011/0041083 A1 2/2011 Gabai et al.  
 2011/0047413 A1 2/2011 McGill et al.  
 2011/0047484 A1 2/2011 Mount et al.  
 2011/0052155 A1 3/2011 Desmarais et al.  
 2011/0054968 A1 3/2011 Galaviz  
 2011/0055299 A1 3/2011 Phillips  
 2011/0055721 A1 3/2011 Jain et al.  
 2011/0061045 A1 3/2011 Phillips  
 2011/0061046 A1 3/2011 Phillips  
 2011/0065082 A1 3/2011 Gal et al.  
 2011/0066951 A1 3/2011 Ward-Karet et al.  
 2011/0093567 A1 4/2011 Jeon et al.  
 2011/0099006 A1 4/2011 Sundararaman et al.  
 2011/0107205 A1 5/2011 Chow et al.  
 2011/0113320 A1 5/2011 Neff et al.  
 2011/0119313 A1 5/2011 Sung et al.  
 2011/0137991 A1 6/2011 Russell  
 2011/0142410 A1 6/2011 Ishii  
 2011/0145744 A1 6/2011 Haynes et al.  
 2011/0161289 A1 6/2011 Pei et al.  
 2011/0167125 A1 7/2011 Achlioptas  
 2011/0167353 A1 7/2011 Grosz et al.  
 2011/0185292 A1 7/2011 Chawla et al.  
 2011/0202424 A1 8/2011 Chun et al.  
 2011/0202599 A1 8/2011 Yuan et al.  
 2011/0209064 A1 8/2011 Jorgensen et al.  
 2011/0219419 A1 9/2011 Reisman  
 2011/0225417 A1 9/2011 Maharajh et al.  
 2011/0238458 A1 9/2011 Purcell et al.  
 2011/0238621 A1 9/2011 Agrawal  
 2011/0238759 A1 9/2011 Spataro et al.  
 2011/0239135 A1 9/2011 Spataro et al.  
 2011/0246294 A1 10/2011 Robb et al.  
 2011/0246950 A1 10/2011 Luna et al.  
 2011/0252071 A1 10/2011 Cidon  
 2011/0252320 A1 10/2011 Arrasvuori et al.  
 2011/0252339 A1 10/2011 Lemonik et al.  
 2011/0258461 A1 10/2011 Bates  
 2011/0258561 A1 10/2011 Ladouceur et al.  
 2011/0289433 A1 11/2011 Whalin et al.  
 2011/0313803 A1 12/2011 Friend et al.  
 2011/0320197 A1 12/2011 Conejero et al.  
 2012/0036370 A1 2/2012 Lim et al.  
 2012/0064879 A1 3/2012 Panci  
 2012/0072436 A1 3/2012 Pierre et al.  
 2012/0079095 A1 3/2012 Evans et al.  
 2012/0089659 A1 4/2012 Halevi et al.  
 2012/0092055 A1 4/2012 Peschke et al.  
 2012/0110005 A1 5/2012 Kuo et al.  
 2012/0110436 A1 5/2012 Adler, III et al.  
 2012/0110443 A1 5/2012 Lemonik et al.  
 2012/0117626 A1 5/2012 Yates et al.  
 2012/0124306 A1 5/2012 Abercrombie et al.  
 2012/0124547 A1 5/2012 Halbedel  
 2012/0130900 A1 5/2012 Tang et al.  
 2012/0134491 A1 5/2012 Liu  
 2012/0136936 A1 5/2012 Quintuna  
 2012/0144283 A1 6/2012 Hill et al.  
 2012/0150888 A1 6/2012 Hyatt et al.  
 2012/0151551 A1 6/2012 Readshaw et al.  
 2012/0158908 A1 6/2012 Luna et al.  
 2012/0159178 A1 6/2012 Lin et al.  
 2012/0159310 A1 6/2012 Chang et al.  
 2012/0173625 A1 7/2012 Berger  
 2012/0179981 A1 7/2012 Whalin et al.  
 2012/0185355 A1 7/2012 Kilroy  
 2012/0192055 A1 7/2012 Antebi et al.

2012/0192086 A1 7/2012 Ghods et al.  
 2012/0204032 A1 8/2012 Wilkins et al.  
 2012/0214444 A1 8/2012 McBride et al.  
 2012/0218885 A1 8/2012 Abel et al.  
 2012/0221789 A1 8/2012 Felter  
 2012/0226767 A1 9/2012 Luna et al.  
 2012/0233155 A1 9/2012 Gallmeier et al.  
 2012/0233205 A1 9/2012 McDermott  
 2012/0233543 A1 9/2012 Vagell et al.  
 2012/0240061 A1 9/2012 Hillenius et al.  
 2012/0257249 A1 10/2012 Natarajan  
 2012/0263166 A1 10/2012 Cho et al.  
 2012/0266203 A1 10/2012 Elhadad et al.  
 2012/0284638 A1 11/2012 Cutler et al.  
 2012/0284664 A1 11/2012 Zhao  
 2012/0296790 A1 11/2012 Robb  
 2012/0309540 A1 12/2012 Holme et al.  
 2012/0311157 A1 12/2012 Erickson et al.  
 2012/0317239 A1 12/2012 Mulder et al.  
 2012/0317487 A1 12/2012 Lieb et al.  
 2012/0328259 A1 12/2012 Seibert, Jr. et al.  
 2012/0331177 A1 12/2012 Jensen  
 2012/0331441 A1 12/2012 Adamson  
 2013/0007245 A1 1/2013 Malik et al.  
 2013/0007471 A1 1/2013 Grab et al.  
 2013/0007894 A1 1/2013 Dang et al.  
 2013/0013560 A1 1/2013 Goldberg et al.  
 2013/0014023 A1 1/2013 Lee et al.  
 2013/0042106 A1 2/2013 Persaud et al.  
 2013/0055127 A1 2/2013 Saito et al.  
 2013/0067232 A1 3/2013 Cheung et al.  
 2013/0073403 A1 3/2013 Tuchman et al.  
 2013/0080919 A1 3/2013 Kiang et al.  
 2013/0117337 A1 5/2013 Dunham  
 2013/0117376 A1 5/2013 Filman et al.  
 2013/0124638 A1 5/2013 Barreto et al.  
 2013/0138608 A1 5/2013 Smith  
 2013/0138615 A1 5/2013 Gupta et al.  
 2013/0159411 A1 6/2013 Bowen  
 2013/0163289 A1 6/2013 Kim et al.  
 2013/0167253 A1 6/2013 Seleznev et al.  
 2013/0185347 A1 7/2013 Romano  
 2013/0185558 A1 7/2013 Seibert et al.  
 2013/0191339 A1 7/2013 Haden et al.  
 2013/0198600 A1 8/2013 Lockhart et al.  
 2013/0212486 A1 8/2013 Joshi et al.  
 2013/0218978 A1 8/2013 Weinstein et al.  
 2013/0239049 A1 9/2013 Perrodin et al.  
 2013/0246932 A1 9/2013 Zaveri et al.  
 2013/0262210 A1 10/2013 Savage et al.  
 2013/0262862 A1 10/2013 Hartley  
 2013/0268480 A1 10/2013 Dorman  
 2013/0268491 A1 10/2013 Chung et al.  
 2013/0275398 A1 10/2013 Dorman et al.  
 2013/0275429 A1 10/2013 York et al.  
 2013/0275509 A1 10/2013 Micucci et al.  
 2013/0282830 A1 10/2013 Besen et al.  
 2013/0305039 A1 11/2013 Gauda  
 2013/0326344 A1 12/2013 Masselle et al.  
 2014/0013112 A1 1/2014 Cidon et al.  
 2014/0019497 A1 1/2014 Cidon et al.  
 2014/0019498 A1 1/2014 Cidon et al.  
 2014/0032489 A1 1/2014 Hebbbar et al.  
 2014/0032616 A1 1/2014 Nack  
 2014/0033277 A1 1/2014 Xiao et al.  
 2014/0033291 A1 1/2014 Liu  
 2014/0052939 A1 2/2014 Tseng et al.  
 2014/0068589 A1 3/2014 Barak  
 2014/0150023 A1 5/2014 Gudorf et al.  
 2014/0156373 A1 6/2014 Roberts et al.  
 2014/0172595 A1 6/2014 Beddow et al.

FOREIGN PATENT DOCUMENTS

CN 102264063 A 11/2011  
 EP 0348614 A2 1/1990  
 EP 0921661 A2 6/1999  
 EP 1349088 10/2003  
 EP 1528746 A2 5/2005

(56)

References Cited

FOREIGN PATENT DOCUMENTS

EP	1933242	A1	6/2008
EP	2372574	A1	10/2011
EP	2610776	A2	7/2013
GB	2453924	A	4/2009
GB	2471282	A	12/2010
JP	09-101937		4/1997
JP	11-025059		1/1999
JP	2003273912	A	9/2003
JP	2004310272	A	11/2004
JP	09-269925		10/2007
JP	2008250944	A	10/2008
KR	20020017444	A	3/2002
KR	20040028036	A	4/2004
KR	20050017674		2/2005
KR	20060070306	A	6/2006
KR	20060114871	A	11/2006
KR	20070043353	A	4/2007
KR	20070100477	A	10/2007
KR	20100118836	A	11/2010
KR	20110074096	A	6/2011
KR	20110076831	A	7/2011
WO	WO-0007104	A1	2/2000
WO	WO-0219128	A1	3/2002
WO	WO-2004097681		11/2004
WO	WO-2006028850	A2	3/2006
WO	WO-2007024438	A1	3/2007
WO	WO-2007035637	A2	3/2007
WO	WO-2007113573	A2	10/2007
WO	WO-2008011142	A2	1/2008
WO	WO-2008076520	A2	6/2008
WO	WO-2011109416	A2	9/2011
WO	WO-2012167272	A1	12/2012
WO	WO-2013009328	A2	1/2013
WO	WO-2013013217	A1	1/2013
WO	WO-2013041763	A1	3/2013
WO	WO-2013166520		11/2013

OTHER PUBLICATIONS

“PaperPort,” Wikipedia article (old revision), published May 19, 2012, Wikipedia Foundation, 2 pages.

“Quickoffice Enhances Android Mobile office Application for Improved Productivity on latest Smartphone and Table Devices,” QuickOffice Press Release, Nov. 21, 2011, QuickOffice Inc., 2 pages.

“QuickOffice,” Wikipedia Article (old revision), published May 9, 2012, Wikipedia Foundation, 2 pages.

Exam Report for GB1309209.3, Applicant: Box, Inc. Mailed Oct. 30, 2013, 11 pages.

Exam Report for GB1310666.1, Applicant: Box, Inc. Mailed Aug. 30, 2013, 10 pages.

Exam Report for GB1313559.5, Applicant: Box, Inc., Mailed Aug. 22, 2013, 19 pages.

Exam Report for GB1316532.9, Applicant: Box, Inc. Mailed Oct. 31, 2013, 10 pages.

Exam Report for GB1316533.7, Applicant: Box, Inc. Mailed Oct. 8, 2013, 9 pages.

Gedymin, “Cloud computing with an emphasis on Google App Engine,” Master Final Project, Sep. 2011, 146 pages.

Google Docs, [http://web.archive.org/web/20100413105758/http://en.wikipedia.org/wiki/Google\\_docs](http://web.archive.org/web/20100413105758/http://en.wikipedia.org/wiki/Google_docs), Apr. 13, 2010, 6 pages.

International Search Report and Written Opinion for PCT/US2013/039782, Applicant: Box, Inc., Mailed Aug. 28, 2013, 15 pages.

International Search Report and Written Opinion for PCT/US2011/039126 mailed on Oct. 6, 2011, pp. 1-13.

International Search Report and Written Opinion for PCT/US2011/041308 Mailed Jul. 2, 2012, pp. 1-16.

International Search Report and Written Opinion for PCT/US2011/056472 mailed on Jun. 22, 2012, pp. 1-12.

International Search Report and Written Opinion for PCT/US2011/060875 Mailed Oct. 30, 2012, pp. 1-10.

International Search Report and Written Opinion for PCT/US2008/012973 dated Apr. 30, 2009, pp. 1-3.

Langfeld L. et al., “Microsoft SharePoint 2003 Unleashed,” Chapters 11 and 15, Jun. 2004, pp. 403-404, 557-561, 578-581.

Partial International Search Report for PCT/US2011/041308 dated Feb. 27, 2012, pp. 1-2.

Supplementary European Search Report European Application No. EP 08 85 8563 dated Jun. 20, 2011 pp. 1-5.

Exam Report for EP13168784.0, Applicant: Box, Inc. Mailed Nov. 21, 2013, 7 pages.

Exam Report for EP13185269.1, Applicant: Box, Inc. Mailed Jan. 28, 2013, 7 pages.

Exam Report for GB1311417.8, Applicant: Box, Inc. Mailed Dec. 20, 2013, 5 pages.

Exam Report for GB1312095.1, Applicant: Box, Inc. Mailed Dec. 12, 2013, 7 pages.

Exam Report for GB1312874.9, Applicant: Box, Inc. Mailed Dec. 20, 2013, 11 pages.

Exam Report for GB1314771.5, Applicant: Box, Inc. Mailed Feb. 17, 2014, 7 pages.

Exam Report for GB1316971.9, Applicant: Box, Inc. Mailed Nov. 26, 2013, 10 pages.

Exam Report for GB1317600.3, Applicant: Box, Inc. Mailed Nov. 21, 2013, 8 pages.

Exam Report for GB1318373.6, Applicant: Box, Inc. Mailed Dec. 17, 2013, 4 pages.

Exam Report for GB1320902.8, Applicant: Box, Inc. Mailed Dec. 20, 2013, 4 pages.

International Search Report and Written Opinion for PCT/US2013/034765, Applicant: Box, Inc., Mailed Jan. 20, 2014, 15 pages.

Patent Court Document of Approved Judgment for GB0602349.3 and GB0623571.7; Mar. 3, 2009, 17 pages.

Exam Report for GB1308842.2, Applicant: Box, Inc. Mailed Mar. 10, 2014, 4 pages.

Burns, “Developing Secure Mobile Applications for Android,” Oct. 2008, Version 1.0, 1-28 pages.

Search Report for EP 11729851.3, Applicant: Box, Inc. Mailed Feb. 7, 2014, 9 pages.

Comes, “MediaXchange User’s Manual,” Version 1.15.15, Feb. 1, 2009, pp. 1-90.

“Average Conversion Time for a D60 RAW file?” <http://www.dpreview.com>, Jul. 22, 2002, 4 pages.

Exam Report for GB1312264.3, Applicant: Box, Inc. Mailed Mar. 24, 2014, 7 pages.

Search Report for EP14153783.7, Applicant: Box, Inc. Mailed Mar. 24, 2014, 7 pages.

“Understanding Metadata,” National Information Standards Organization, NISO Press, 2004, 20 pages.

International Search Report and Written Opinion for PCT/US2012/056955, Applicant: Box, Inc., Mailed Mar. 27, 2013, pp. 1-11.

International Search Report and Written Opinion for PCT/US2011/047530, Applicant: Box, Inc., Mailed Mar. 22, 2013, pp. 1-10.

International Search Report and Written Opinion for PCT/US2012/065617, Applicant: Box, Inc., Mailed Mar. 29, 2013, 9 pages.

International Search Report and Written Opinion for PCT/US2012/067126, Applicant: Box, Inc., Mailed Mar. 29, 2013, 10 pages.

International Search Report and Written Opinion for PCT/US2012/063041, Applicant: Box, Inc., Mailed Mar. 29, 2013, 12 pages.

International Search Report and Written Opinion for PCT/US2011/057938, Applicant: Box, Inc., Mailed Mar. 29, 2013, 10 pages.

Parr, “Google Docs Improves Commenting, Adds E-mail Notifications,” Apr. 16, 2011, mashable.com, pp. 1-6.

“Microsoft Office SharePoint 2007 User Guide,” Feb. 16, 2010, pp. 1-48.

Lars, “35 Very Useful Online Tools for Improving your project Management and Team Collaboration,” Apr. 31, 2010, [tripwiremagazine.com](http://tripwiremagazine.com), pp. 1-32.

Internet Forums, [http://web.archive.org/web/20100528195550/http://en.wikipedia.org/wiki/Internet\\_forums](http://web.archive.org/web/20100528195550/http://en.wikipedia.org/wiki/Internet_forums), Wikipedia, May 30, 2010, pp. 1-20.

Yahoo! Groups, [http://web.archive.org/web/20090320101529/http://en.wikipedia.org/wiki/Yahoo!\\_Groups](http://web.archive.org/web/20090320101529/http://en.wikipedia.org/wiki/Yahoo!_Groups), Wikipedia, Mar. 20, 2009, pp. 1-6.

(56)

**References Cited**

## OTHER PUBLICATIONS

- Wiki, <http://web.archive.org/web/20100213004936/http://en.wikipedia.org/wiki/Wiki>, Feb. 13, 2010, pages 1-16.
- Conner, "Google Apps: The Missing Manual," published by O'Reilly Media, May 27, 2008, 24 pages.
- Cisco, "FTP Load Balancing on ACE in Routed Mode Configuration Example," DocWiki, Jun. 2011, 7 pages.
- Palmer, "Load Balancing FTP Servers," BlogNav, Oct. 2008, 2 pages.
- Wayback, "Wayback machine," Wayback, Jun. 1, 2011, 1 page.
- "Conceptboard", One-Step Solution for Online Collaboration, retrieved from websites <http://conceptboard.com> and <https://www.youtube.com/user/ConceptboardApp?feature=watch>, printed on Jun. 13, 2013, 9 pages.
- "How-to Geek, How to Sync Specific Folders With Dropbox," downloaded from the internet <http://www.howtogeek.com>, Apr. 23, 2013, 5 pages.
- Exam Report for EP13158415.3, Applicant: Box, Inc. Mailed Jun. 4, 2013, 8 pages.
- Exam Report for GB1300188.8, Applicant: Box, Inc. Mailed May 31, 2013, 8 pages.
- Exam Report for GB1306011.6, Applicant: Box, Inc. Mailed Apr. 18, 2013, 8 pages.
- International Search Report and Written Opinion for PCT/US2010/070366, Applicant: Box, Inc., Mailed Apr. 24, 2013, 10 pages.
- International Search Report and Written Opinion for PCT/US2013/020267, Applicant: Box, Inc., Mailed May 7, 2013, 10 pages.
- International Search Report and Written Opinion for PCT/US2013/023889, Applicant: Box, Inc., Mailed Jun. 24, 2013, 13 pages.
- International Search Report and Written Opinion for PCT/US2013/029520, Applicant: Box, Inc., Mailed Jun. 26, 2013, 10 pages.
- International Search Report and Written Opinion for PCT/US2013/034662, Applicant: Box, Inc., Mailed May 31, 2013, 10 pages.
- International Search Report and Written Opinion for PCT/US2013/035404, Applicant: Box, Inc., Mailed Jun. 26, 2013, 13 pages.
- "Revolving sync conflicts; frequently asked questions," Microsoft Tech Support, Jul. 16, 2012, retrieved from the Internet: <http://web.archive.org/web/>, 2 pages.
- "Troubleshoot sync problems," Microsoft Tech Support: May 2, 2012, retrieved from the internet, <http://web.Archive.org/web/>, 3 pages.
- "Tulsa TechFest 2012—Agenda," retrieved from the website, <http://web.archive.org/>, Oct. 2, 2012, 2 pages.
- Cohen, "Debating the Definition of Cloud Computing Platforms," retrieved from the internet, <http://forbes.com>, Feb. 3, 2014, 7 pages.
- Delendik, "Evolving with Web Standards—The Story of PDF.JS," retrieved from the internet, <http://people.mozilla.org>, Oct. 12, 2012, 36 pages.
- Delendik, "My PDF.js talk slides from Tulsa TechFest," retrieved from the internet, <http://twitter.com>, Oct. 12, 2012, 2 pages.
- Duffy, "The Best File-Syncing Services," [pcmag.com](http://www.pcmag.com), retrieved from the internet: <http://www.pcmag.com>, Sep. 28, 2012, 7 pages.
- Exam Report for EP13177108.1, Applicant: Box, Inc. Mailed May 26, 2014, 6 pages.
- Exam Report for GB1318792.7, Applicant: Box, Inc. Mailed May 22, 2014, 2 pages.
- John et al., "Always Sync Support Forums—View topic—Allway sync funny behavior," Allway Sync Support Forum at <http://sync-center.com>, Mar. 28, 2011, XP055109680, 2 pages.
- Partial Search Report for EP131832800, Applicant: Box, Inc. Mailed May 8, 2014, 5 pages.
- Pyle et al., "How to enable Event logging for Offline Files (Client Side Caching) in Windows Vista," Feb. 18, 2009, retrieved from the internet: <http://blogs.technet.com>, 3 pages.
- Rao, "Box Acquires Crocodoc to Add HTML5 Document Converter and Sleek Content Viewing Experience to Cloud Storage Platform," retrieved from the internet, <http://techcrunch.com>, May 9, 2013, 8 pages.
- Search Report for EP13187217.8, Applicant: Box, Inc. Mailed Apr. 15, 2014, 12 pages.
- Search Report for EP141509422, Applicant: Box, Inc. Mailed May 8, 2014, 7 pages.
- Search Report for EP14151588.2, Applicant: Box, Inc. Mailed Apr. 15, 2014, 12 pages.
- Sommerer, "Presentable Document Format: Improved On-demand PDF to HTML Conversion," retrieved from the internet, <http://research.microsoft.com>, 8 pages.
- Tulloch et al., "Windows Vista Resource Kit," Apr. 8, 2007, Microsoft Press, XP055113067, 6 pages.
- Walker, "PDF.js project meeting notes," retrieved from the internet, <http://groups.google.com>, May 15, 2014, 1 page.
- Exam Report for GB1410569.6 Applicant: Box, Inc. Mailed Jul. 11, 2014, 9 pages.
- Extended Search Report for EP131832800, Applicant: Box, Inc. Mailed Aug. 25, 2014, 7 pages.
- Extended Search Report for EP141509422, Applicant: Box, Inc. Mailed Aug. 26, 2014, 12 pages.
- Search Report for Ep 13189144.2 Applicant: Box, Inc. Mailed Sep. 1, 2014, 9 pages.
- Exam Report for GB1312874.9 Applicant: Box, Inc. Mailed Sep. 26, 2014, 2 pages.
- Exam Report for GB1415126.0 Applicant: Box, Inc. Mailed Oct. 2, 2014, 8 pages.
- Exam Report for GB1415314.2 Applicant: Box, Inc. Mailed Oct. 7, 2014, 6 pages.
- Exam Report for GB1309209.3 Applicant: Box, Inc. Mailed Oct. 7, 2014, 3 pages.
- Exam Report for GB1315232.7 Applicant: Box, Inc. Mailed Oct. 9, 2014, 5 pages.
- Exam Report for GB1318789.3 Applicant: Box, Inc. Mailed Oct. 30, 2014, 6 pages.
- Microsoft Windows XP Professional Product Documentation: How Inheritance Affects File and Folder Permissions, Apr. 11, 2014, 2 pages.
- Exam Report for GB1317393.5 Applicant: Box, Inc. Mailed Nov. 7, 2014, 6 pages.
- Exam Report for GB1311417.8 Applicant: Box, Inc. Mailed Nov. 7, 2014, 2 pages.
- Exam Report for GB1311421.0 Applicant: Box, Inc. Mailed Nov. 7, 2014, 4 pages.
- Exam Report for GB1316682.2 Applicant: Box, Inc. Mailed Nov. 19, 2014, 6 pages.
- Exam Report for GB1312095.1 Applicant: Box, Inc. Mailed Nov. 19, 2014, 5 pages.
- Exam Report for GB1313559.5 Applicant: Box, Inc. Mailed Nov. 4, 2014, 2 pages.
- User's Guide for SMART Board Software for Windows, published Dec. 2004, 90 pages.
- Zambonini et al., "Automated Measuring of Interaction with User Interfaces," Published as WO2007113573 Oct. 2007, 19 pages.
- Exam Report for GB1309209.3 Applicant: Box, Inc. Mailed Jan. 19, 2015, 6 pages.
- "Agilewords—How to Request Approval," YouTube, <http://www.youtube.com/watch?v=3-Ov3DYNN3Q>, Jan. 31, 2011, 2 page.
- "Agilewords—Features, Powerful Features Yet Simple," Jun. 1, 2011, <http://web.archive.org/web/20110601223756/http://agilewords.com/product/features/>, 3 pages.
- Conner, "Google Apps: The Missing Manual," published by O'Reilly Media, May 27, 2008, 42 pages.
- Exam Report for EP 13177108.1, Applicant: Box, Inc. Mailed Feb. 17, 2015, 6 pages.
- Exam Report for GB1312264.3 Applicant: Box, Inc. Mailed Jan. 30, 2015, 5 pages.
- Exam Report for GB1312874.9 Applicant: Box, Inc. Mailed Feb. 10, 2015, 7 pages.
- Exam Report for GB1316685.5 Applicant: Box, Inc. Mailed Feb. 17, 2015, 5 pages.
- Exam Report for EP 13185269.1, Applicant: Box, Inc. Mailed Feb. 13, 2015, 8 pages.
- U.S. Appl. No. 60/992,656, filed Dec. 5, 2007 Methods and Systems for Open Source Collaboration in an Application Service Provider Environment.

(56)

**References Cited**

## OTHER PUBLICATIONS

U.S. Appl. No. 61/055,901, filed May 23, 2008 Methods and Systems for Open Source Integration.

U.S. Appl. No. 14/073,502, filed Nov. 6, 2013 Methods and Systems for Open Source Collaboration in an Application Service Provider Environment.

U.S. Appl. No. 61/434,810, filed Jan. 20, 2011 Real Time Notifications of Activity and Real-Time Collaboration in a Cloud-Based Environment With Applications in Enterprise Settings.

U.S. Appl. No. 13/152,982, filed Jun. 3, 2011 Real Time Notification of Activities that Occur in a Web-Based Collaboration Environment.

U.S. Appl. No. 13/166,733, filed Jun. 22, 2011 Multimedia Content Preview Rendering in a Cloud Content Management System.

U.S. Appl. No. 61/551,894, filed Oct. 26, 2011 Enhanced Multimedia Content Preview Rendering in a Cloud Content Management System.

U.S. Appl. No. 13/590,012, filed Aug. 20, 2012 Preview Pre-Generation Based on Heuristics and Algorithmic Prediction/Assessment of Predicted User Behavior for Enhancement of User Experience.

U.S. Appl. No. 13/297,230, filed Nov. 15, 2011 Enhanced Multimedia Content Preview Rendering in a Cloud Content Management System.

U.S. Appl. No. 61/592,567, filed Jan. 30, 2012 Preview Pre-Generation Based on Heuristics and Algorithmic Prediction/Assessment of Predicted User Behavior for Enhancement of User Experience.

U.S. Appl. No. 61/506,013, filed Jul. 8, 2011 Collaboration Sessions in a Workspace on a Workspace on a Cloud-Based Content Management System.

U.S. Appl. No. 13/208,615, filed Aug. 12, 2011 Collaboration Sessions in a Workspace on a Cloud-Based Content Management System.

U.S. Appl. No. 61/592,394, filed Jan. 30, 2012 Extended Applications of Multimedia Content Previews in the Cloud-Based Content Management System.

U.S. Appl. No. 13/588,356, filed Aug. 17, 2012 Extended Applications of Multimedia Content Previews in the Cloud-Based Content Management System.

U.S. Appl. No. 13/968,357, filed Aug. 15, 2013 Automatic and Semi-Automatic Tagging Features of Work Items in a Shared Workspace for Metadata Tracking in a Cloud-Based Content Management System With Selective or Optional User Contribution.

U.S. Appl. No. 61/538,782, filed Sep. 23, 2011 Central Management and Control of User-Contributed Content in a Web-Based Collaboration Environment and Management Console Thereof.

U.S. Appl. No. 13/547,264, filed Jul. 12, 2012 Central Management and Control of User-Contributed Content in a Web-Based Collaboration Environment and Management Console Thereof.

U.S. Appl. No. 13/165,725, filed Jun. 21, 2011 Batch Uploading of Content to a Web-Based Collaboration Environment.

U.S. Appl. No. 61/505,999, filed Jul. 11, 2011 Desktop Application for Access and Interaction with Workspaces in a Cloud-Based Content Management System and Synchronization Mechanisms Thereof.

U.S. Appl. No. 13/282,427, filed Oct. 26, 2011 Desktop Application for Access and Interaction with Workspaces in a Cloud-Based Content Management System and Synchronization Mechanisms Thereof.

U.S. Appl. No. 61/554,450, filed Nov. 1, 2011 Platform and Application Independent Method for Document Editing and Version Tracking Via a Web Browser.

U.S. Appl. No. 13/332,319, filed Dec. 20, 2011 Platform and Application Independent System and Method for Networked File Access and Editing.

U.S. Appl. No. 13/414,480, filed Mar. 7, 2012 Universal File Type Preview for Mobile Devices.

U.S. Appl. No. 61/564,425, filed Nov. 29, 2011 Mobile Platform Folder Synchronization and Offline Synchronization.

U.S. Appl. No. 61/568,430, filed Dec. 8, 2011 Mobile Platform File and Folder Selection Functionalities for Offline Access and Synchronization.

U.S. Appl. No. 13/689,544, filed Nov. 29, 2012 Mobile Platform File and Folder Selection Functionalities for Offline Access and Synchronization.

U.S. Appl. No. 13/345,502, filed Jan. 6, 2012 System and Method for Actionable Event Generation for Task Delegation and Management Via a Discussion Forum in a Web-Based Collaboration Environment.

U.S. Appl. No. 13/619,439, filed Sep. 14, 2012 Batching Notifications of Activities That Occur in a Web-Based Collaboration Environment.

U.S. Appl. No. 61/560,685, filed Nov. 16, 2011 Temporal and Spatial Processing and Tracking of Events in a Web-Based Collaboration Environment for Asynchronous Delivery in an Ordered Fashion.

U.S. Appl. No. 13/524,501, filed Jun. 15, 2012 Resource Effective Incremental Updating of a Remote Client With Events Which Occurred Via a Cloud-Enabled Platform.

U.S. Appl. No. 13/526,437, filed Jun. 18, 2012 Managing Updates at Clients Used by a User to Access a Cloud-Based Collaboration Service.

U.S. Appl. No. 61/579,551, filed Dec. 22, 2011 System Status Monitoring and Data Health Checking in a Collaborative Environment.

U.S. Appl. No. 13/464,813, filed Apr. 4, 2012 Health Check Services for Web-Based Collaboration Environments.

U.S. Appl. No. 13/405,164, filed Feb. 24, 2012 System and Method for Promoting Enterprise Adoption of a Web-Based Collaboration Environment.

U.S. Appl. No. 13/431,645, filed Mar. 27, 2012 Cloud Service or Storage Use Promotion Via Partnership Driven Automatic Account Upgrades.

U.S. Appl. No. 61/620,554, filed Apr. 5, 2012 Device Pinning Capability for Enterprise Cloud Service and Storage Accounts.

U.S. Appl. No. 13/493,922, filed Jun. 11, 2012 Device Pinning Capability for Enterprise Cloud Service and Storage Accounts.

U.S. Appl. No. 61/649,869, filed Mar. 21, 2012 Selective Application Access Control Via a Cloud-Based Service for Security Enhancement.

U.S. Appl. No. 13/493,783, filed Jun. 11, 2012 Security Enhancement Through Application Access Control.

U.S. Appl. No. 61/702,948, filed Sep. 19, 2012 Cloud-Based Platform Enabled With Media Content Indexed for Text-Based Searches and/or Metadata Extraction.

U.S. Appl. No. 13/829,663, filed Mar. 14, 2013 Cloud-Based Platform Enabled With Media Content Indexed for Text-Based Searches and/or Metadata Extraction.

U.S. Appl. No. 61/702,662, filed Sep. 18, 2012 Sandboxing Individual Applications to Specific User Folders in a Cloud-Based Service.

U.S. Appl. No. 13/830,016, filed Mar. 14, 2013 Sandboxing Individual Applications to Specific User Folders in a Cloud-Based Service.

U.S. Appl. No. 61/620,568, filed Apr. 5, 2012 Synchronization Client Selective Subfolder Syncing in a Cloud-Based Environment.

U.S. Appl. No. 13/856,607, filed Apr. 4, 2013 Method and Apparatus for Selective Subfolder Synchronization in a Cloud-Based Environment.

U.S. Appl. No. 61/622,868, filed Apr. 11, 2012 Web and Desktop Client Synchronization of Mac Packages With a Cloud-Based Platform.

U.S. Appl. No. 13/618/993, filed Sep. 14, 2012 Cloud Service Enabled to Handle a Set of Files Depicted to a User as a Single File in a Native Operating System.

U.S. Appl. No. 61/643,116, filed May 4, 2012 Hbase Redundancy Implementation for Action Log Framework.

U.S. Appl. No. 13/890,172, filed May 8, 2013 Repository Redundancy Implementation of a System Which Incrementally Updates Clients With Events That Occurred Via a Cloud-Enabled Platform.

(56)

**References Cited**

## OTHER PUBLICATIONS

- U.S. Appl. No. 13/888,308, filed May 6, 2013 Repository Redundancy Implementation of a System Which Incrementally Updates Clients With Events That Occurred Via a Cloud-Enabled Platform.
- U.S. Appl. No. 61/693,521, filed Aug. 27, 2012 Backend Implementation of Synchronization Client Selective Subholder Syncing in a Cloud-Based Environment.
- U.S. Appl. No. 14/010,851, filed Aug. 27, 2013 Server Side Techniques for Reducing Database Workload in Implementing Selective Subfolder Synchronization in a Cloud-Based Environment.
- U.S. Appl. No. 61/641,824, filed May 2, 2012 Platform and Application Agnostic Method for Seamless File Access in a Mobile Environment.
- U.S. Appl. No. 61/650,840, filed May 23, 2012 Platform and Application Agnostic Method for Seamless File Access in a Mobile Environment.
- U.S. Appl. No. 61/653,876, filed May 31, 2012 Platform and Application Agnostic Method for Seamless File Access in a Mobile Environment.
- U.S. Appl. No. 13/886,147, filed May 2, 2013 System and Method for a Third-Party Application to Access Content Within a Cloud-Based Platform.
- U.S. Appl. No. 13/897,421, filed May 19, 2013 Methods, Architectures and Security Mechanisms for a Third-Party Application to Access Content in a Cloud-Based Platform.
- U.S. Appl. No. 13/898,200, filed May 20, 2013 Metadata Enabled Third-Party Application Access of Content at a Cloud-Based Platform Via a Native Client to The Cloud-Based Platform.
- U.S. Appl. No. 13,898,242, filed May 20, 2013 Identification Verification Mechanisms for a Third-Party Application to Access Content in a Cloud-Based Platform.
- U.S. Appl. No. 61/667,909, filed Jul. 3, 2012 Highly Available Ftp Servers for a Cloud-Based Service.
- U.S. Appl. No. 13/565,136, filed Aug. 2, 2012 Load Balancing Secure Ftp Connections Among Multiple Ftp Servers.
- U.S. Appl. No. 13/649,784, (U.S. Pat. No. 8,179,445), Oct. 11, 2012, (May 6, 2014), Highly Available Ftp Servers For A Cloud-Based Service, Hao May 2012.
- U.S. Appl. No. 13/937,060, filed Jul. 8, 2013 System and Method for Performing Shard Migration to Support Functions of a Cloud-Based Service.
- U.S. Appl. No. 61/668,698, filed Jul. 6, 2012 Identification of People as Search Results From Key-Word Based Searches of Content.
- U.S. Appl. No. 13/937,101, filed Jul. 8, 2013 Identification of People as Search Results From Key-Word Based Searches of Content in a Cloud-Based Environment.
- U.S. Appl. No. 61/668,791, filed Jul. 6, 2012 Systems and Methods for Specifying User and Item Identifiers Within an Email Address for Securely Submitting Comments Via Email.
- U.S. Appl. No. 13/937,124, filed Jul. 8, 2013 Systems and Methods for Securely Submitting Comments Among Users Via External Messaging Applications in a Cloud-Based Platform.
- U.S. Appl. No. 61/673,671, filed Jul. 19, 2012 Data Loss Prevention Methods and Architectures in a Cloud Service.
- U.S. Appl. No. 13/944,184, filed Jul. 17, 2013 Data Loss Prevention (Dlp) Methods and Architectures by a Cloud Service.
- U.S. Appl. No. 13/944,241, filed Jul. 17, 2013 Data Loss Prevention (Dlp) Methods by a Cloud Service Including Third Party Integration Architectures.
- U.S. Appl. No. 61/694,492, filed Aug. 29, 2012 Method of Streaming File Encryption and Decryption to/From a Collaborative Cloud.
- U.S. Appl. No. 13/975,827, filed Aug. 26, 2013 Method of Streaming File Encryption and Decryption to/From a Collaborative Cloud.
- U.S. Appl. No. 61/701,823, filed Sep. 17, 2012 Use of a Status Bar Interface Element as a Handle for Revealing Additional Details.
- U.S. Appl. No. 13/737,577, filed Jan. 9, 2013 System and Method of a Manipulative Handle in an Interactive Mobile User Interface.
- U.S. Appl. No. 61/697,437, filed Sep. 6, 2012 Secure File Portability Between Mobile Applications Using a Server-Based Key Generation Service.
- U.S. Appl. No. 13/776,358, filed Feb. 25, 2013 Secure File Portability Between Mobile Applications Using a Server-Based Key Generation Service.
- U.S. Appl. No. 61/697,469, filed Sep. 6, 2012 Force Upgrade of a Mobile Application Via Server Side Configuration Files.
- U.S. Appl. No. 13/776,467, filed Feb. 25, 2013 Force Upgrade of a Mobile Application Via Server Side Configuration Files.
- U.S. Appl. No. 61/697,477, filed Sep. 6, 2012 Disabling the Self-Referential Appearance of a Mobile Application in an Intent Via a Background Registration.
- U.S. Appl. No. 13/794,401, filed Mar. 11, 2013 Disabling the Self-Referential Appearance of a Mobile Application in an Intent Via a Background Registration.
- U.S. Appl. No. 61/697,511, filed Sep. 6, 2012 Channel for Opening and Editing Files from a Cloud Service Provider Based on Intents.
- U.S. Appl. No. 13/776,535, filed Feb. 25, 2013 System and Method for Creating a Secure Channel for Inter-Application Communication Based on Intents.
- U.S. Appl. No. 61/694,466, filed Aug. 12, 2012 Optimizations for Client and/or Server Feedback Information Enabled Real Time or Near Real Time Enhancement of Upload/Download Performance.
- U.S. Appl. No. 61/702,154, filed Sep. 17, 2012 Optimizations for Client and/or Server Feedback Information Enabled Real Time or Near Real Time Enhancement of Upload/Download Performance.
- U.S. Appl. No. 61/703,699, filed Sep. 20, 2012 Optimizations for Client and/or Server Feedback Information Enabled Real Time or Near Real Time Enhancement of Upload/Download Performance.
- U.S. Appl. No. 14/293,685, filed Jun. 2, 2014 Enhancement of Upload and/or Download Performance Based on Client and/or Server Feedback Information.
- U.S. Appl. No. 61/751,578, filed Jan. 11, 2013 Functionalities, Features, and User Interface of a Synchronization Client to a Cloud-Based Environment.
- U.S. Appl. No. 14/153,726, filed Jan. 13, 2014 Functionalities, Features, and User Interface of a Synchronization Client to a Cloud-Based Environment.
- U.S. Appl. No. 61/715,208, filed Oct. 17, 2012 Adaptive Architectures for Encryption Key Management in a Cloud-Based Environment.
- U.S. Appl. No. 14/056,899, filed Oct. 17, 2013 Remote Key Management in a Cloud-Based Environment.
- U.S. Appl. No. 61/709,086, filed Oct. 2, 2012 Visibility, Access Control, Advanced Reporting Api, and Enhanced Data Protection and Security Mechanisms for Administrators in an Enterprise.
- U.S. Appl. No. 14/044,261, filed Oct. 2, 2013 System and Method for Enhanced Security and Management Mechanisms for Enterprise Administrators in a Cloud-Based Environment.
- U.S. Appl. No. 61/709,653, filed Oct. 4, 2012 Corporate User Discovery and Identification of Recommended Collaborators in a Cloud Platform.
- U.S. Appl. No. 14/046,294, filed Oct. 4, 2013 Corporate User Discovery and Identification of Recommended Collaborators in a Cloud Platform.
- U.S. Appl. No. 61/709,866, filed Oct. 4, 2012 Enhanced Quick Search Features, Low-Barrier Commenting/Interactive Features in a Collaboration Platform.
- U.S. Appl. No. 14/046,523, filed Oct. 4, 2013 Enhanced Quick Search Features, Low-Barrier Commenting/Interactive Features in a Collaboration Platform.
- U.S. Appl. No. 61/709,407, filed Oct. 4, 2012 Seamless Access, Editing, and Creation of Files in a Web Interface or Mobile Interface to a Cloud Platform.
- U.S. Appl. No. 14/046,726, filed Oct. 4, 2013 Seamless Access, Editing, and Creation of Files in a Web Interface or Mobile Interface to a Collaborative Cloud Platform.
- U.S. Appl. No. 61/710,182, filed Oct. 5, 2012 Embedded Html Folder Widget for Accessing a Cloud Collaboration Platform and Content From Any Site.

(56)

**References Cited**

## OTHER PUBLICATIONS

U.S. Appl. No. 14/047,223, filed Oct. 7, 2013 System and Method for Generating Embeddable Widgets Which Enable Access to a Cloud-Based Collaboration Platform.

U.S. Appl. No. 61/750,474, filed Jan. 9, 2013 File System Event Monitor and Event Filter Pipeline for a Cloud-Based Platform.

U.S. Appl. No. 14/149,586, filed Jan. 7, 2014 File System in a System Which Incrementally Updates Clients With Events That Occurred in a Cloud-Based Collaboration Platform.

U.S. Appl. No. 61/753,761 Conflict Resolution, Retry Condition Management, and Handling of Problem Files for the Synchronization Client to a Cloud-Based Platform.

U.S. Appl. No. 14/158,626 Conflict Resolution, Retry Condition Management, and Handling of Problem Files for the Synchronization Client to a Cloud-Based Platform.

U.S. Appl. No. 61/739,296, filed Dec. 19, 2012 Synchronization of Read-Only Files/Folders by a Synchronization Client With a Cloud-Based Platform.

U.S. Appl. No. 14/135,311, filed Dec. 19, 2013 Method and Apparatus for Synchronization of Items With Read-Only Permissions in a Cloud-Based Environment.

U.S. Appl. No. 61/748,399, filed Jan. 2, 2013 Handling Action Log Framework Race Conditions for a Synchronization Client to a Cloud-Based Environment.

U.S. Appl. No. 14/146,658, filed Jan. 2, 2014 Race Condition Handling in a System Which Incrementally Updates Clients With Events That Occurred in a Cloud-Based Collaboration Platform.

U.S. Appl. No. 61/822,170, filed May 10, 2013 Identification and Handling of Items to be Ignored for Synchronization With a Cloud-Based Platform by a Synchronization Client.

U.S. Appl. No. 14,275,890, filed May 13, 2014 Identification and Handling of Items to be Ignored for Synchronization With a Cloud-Based Platform by a Synchronization Client.

U.S. Appl. No. 61/822,191, filed May 10, 2013 Systems and Methods for Depicting Item Synchronization With a Cloud-Based Platform by a Synchronization Client.

U.S. Appl. No. 14/275,401, filed May 12, 2014 Top Down Delete or Unsyncronization on Delete of and Depiction of Item Synchronization With a Synchronization Client to a Cloud-Based Platform.

U.S. Appl. No. 61/834,756, filed Jun. 13, 2013 Systems and Methods for Event Building, Collapsing, or Monitoring by a Synchronization Client of a Cloud-Based Platform.

U.S. Appl. No. 14/304,038, filed Jun. 13, 2014 Systems and Methods for Synchronization Event Building and/or Collapsing by a Synchronization Component of a Cloud-Based Platform.

U.S. Appl. No. 61/838,176, filed Jun. 21, 2013 Maintaining and Updating File System Shadows on a Local Device by a Synchronization Client of a Cloud-Based Platform.

U.S. Appl. No. 14/312,482, filed Jun. 23, 2014 Maintaining and Updating File System Shadows on a Local Device by a Synchronization Client of a Cloud-Based Platform.

U.S. Appl. No. 61/839,325, filed Jun. 23, 2013 Systems and Methods for Improving Performance of a Cloud-Based Platform.

U.S. Appl. No. 14/314,887, filed Jun. 25, 2014 Systems and Methods for Managing Upgrades, Migration of User Data and Improving Performance of a Cloud-Based Platform.

U.S. Appl. No. 61/839,331, filed Jun. 25, 2013 Systems and Methods for Providing Shell Communication in a Cloud-Based Platform.

U.S. Appl. No. 14/314,677, filed Jun. 25, 2014 Systems and Methods for Providing Shell Communication in a Cloud-Based Platform.

U.S. Appl. No. 13/954,680, filed Jul. 30, 2013 System and Method for Advanced Control Tools for Administrators in a Cloud-Based Service.

U.S. Appl. No. 61/860,050, filed Jul. 30, 2013 Scalability Improvement in a System Which Incrementally Updates Clients With Events That Occurred in a Cloud-Based Collaboration Platform.

U.S. Appl. No. 14/194,091, filed Feb. 28, 2014 Scalability Improvement in a System Which Incrementally Updates Clients With Events That Occurred in a Cloud-Based Collaboration Platform.

U.S. Appl. No. 13/953,668, filed Jul. 29, 2013 System and Method for Advanced Search and Filtering Mechanisms for Enterprise Administrators in a Cloud-Based Environment.

U.S. Appl. No. 14/026,674, filed Sep. 13, 2013 Configurable Event-Based Automation Architecture for Cloud-Based Collaboration Platforms.

U.S. Appl. No. 61/877,917, filed Sep. 13, 2013 Systems and Methods for Configuring Event-Based Automation in Cloud-Based Collaboration Platforms.

U.S. Appl. No. 14/075,849, filed Nov. 8, 2013 Systems and Methods for Configuring Event-Based Automation in Cloud-Based Collaboration Platforms.

U.S. Appl. No. 14/027,149, filed Sep. 13, 2013 Simultaneous Editing/Accessing of Content by Collaborator Invitation Through a Web-Based or Mobile Application to a Cloud-Based Collaboration Platform.

U.S. Appl. No. 14/042,473, filed Sep. 30, 2013 Simultaneous Editing/Accessing of Content by Collaborator Invitation Through a Web-Based or Mobile Application to a Cloud-Based Collaboration Platform.

U.S. Appl. No. 14/026,837, filed Sep. 13, 2013 Mobile Device, Methods and User Interfaces Thereof in a Mobile Device Platform Featuring Multifunctional Access and Engagement in a Collaborative Environment Provided by a Cloud-Based Platform.

U.S. Appl. No. 14/166,414, filed Jan. 28, 2014 System and Method of a Multi-Functional Managing User Interface for Accessing a Cloud-Based Platform Via Mobile Devices.

U.S. Appl. No. 14/027,147, filed Sep. 13, 2013 System and Method for Rendering Document in Web Browser or Mobile Device Regardless of Third-Party Plug-In Software.

U.S. Appl. No. 61/877,938, filed Sep. 13, 2013 High Availability Architecture for a Cloud-Based Concurrent-Access Collaboration Platform.

U.S. Appl. No. 14/474,507, filed Sep. 2, 2014 High Availability Architecture for a Cloud-Based Concurrent-Access Collaboration Platform.

U.S. Appl. No. 61/894,340, filed Oct. 22, 2013 Desktop Application for Accessing a Cloud Collaboration Platform.

U.S. Appl. No. 14/521,134, filed Oct. 22, 2014 Desktop Application for Accessing a Cloud Collaboration Platform.

U.S. Appl. No. 14/472,540, filed Aug. 29, 2014 Enhanced Remote Key Management for an Enterprise in a Cloud-Based Environment.

U.S. Appl. No. 14/474,008, filed Aug. 28, 2014 Configurable Metadata-Based Automation and Content Classification Architecture for Cloud-Based Collaboration Platforms.

\* cited by examiner

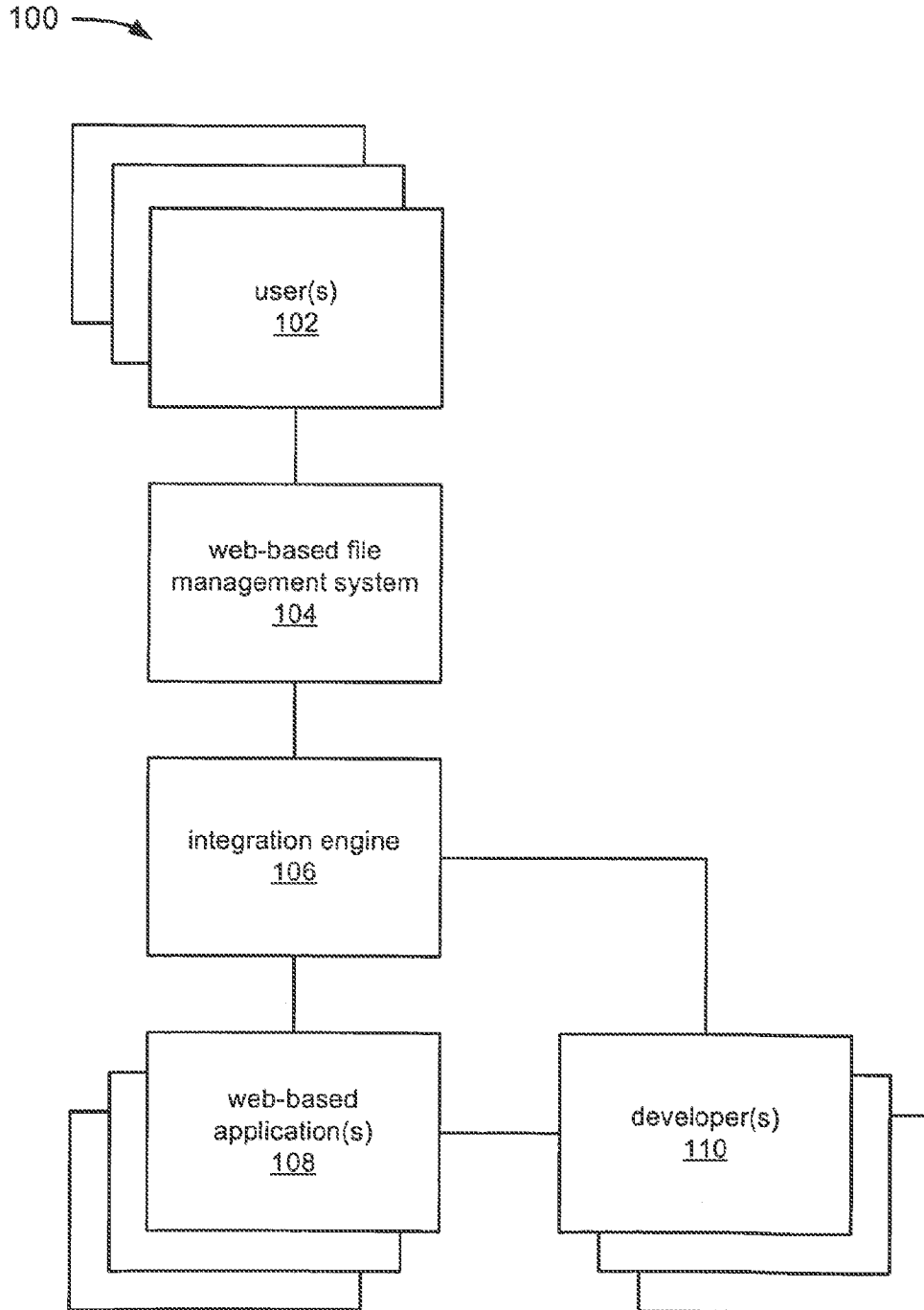

FIG. 1

200 →

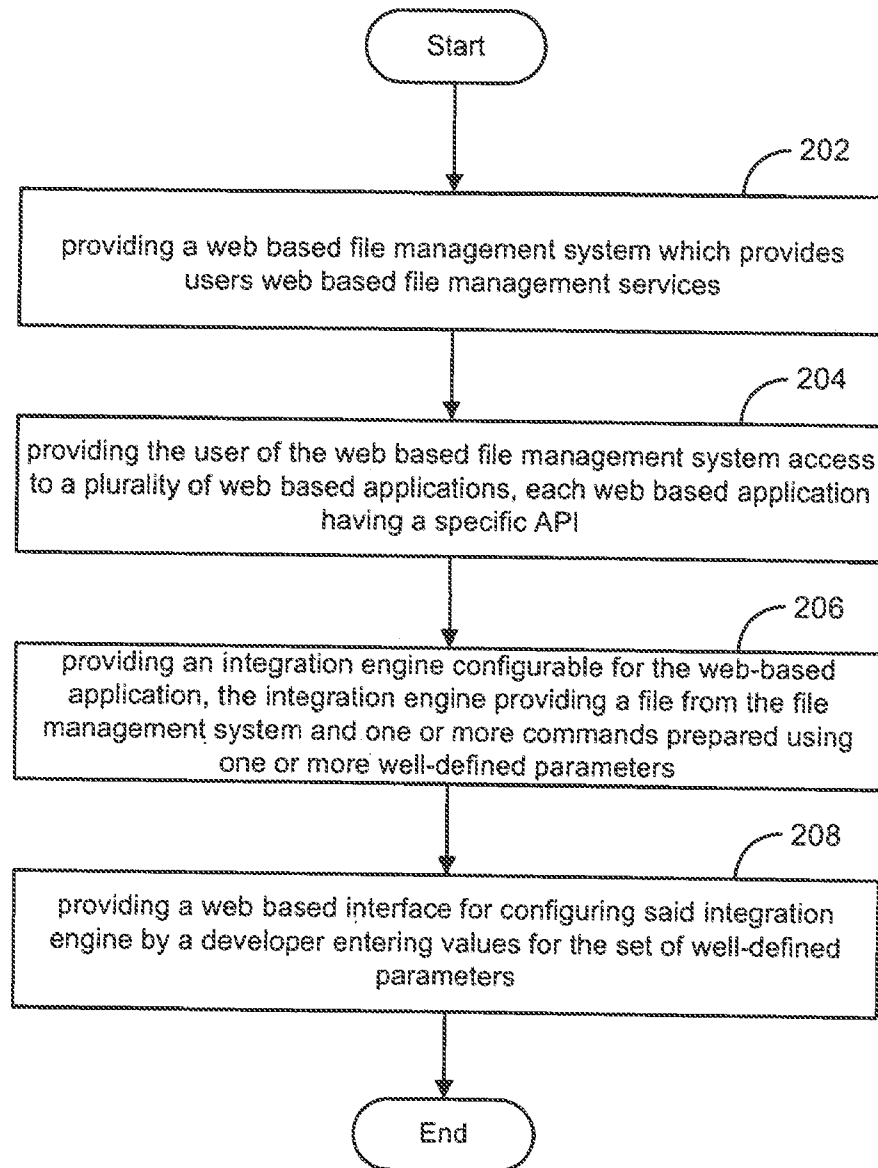

FIG. 2

300 →

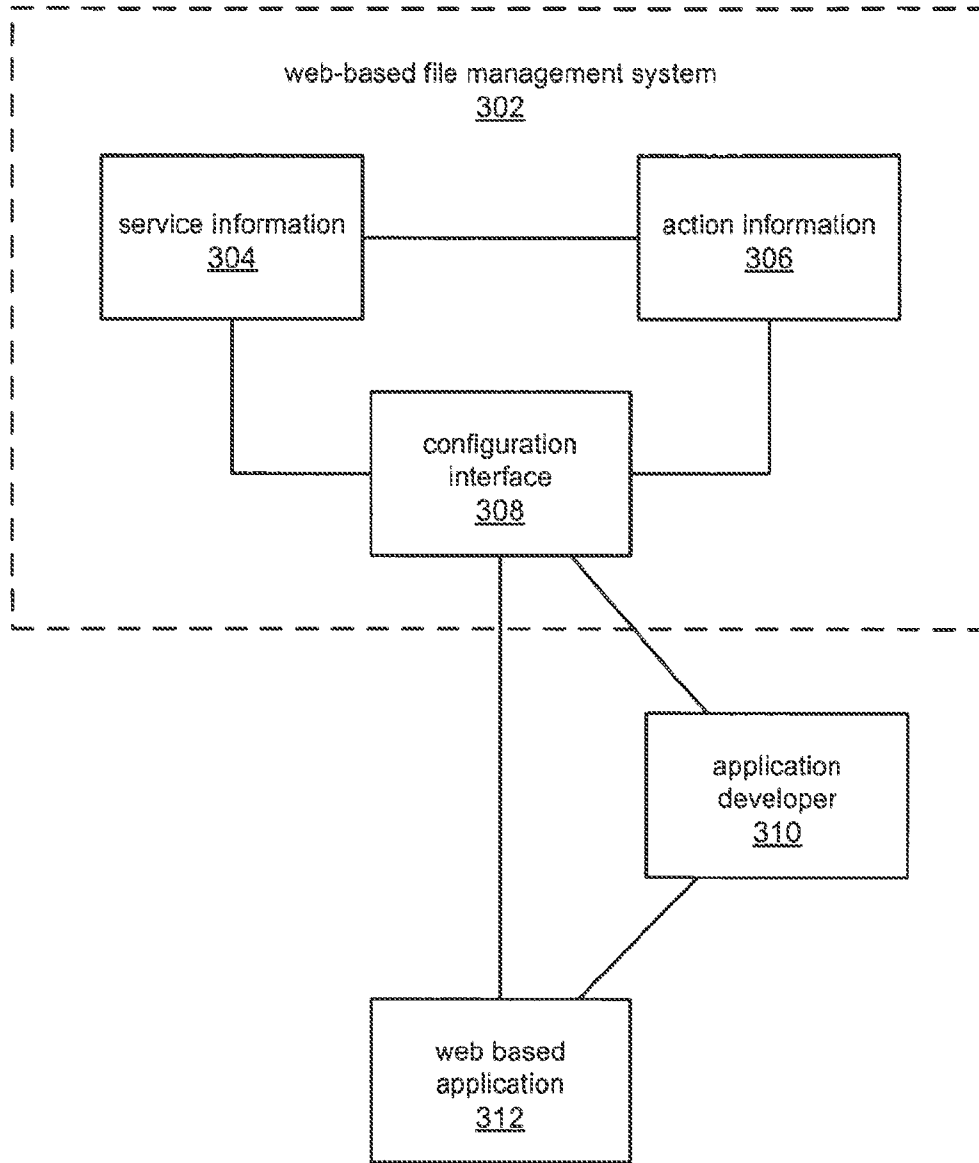

FIG. 3

400 →

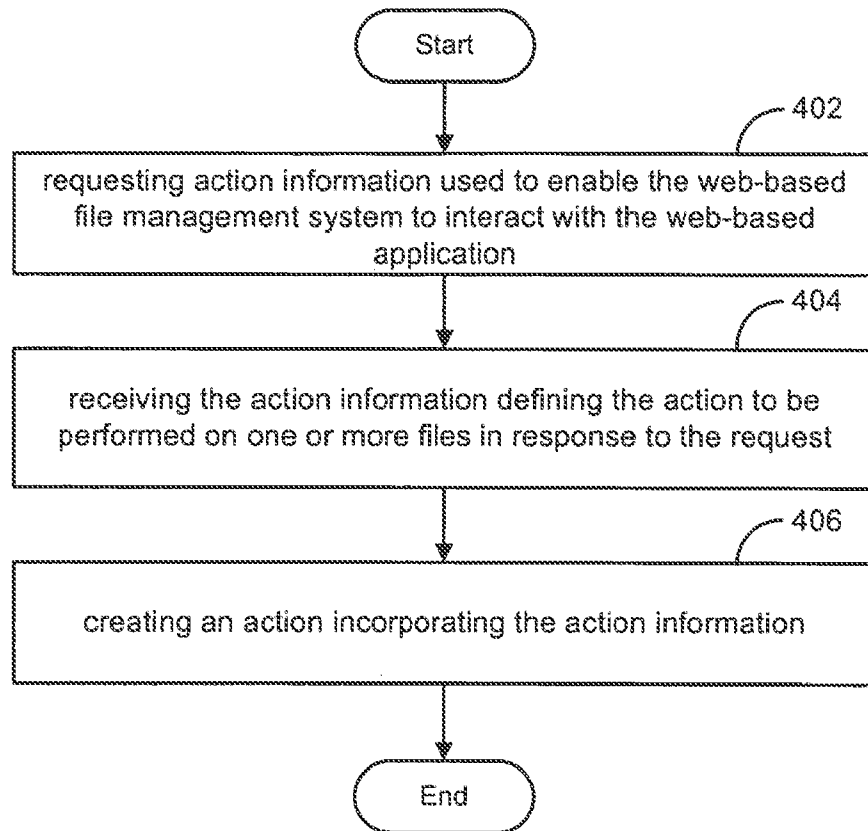

FIG. 4

500 →

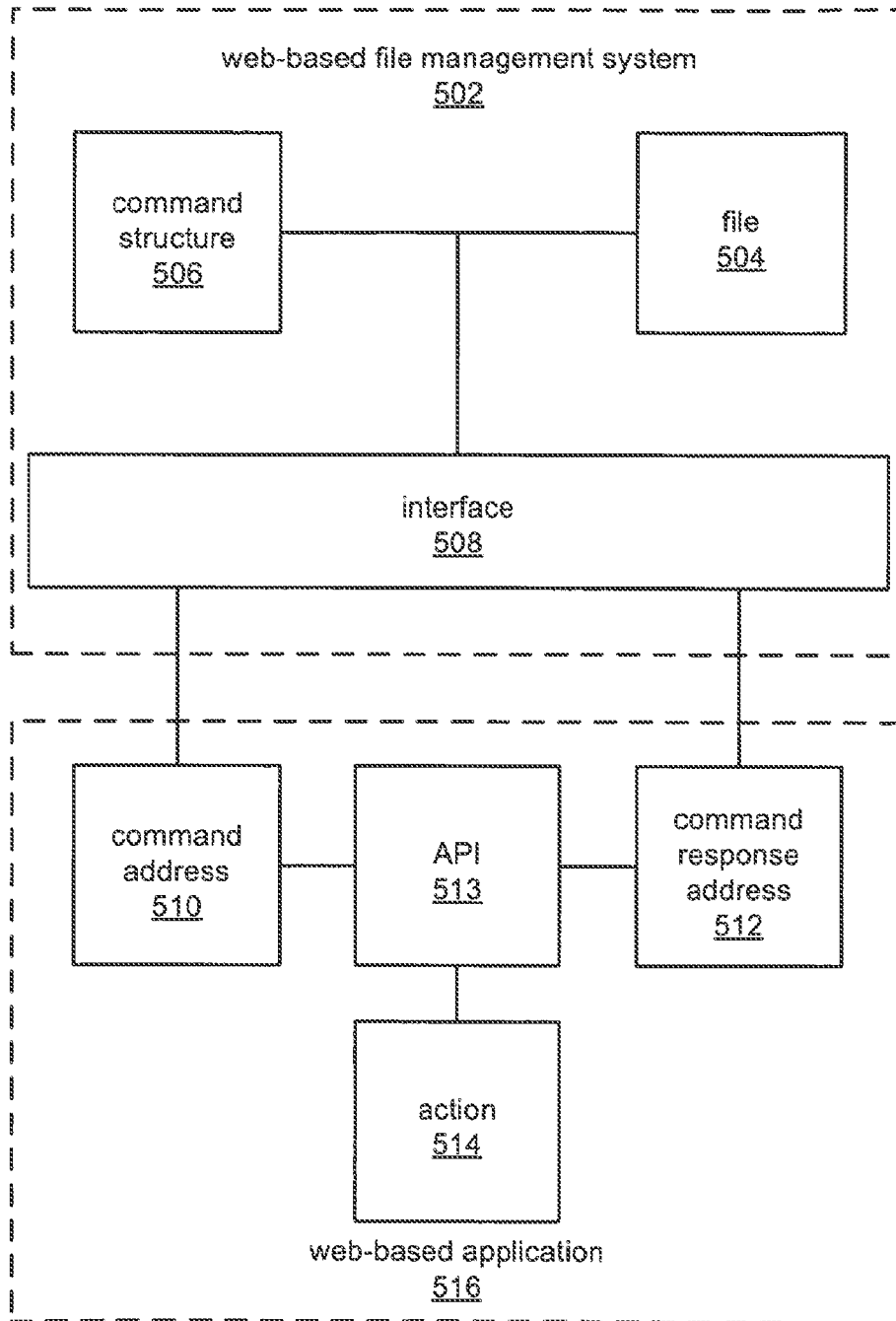

FIG. 5

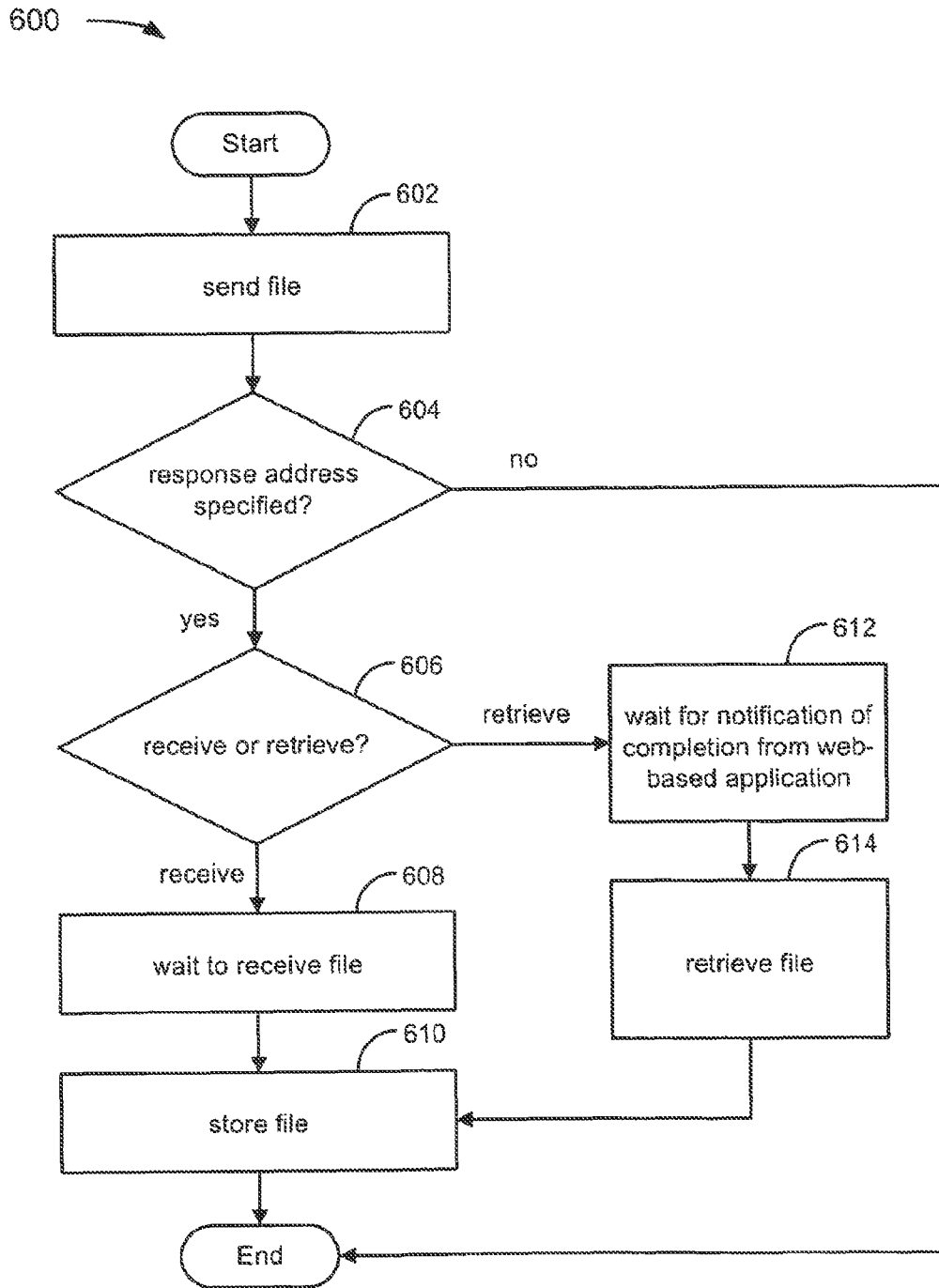

FIG. 6

700 →

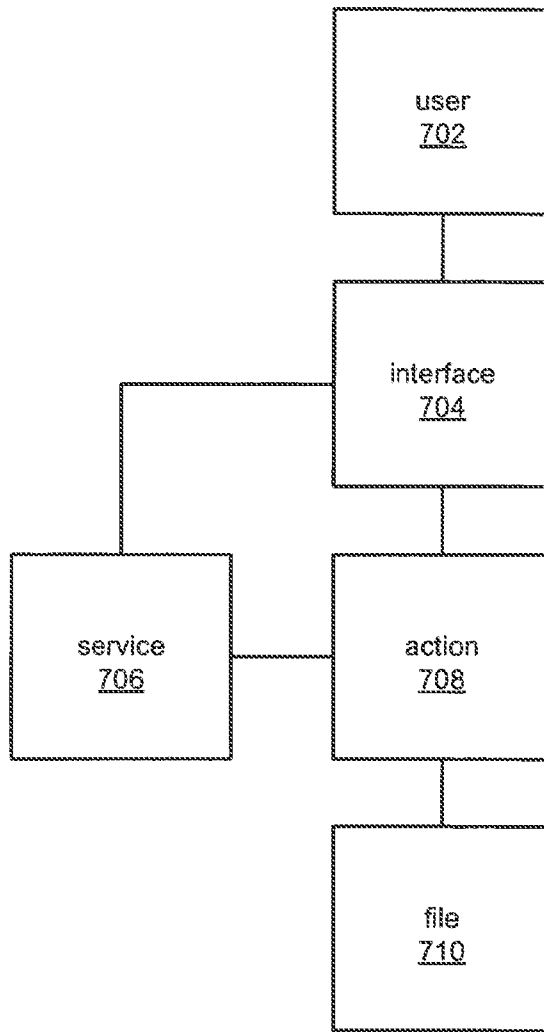

FIG. 7

800 →

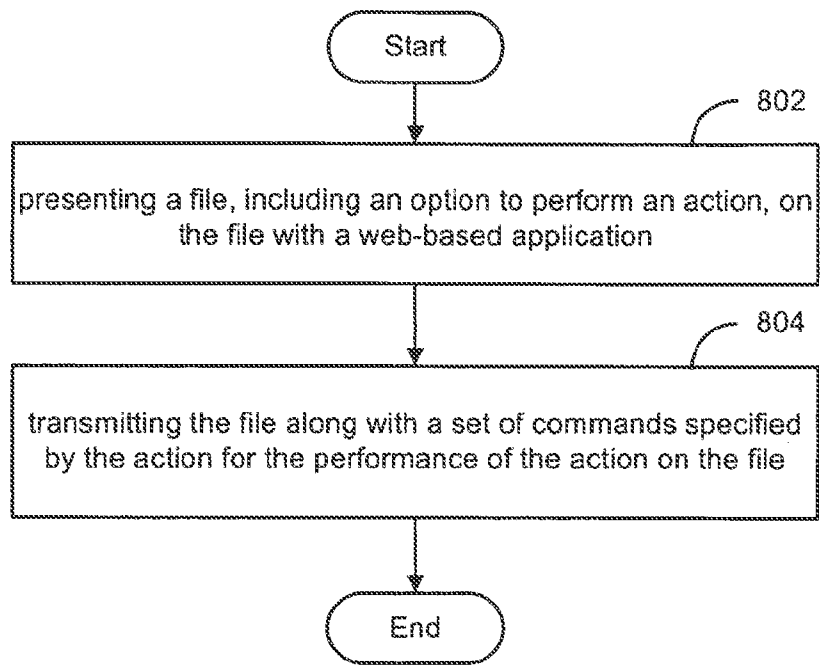

FIG. 8

900 →

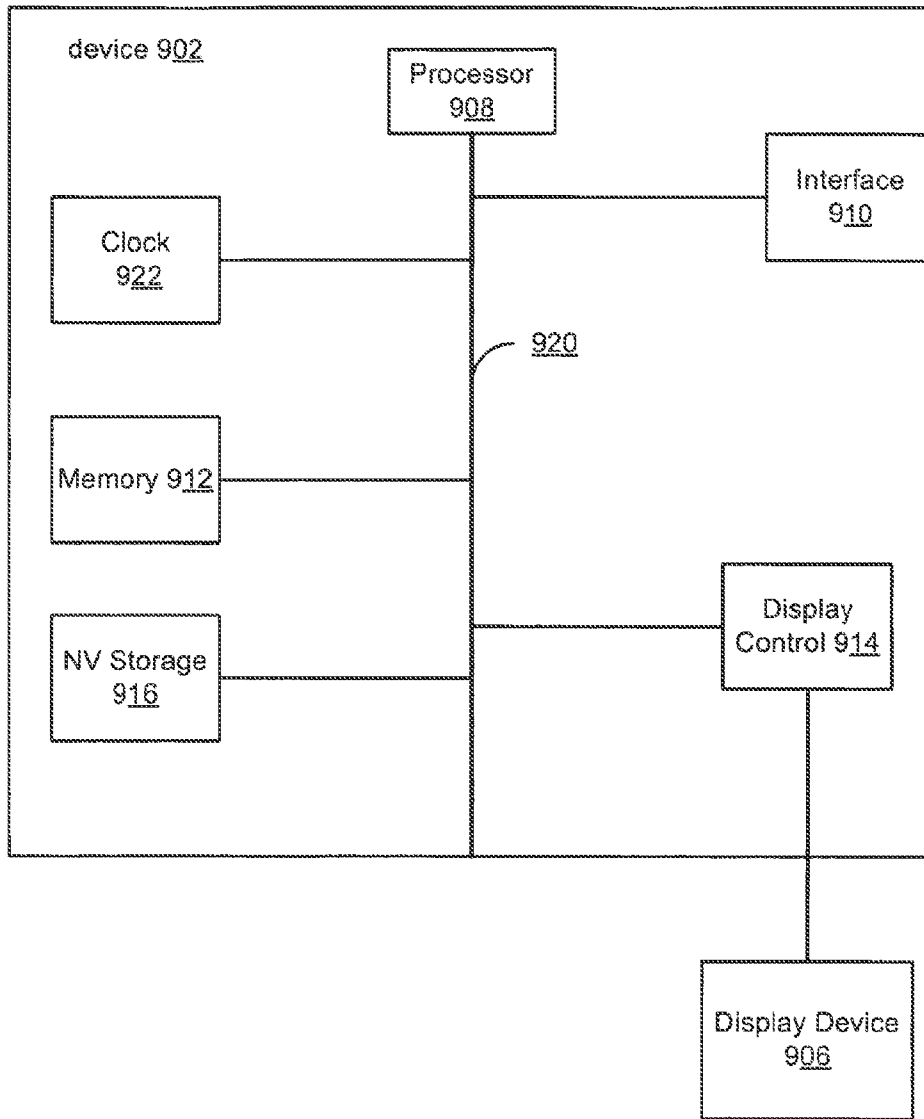

FIG. 9

Home My Files Updates Collaborators Services

You are currently in developer mode. Return to OpenBox as regular user.  
View the OpenBox documentation or contact us for questions or bug reports.

Step 1. Create an OpenBox Service ?

OpenBox enables Box.net users to send their data to and from your web or software application, or service. By using our simple API, you can be accepting data from Box users in no time. Please complete the following details to start using the OpenBox platform.

**General information:**

Service name:  Ex: Zoho

Service description:  Ex: Zoho is an online productivity suite

Support email:  Ex: support@zoho.com

Website URL:  Ex: http://zoho.com

URL of service description page:  (will be generated once service is saved) Page that will show the detail of this service to Box users. You can link to it from your website

Display in public service directory:  No  Yes (pending Box.net approval) If displayed in the public directory, your service will be visible to all Box users. Otherwise, it will be accessible only to users that know the service description page url.

**Trademark images of the service:**

Logo: No logo uploaded Displayed in services directory

Upload new logo:   Will be resized to 100x80

Favicon: No favicon uploaded Displayed in front of every action of the service, notably in drop down menu of files

Upload new favicon:   Will be resized to 16x16 (ico not accepted)

**Screenshots of the service:**

Upload new screenshot:   Will be resized to 570x570

Add description to new screenshot:

**Developers that can edit this service:**

1. N.Traiter@perkinscoie.com

Add a developer:  Email of a Box user that will be granted right to edit this service (limited to 5 people)

**Backend parameters:**

Api Key:  (will be generated once service is saved) Common api key for all actions Used to access Box.net APIs

**Service actions: ?**

No action created  
(you will be able to create new actions once service is saved)

Fig: Upload documents to your Box and then edit them from any web browser

FIG. 10

Home My Files Updates Collaborators Services

You are currently in developer mode. Return to OpenBox as regular user. View the OpenBox documentation or contact us for questions or bug reports.

Step 2. Create an OpenBox Action

OpenBox enables Box.net users to send their data to and from your web or software application, or service. By using our simple API, you can be accepting data from Box users in no time. Please complete the following details to start using the OpenBox platform.

General information: ?

Name:  Ex: Edit with Zoho

Description:  Ex: Open your document with Zoho Writer

Supported Extensions:  Ex: doc, png, gif, bmp  
Leave empty to accept all files

Permissions requirement:  Read permissions are enough (ie download only), then the action will be available on shared pages too

Category:  Previewing Displayed in the service directory

Filetype Category:  All Files Displayed in the service directory

Action Status:  Development (visible and executable only by the developers)  
 Online (visible and executable by all users of the action)  
 Maintenance (visible by all users of the action, but executable only by the developers)

Prompt parameters: ?

Prompt message:  Ex: Your file will be open by Zoho editor

Data type	Parameter name	Label	Default value	Remember
String	popup_param	Label 0	Default value 0	Yes
add prompt parameter		add section break		

Callback configuration: ?

User experience:  Your action will open a popup  
 Your action will run server-side only

Method:  REST Type of HTTP request that will be made to your server  
 XML  
 SOAP

Initial Callback URL:  URL for the initial HTTP request (probably uri to one of your API functions)

Method	Parameter name	Parameter value
Get		
add callback parameter		

Authentication: ?

Do you need HTTP Basic Authentication?  Yes  No If basic access authentication is needed, you will be able to choose login and password

Save new action Cancel

Drop down menu options:

- Read permissions are enough
- Full permissions are required
- Previewing
- Editing
- Converting
- Sharing
- Publishing
- Productivity
- Fun
- Communication
- Printing
- All files
- Documents
- Images
- Audio
- Video
- Miscellaneous
- String
- Password
- Textarea
- Radio
- Drop Down

FIG. 11

1

**FILE MANAGEMENT SYSTEM AND  
COLLABORATION SERVICE AND  
INTEGRATION CAPABILITIES WITH THIRD  
PARTY APPLICATIONS**

CROSS-REFERENCE TO RELATED  
APPLICATIONS

This application is a Continuation application of and claims the benefit of U.S. patent application Ser. No. 12/260,533, filed Oct. 29, 2008, entitled "WEB-BASED FILE MANAGEMENT SYSTEM AND SERVICE", which claims the benefit of U.S. Provisional Patent Application No. 60/992,656, filed Dec. 5, 2007, entitled "METHODS AND SYSTEMS FOR OPEN SOURCE COLLABORATION IN AN APPLICATION SERVICE PROVIDER ENVIRONMENT" and U.S. Provisional Patent Application No. 61/055,901, filed May 23, 2008, entitled "METHODS AND SYSTEMS FOR OPEN SOURCE INTEGRATION," all which are incorporated herein by reference.

This application is further related to U.S. patent application Ser. No. 13/412,549, filed Mar. 5, 2012, entitled "METHODS AND SYSTEMS FOR OPEN SOURCE COLLABORATION IN AN APPLICATION SERVICE PROVIDER ENVIRONMENT", which is a Continuation application of U.S. patent application Ser. No. 13/030,090, now U.S. Pat. No. 8,140,513, filed Feb. 17, 2011, entitled "METHODS AND SYSTEMS FOR OPEN SOURCE COLLABORATION IN AN APPLICATION SERVICE PROVIDER ENVIRONMENT", which claims the benefit of U.S. Provisional Patent Application No. 60/992,656, filed Dec. 5, 2007, entitled "METHODS AND SYSTEMS FOR OPEN SOURCE COLLABORATION IN AN APPLICATION SERVICE PROVIDER ENVIRONMENT" and U.S. Provisional Patent Application No. 61/055,901, filed May 23, 2008, entitled "METHODS AND SYSTEMS FOR OPEN SOURCE INTEGRATION," all which are incorporated herein by reference.

BACKGROUND

A server, or service class computing device, may be used to store files and to provide a website interface for one or more users of this website to access the files. An application developer may wish to make a service available to users of the website. This would allow the users to use the developer's application with the users' files.

In implementing a developer's service through an external website, one approach taken has been for the developer to make alterations to the application programming interface (API) of the software providing the service in order to enable the external software to communicate with the API of the developer's service. Significant resources and time may be required to implement the service through the external website by changing the API of the application providing the service. The developer is typically required to modify the API in a specific way to enable the application to send and accept data to and from the external application.

A provider of a website for file storage, sharing and collaboration may wish to make a plurality of services available to the users. Such users can then access the plurality of services from a single location to use with their files. The provider of the website may therefore wish to facilitate integration of services with its website.

The foregoing examples of the related art and limitations related therewith are intended to be illustrative and not

2

exclusive. Other limitations of the related art will become apparent upon a reading of the specification and a study of the drawings.

BRIEF DESCRIPTION OF THE DRAWINGS

FIG. 1 depicts an example of a system for integrating a web-based file management system (WBFMS) with a web-based application (WBA).

FIG. 2 depicts an example of a flowchart of an API-agnostic method for providing a plurality of WBAs to a user of a WBA.

FIG. 3 depicts an example of a system allowing a developer of a web-based application to integrate a service and an action with a web-based file management system through an interface of the web-based file management system.

FIG. 4 depicts an example of a flowchart of a method for configuring an action enabling files stored on a web-based file management system to interact with a web-based application.

FIG. 5 depicts an example of a system for integrating a web-based file management system with an API of a web-based application.

FIG. 6 depicts an example of a flowchart of a method for exchanging files between a web-based file management system and a web-based application.

FIG. 7 depicts an example of a system for providing an action of a web-based application to one or more files of a user of a web-based file management system.

FIG. 8 depicts an example of a flowchart of a method for performing an action on a file.

FIG. 9 depicts an example of a device for providing integration of a web-based file management system with a web-based application.

FIG. 10 depicts an example of a configuration interface, wherein a developer can enter values for a set of parameters to create a service.

FIG. 11 depicts an example of a configuration interface, wherein a developer can enter values for a set of parameters to create an action.

DETAILED DESCRIPTION

In the following description, several specific details are presented to provide a thorough understanding. One skilled in the relevant art will recognize, however, that the concepts and techniques disclosed herein can be practiced without one or more of the specific details, or in combination with other components, etc. In other instances, well-known implementations or operations are not shown or described in detail to avoid obscuring aspects of various examples disclosed herein.

A technique provides integration between a computer system storing files, a web based file management system (WBFMS), and a web based application (WBA). The WBA is operable to modify a file, perform another action with the file, or provide some other service. An application developer configures the WBA through an interface to integrate a service into the WBFMS to use the WBA, advantageously, without the application developer having to alter an application programmer interface (API) of the WBA.

An application programming interface (API) may be defined as a set of instructions programmable to cause a WBA to respond to one or more commands. An application or an individual may provide commands in accordance with the API to cause the WBA to perform an action.

To “send a file” includes at least one of the following and may include a combination of the following: send a copy of a file, send an indirection, link, or pointer to the file, send information about the file, or send a part or parts of the file.

The following examples and aspects thereof are described and illustrated in conjunction with systems, tools, and methods that are meant to be exemplary and illustrative, not limiting in scope. In various examples, one or more of the above-described problems have been reduced or eliminated, while other examples are directed to other improvements.

A technique provides an API-agnostic method and system for integrating a web-based file management system with one or more web-based applications to allow users of the web-based file management system to use the web-based application with files stored on the web-based file management system.

A system based on the technique may include a server storing one or more files of one or more users and providing a website for software developers to integrate their application with the website. This would make the application available to users of the website to use with the files stored on the web-based file management system.

A method based on the technique may include transmitting files from the web-based file management system to the web-based application along with a command structure of the API of the web-based application.

An integration engine allows a web-based file management system to provide an interface for an application developer to integrate a service in the web-based file management system, advantageously without the developer having to alter an API of the application providing the service. The integration engine acts as an intermediate between the web-based file management system and the web-based application, allowing them to communicate between each other.

A configuration interface on the web-based file management system provides a way for the developer to set up a service that acts on one or more files of a user of a web-based file management system, upon request of the user. The configuration parameters are stored on the web-based file management system and used whenever the service is requested by a user of the web-based file management system to act on a file stored on the web-based file management system.

A user interface allows a user of a web-based file management system to send, edit or view files that are stored on the web-based file management system with an external application.

FIG. 1 depicts a diagram 100 of an example of a method for API-agnostic integration of two software providers. FIG. 1 includes user(s) 102, web-based file management system (WBFMS) 104, integration engine 106, web-based application (WBA) 108 and developer(s) 110.

In the example of FIG. 1, the user 102 may be an individual or machine acting on behalf of an individual, having access to the internet through a computing device. As an individual, the user 102 may use an internet browser window, such as Internet Explorer or Mozilla Firefox to access the internet.

In the example of FIG. 1, the WBFMS 104 may provide online storage where users of the WBFMS 104 can store their files. The WBFMS 104 may also provide for file sharing and collaboration among users, as well as application services provided locally. The WBFMS 104 may include any computer readable medium capable of storing

data. The WBFMS 104 may provide a user interface through which users can access and manage files stored on the WBFMS 104.

In the example of FIG. 1, the integration engine 106 includes a processor executing instructions operable to provide commands to a WBA 108. The integration engine 106 may include an interface for configuring one application to work with the other.

In the example of FIG. 1, the WBA 108 may be software providing services to users through the internet. These services may, in a non-limiting example, include modifying or viewing a file or sending it via fax.

In the example of FIG. 1, the developer(s) 110 may be an individual, organization, or machine acting on behalf of an individual or organization, involved in the development process of an application. The developer(s) 110 may have knowledge of the API of the application.

The user 102 may access the WBFMS 104 via a computing device connected to the internet. The WBFMS 104 may provide online storage wherein users can store files. The user 102 may then upload files to the WBFMS 104 or view files already stored on the WBFMS 104. Files stored on the WBFMS 104 may be used with the WBA 108 via an integration engine 106. The developer(s) 110 are connected to the WBA 108 and to the integration engine 106. The developer(s) 110 may configure the integration engine 106, such that the WBA 108 can integrate with the WBFMS 104, without having to change the API of the service provided by the WBA 108. Integration will be discussed in further detail below, however, as a limited introduction, such configuration typically includes transmitting commands to the integration engine 106 for the integration engine 106 to provide to the WBA 108 along with a file. Upon a request from the user 102 of the WBFMS 104, the integration engine 106 sends the requested file along with a command structure of the API of the WBA 108 to the WBA 108.

FIG. 2 depicts an example of a flowchart of an API-agnostic method for providing a plurality of WBAs to a user of a WBA.

In the example of FIG. 2, the flowchart starts at module 202 with providing a web based file management system which provides users web-based file management services. These services may include storing files and providing access to these files to users of the WBFMS.

In the example of FIG. 2, the flowchart continues to module 204 with providing the user of the web-based file management system access to a plurality of web-based applications, each web-based application having a specific API. These WBAs may be used on files stored on the WBFMS and may, in a non-limiting example include modifying or viewing the file.

In the example of FIG. 2, the flowchart continues to module 206 with providing an integration engine configurable for the web-based application, the integration engine providing a file from the file management system and one or more commands prepared using one or more well-defined parameters.

In the example of FIG. 2, the flowchart continues to module 208 with providing a web-based interface for configuring the integration engine by a developer entering values for the set of well-defined parameters. Having provided a web-based interface, the flowchart terminates.

FIG. 3 depicts an example of a system 300 allowing a developer of a web-based application (WBA) to integrate a service and an action with a web-based file management system through an interface of the web-based file management system (WBFMS).

## 5

In the example of FIG. 3, WBFMS 302 includes service information 304, action information 306, and configuration interface 308.

In the example of FIG. 3, the service information 304 may include, but is not limited to, any combination of the following: the name of the service, a description, email contact information for support, a URL to the service description page, access control parameters, one or more pictures identifying the service, and an API key.

The API key is generated by the WBFMS 302 and is used for all actions of the WBA 312 that access the API of the WBFMS 302. In a non-limiting example, the WBA 312 can perform the following functions using the API of the WBFMS 302: store and retrieve files from the WBFMS 312, organize files into folders, move, rename or delete files, and share files.

The access control parameters may define whether the service defined by the service information 304 is visible to all users of the WBFMS 302, or whether it is only accessible to users that know the URL of the service description page.

In the example of FIG. 3, the action information 306 may include, but is not limited to, any combination of the following: a name of the action, a description, a list of supported file extensions, permission information, a command language, a command address, a command response address, one or more commands, and a security parameter.

The permission information defines the availability of an action for shared files on the WBFMS 302. The command language may be specified and is the computer language in which the command of the API is transmitted from one program to another. The security parameters determine whether or not access authentication is required to access the WBA 312.

In the example of FIG. 3, the configuration interface 308 may be a web interface such as an extensible hypertext markup language (XHTML)/hypertext markup language (HTML) form wherein data can be entered.

In the example of FIG. 3, the application developer 310 may be an individual, organization, or machine acting on behalf of an individual or organization, involved in the development process of an application.

In the example of FIG. 3, the WBA 312 may be a computing device executing instructions to provide services to users through the internet. These services may, in a non-limiting example, include modifying or viewing an image file or sending a file by fax.

In the example of FIG. 3, the service information 304 may be provided by the application developer 310 through the configuration interface 308. This information may be stored on a server of the WBFMS 302. The application developer 310 may use the configuration interface 308 to provide the action information 306. This information is then stored on the WBFMS 302. To enable the WBA 312 to accept data from the WBFMS 302, the developer 310 may use the configuration interface 308 to define the commands that are sent and received to and from the WBFMS 302.

FIG. 4 depicts a flowchart 400 of an example of a method for configuring an action enabling files stored on a web-based file management system to interact with a web-based application.

In the example of FIG. 4, the flowchart starts at module 402 with requesting action information used to enable the web-based file management system to interact with the web-based application. The WBFMS may send this request to a developer of a WBA wishing to set up a service of the WBA for users of the WBFMS.

## 6

In the example of FIG. 4, the flowchart continues to module 404 with receiving the action information to be performed on one or more files in response to the request. The developer of the WBA may provide the action information, which may then be sent to the WBFMS.

In the example of FIG. 4, the flowchart continues to module 406 with creating an action incorporating the action information. This information may then be stored on the WBFMS. Having created the action, the flowchart terminates.

FIG. 5 depicts a diagram 500 of an example of a method for integrating a web-based file management system with an API of a web-based application. FIG. 5 includes web-based file management system 502, and web-based application 516.

In the example of FIG. 5, web-based file management system 502 includes command structure 506, file 504 and interface 508. In the example of FIG. 5, web-based application 516 includes command address 510, command response address 512, API 513, and action 514.

In the example of FIG. 5, the command structure 506 may include code lines in the language of the API 513 of the web based application 516. The code lines can that provides the functionality described by the API 513.

In the example of FIG. 5, the file 504 may be a sequence of binary digits that can be read by a computer program, and can, in a non-limiting example, be presented to a user as, for example, text, an image, a presentation, or another known or convenient item.

In the example of FIG. 5, the interface 508 is a device that provides communication between information processing systems. The interface 508 may send data to an information processing system, and receive data from the information processing system.

In the example of FIG. 5, the command address 510 may be given by a Uniform Resource Locator (URL).

In the example of FIG. 5, the command response address 512 may be given by a Uniform Resource Locator (URL).

In the example of FIG. 5, the API 513 is an interface enabling computer programs to interact between each other. The API 513 may send commands to instruct a computer program to perform an action on a file.

In the example of FIG. 5, the action 514 may include a computer program acting on a file. In a non-limiting example, this may include modifying or displaying the file, or sending the file to another computer program.

Upon request of a user of the WBFMS 502, the WBFMS 502 sends a file 504 along with a command structure 506 to the WBA 516 through the interface 508. The specific location where the file 504 and command structure 506 are sent is given by the command address 510, and the file 504 and command structure 506 are then forwarded to the API 513. The action 514 is then applied to the file 504 using the API of the WBA 516 in accordance with the command structure 506. The file 504 may be sent back to the WBFMS 502 through the command response address 512, and stored on the WBFMS 502. The user of the WBFMS 502 may choose to either overwrite the original file when the modified file is received, or create a new file, which may be stored on the WBFMS 502. The WBFMS 502 may impose constraints on the write privileges of the user on the files.

FIG. 6 depicts a flowchart 600 of an example of a method for exchanging files between a web-based file management system and a web-based application.

In the example of FIG. 6, the flowchart starts at module 602 with sending a file from a WBFMS to a WBA.

In the example of FIG. 6, the flowchart continues to module 604 with determining whether a response address is specified. The response address can be specified by a developer of a WBA and can determine how the file is sent back to the WBFMS.

If the decision at module 604 is yes, then the flowchart continues to module 606 with determining whether to receive or to retrieve? The WBA may be set up to send the file back to the WBFMS upon completion of the requested action on the file. If the WBA is set up to make the file available for download upon completion of the action on the file, the WBFMS may retrieve it from the WBA.

If the decision at module 606 is receive, then the flowchart continues to module 608 with waiting to receive file. The WBFMS waits until the file has been transmitted from the WBA.

In the example of FIG. 6, the flowchart continues to module 610 with storing the file. The file may be stored by the WBFMS on any computer readable medium capable of storing data.

If the decision at module 606 is retrieve, then the flowchart continues to module 612 with waiting for notification of completion from the WBA.

In the example of FIG. 6, the flowchart continues to module 614 with retrieving the file from the WBA. The WBFMS may retrieve the file from the specified response address.

In the example of FIG. 6, the flowchart continues to module 610 with storing the file. Having stored the file on the WBFMS the flowchart terminates.

If the decision at module 604 is no, then the flowchart terminates.

FIG. 7 depicts a diagram 700 of an example of a system for providing an action of a web-based application to one or more files of a user of a web-based file management system. FIG. 7 includes user 702, interface 704, service 706, action 708, and file 710.

In the example of FIG. 7, the user 702 may be an individual or machine acting on behalf of an individual, having access to the internet through a computing device. The user 702 may use an internet browser window, such as Internet Explorer, available from Microsoft Corporation of Redmond, Wash., or Firefox, available from Mozilla Corporation of Mountain View, Calif., to access the internet.

In the example of FIG. 7, the configuration interface 704 may be a web interface with an XHTML/HTML form wherein data can be entered.

In the example of FIG. 7, the service 706 may include information on how the service 706 will act on files. The service 706 may include more than one option to modify or display files.

In the example of FIG. 7, the action 708 may include a computer program acting on a file. In a non-limiting example, this may include modifying or displaying the file, or sending the file to another computer program.

In the example of FIG. 7, the file 710 may be a sequence of binary digits that can be read by a computer program, and can, in a non-limiting example, be presented to a user as text, image, or PowerPoint presentation.

In the example of FIG. 7, the interface 704 may include a website allowing the user 702 to access files stored on the WBFMS. The user 702 may be given the option to use the action 708, determined by the service 706, on the file 710.

In the example of FIG. 7, the user 702 may select a service and may receive a file 710, without the action 708 being

requested by the user 702. An example of this would be a web-based fax service uploading received faxes to the WBFMS.

FIG. 8 depicts a flowchart 800 of an example of a method for providing a user with services from a WBA.

In the example of FIG. 8, the flowchart starts at module 802 with presenting a file, including an option to perform an action on the file, with a WBA. The file may be graphically displayed to a user via, for example, a web browser. The option to perform the action could be graphically represented as a clickable, selectable, or otherwise chosen.

In the example of FIG. 8, the flowchart continues to module 804 with transmitting the file along with a set of commands specified by the action for the performance of the action on the file. The commands instruct an API of a WBA to perform an action on the file. Having transmitted the file along with a set of commands, the flowchart terminates.

FIG. 9 depicts an example of a system 900 for integrating a web-based file management system with a web-based application through an API-agnostic method. The system 900 may be a conventional computer system that can be used as a client computer system, such as a wireless client or a workstation, or a server computer system. The system 900 includes a device 902, and a display device 906. The device 902 includes a processor 908, a communications interface 910, memory 912, display controller 914, non-volatile storage 916, clock 922. The device 902 may be coupled to or include the display device 906.

The device 902 interfaces to external systems through the communications interface 910, which may include a modem or network interface. It will be appreciated that the communications interface 910 can be considered to be part of the system 900 or a part of the device 902. The communications interface 910 can be an analog modem, ISDN modem or terminal adapter, cable modem, token ring IEEE 802.5 interface, Ethernet/IEEE 802.3 interface, wireless 802.11 interface, satellite transmission interface (e.g. "direct PC"), WiMAX/IEEE 802.16 interface, Bluetooth interface, cellular/mobile phone interface, third generation (3G) mobile phone interface, code division multiple access (CDMA) interface, Evolution-Data Optimized (EVDO) interface, general packet radio service (GPRS) interface, Enhanced GPRS (EDGE/EGPRS), High-Speed Downlink Packet Access (HSPDA) interface, or other interfaces for coupling a computer system to other computer systems.

The processor 908 may be, for example, a conventional microprocessor such as an Intel Pentium microprocessor or Motorola power PC microprocessor. The memory 912 is coupled to the processor 908 by a bus 920. The memory 912 can be Dynamic Random Access Memory (DRAM) and can also include Static RAM (SRAM). The bus 920 couples the processor 908 to the memory 912, also to the non-volatile storage 916, and to the display controller 914.

The display controller 914 may control in the conventional manner a display on the display device 906, which can be, for example, a cathode ray tube (CRT) or liquid crystal display (LCD). The display controller 914 can be implemented with conventional well known technology.

The non-volatile storage 916 is often a magnetic hard disk, flash memory, an optical disk, or another form of storage for large amounts of data. Some of this data is often written, by a direct memory access process, into memory 912 during execution of software in the device 902. One of skill in the art will immediately recognize that the terms "machine-readable medium" or "computer-readable medium" includes any type of storage device that is accessible by the processor 908.

Clock 922 can be any kind of oscillating circuit creating an electrical signal with a precise frequency. In a non-limiting example, clock 922 could be a crystal oscillator using the mechanical resonance of vibrating crystal to generate the electrical signal.

The system 900 is one example of many possible computer systems which have different architectures. For example, personal computers based on an Intel microprocessor often have multiple buses, one of which can be an I/O bus for the peripherals and one that directly connects the processor 908 and the memory 912 (often referred to as a memory bus). The buses are connected together through bridge components that perform any necessary translation due to differing bus protocols.

Network computers are another type of computer system that can be used in conjunction with the teachings provided herein. Network computers do not usually include a hard disk or other mass storage, and the executable programs are loaded from a network connection into the memory 912 for execution by the processor 908. A Web TV system, which is known in the art, is also considered to be a computer system, but it may lack some of the features shown in FIG. 9, such as certain input or output devices. A typical computer system will usually include at least a processor, memory, and a bus coupling the memory to the processor.

In addition, the system 900 is controlled by operating system software which includes a file management system, such as a disk operating system, which is part of the operating system software. One example of operating system software with its associated file management system software is the family of operating systems known as Windows® from Microsoft Corporation of Redmond, Wash., and their associated file management systems. Another example of operating system software with its associated file management system software is the Linux operating system and its associated file management system. The file management system is typically stored in the non-volatile storage 916 and causes the processor 908 to execute the various acts required by the operating system to input and output data and to store data in memory, including storing files on the non-volatile storage 916.

FIG. 10 depicts an example of a configuration interface, wherein a developer can enter values for a set of parameters to create a service.

In the example of FIG. 10, the WBFMS provides a web form, wherein the developer may enter values for well-defined parameters to create a service. Upon approval of the WBFMS, the service is made available to users of the WBFMS, and may be used with files stored on the WBFMS.

In the example of FIG. 10, the parameters may include general information, wherein the information provided by the developer may include the name of the service, a description of the service, an email address for support, a URL to a detailed description of the service, and an option to display the service in a public directory.

In the example of FIG. 10, the parameters may include the option to upload images and screenshots defining the service.

In the example of FIG. 10, the parameters may include the option to grant rights to other developers to edit the service.

In the example of FIG. 10, the parameters may include the option to create an action associated with the service.

FIG. 11 depicts an example of a configuration interface, wherein a developer can enter values for a set of parameters to create an action.

In the example of FIG. 11, the parameters may include general information about the action, including: the name of

action, a description of action, a list of extensions of supported files, permission information defining the availability of an action for shared files on the WBFMS, the category the action falls in, and status information defining whether the action is visible to and executable by the users of the WBFMS.

In the example of FIG. 11, the parameters may include prompt parameters, which define what is shown to the user when the user applies an action to a file stored on the WBFMS. These parameters may include a string, a password prompt, a text area, a radio button, and a drop down menu, or any combination of the above.

In the example of FIG. 11, the developer may configure callback options. These options may include an option to run the service in a new window, the language in which the WBFMS communicates with the WBA, a URL to the command address, and a URL to the command response address.

In the example of FIG. 11, the developer may define the parameters for the commands that are sent from the WBFMS to the WBA.

In the example of FIG. 11, the developer may choose to require authentication from the user of the WBFMS when the action is requested by the user.

Some portions of the detailed description are presented in terms of algorithms and symbolic representations of operations on data bits within a computer memory. These algorithmic descriptions and representations are the means used by those skilled in the data processing arts to most effectively convey the substance of their work to others skilled in the art. An algorithm is here, and generally, conceived to be a self-consistent sequence of operations leading to a desired result. The operations are those requiring physical manipulations of physical quantities. Usually, though not necessarily, these quantities take the form of electrical or magnetic signals capable of being stored, transferred, combined, compared, and otherwise manipulated. It has proven convenient at times, principally for reasons of common usage, to refer to these signals as bits, values, elements, symbols, characters, terms, numbers, or the like.

It should be borne in mind, however, that all of these and similar terms are to be associated with the appropriate physical quantities and are merely convenient labels applied to these quantities. Unless specifically stated otherwise as apparent from the following discussion, it is appreciated that throughout the description, discussions utilizing terms such as “processing” or “computing” or “calculating” or “determining” or “displaying” or the like, refer to the action and processes of a computer system, or similar electronic computing device, that manipulates and transforms data represented as physical (electronic) quantities within the computer system’s registers and memories into other data similarly represented as physical quantities within the computer system memories or registers or other such information storage, transmission or display devices.

The present example also relates to apparatus for performing the operations herein. This Apparatus may be specially constructed for the required purposes, or it may comprise a general purpose computer selectively activated or reconfigured by a computer program stored in the computer. Such a computer program may be stored in a computer readable storage medium, such as, but is not limited to, read-only memories (ROMs), random access memories (RAMs), EPROMs, EEPROMs, flash memory, magnetic or optical cards, any type of disk including floppy disks, optical disks, CD-ROMs, and magnetic-optical disks, or any type of

media suitable for storing electronic instructions, and each coupled to a computer system bus.

The algorithms and displays presented herein are not inherently related to any particular computer or other Apparatus. Various general purpose systems may be used with programs in accordance with the teachings herein, or it may prove convenient to construct more specialized Apparatus to perform the required method steps. The required structure for a variety of these systems will appear from the description below. In addition, the present example is not described with reference to any particular programming language, and various examples may thus be implemented using a variety of programming languages.

What is claimed is:

1. A method of a web-based file management system for collaboration, accessible via a website, comprising:

presenting options to perform one or more actions on a shared file stored on the web-based file management system for collaboration;

receiving a selection of the one or more actions to be performed on the shared file;

wherein, the selected one or more actions include a set of commands configured to cause a third-party web-based application to perform the selected one or more actions on the shared file; and

providing the third-party web-based application with access to the shared file along with the set of commands to perform the selected one or more actions on the shared file;

wherein, the web-based file management system for collaboration enables integration with the third-party web-based application via a configuration interface;

presenting options via the configuration interface to set values for one or more pre-defined parameters, the configuration interface accessible to a developer of the third-party web based application;

receiving, via the configuration interface, input values for the one or more predefined parameters; and

in response to receiving the selected one or more actions, generating the set of commands configured to cause the third-party web-based application to perform the selected one or more actions on the shared file, based on the received input values for the one or more predefined parameters.

2. The method of claim 1 wherein, the web-based file management system for collaboration is accessible via a wireless client.

3. The method of claim 1 further comprising: restricting the one or more actions that may be performed on the shared file based on permission information.

4. The method of claim 1, further comprising: presenting an option to enable posting or transmitting the shared file to another web-based media.

5. The method of claim 1, further comprising: presenting information regarding one or more actions previously performed on the shared file.

6. The method of claim 5 wherein, the information includes one or more from the group consisting of: a version history of the shared file, a use history of the shared file, a history of collaborators granted access to the shared file, permissions information history of the shared file, and a collaborator user access level history of the shared file.

7. The method of claim 1, wherein, the one or more actions include one or more from the group consisting of: create a new shared file, overwrite the shared file, organize the shared file into a folder, re-name the shared file, move the shared file, edit the shared file, display the shared file, delete

the shared file, add a collaborator user to the shared file, remove a collaborator user from the shared file, change a permission information for the shared file, and change a collaborator user access level for the shared file.

8. A method for providing a file management service for collaboration, comprising:

providing access to a shared file hosted by the file management service;

wherein, access enables collaboration on the shared file by a plurality of collaborator users via the file management service;

wherein, collaboration includes enabling one or more actions to be performed on the shared file;

receiving selections of the one or more actions to be performed on the shared file;

controlling the one or more actions to be performed on the shared file based on set permissions;

wherein, the selected actions include a set of commands configured to cause a third-party application to perform the selected one or more actions on the shared file;

providing the third-party application with access to the shared file along with the set of commands to perform the selected one or more actions on the shared file;

wherein, the file management service enables integration with the third-party application via a configuration interface;

presenting options via the configuration interface to set values for one or more pre-defined parameters, the configuration interface accessible to a developer of the third-party web based application;

receiving, via the configuration interface, input values for the one or more predefined parameters; and

in response to receiving the selected one or more actions, generating the set of commands configured to cause the third-party application to perform the selected one or more actions on the shared file based on the received input values for the one or more predefined parameters.

9. The method of claim 8, wherein, the client is provided through a wireless device.

10. The method of claim 8, further comprising:

presenting information regarding one or more actions previously performed on the shared file.

11. The method of claim 10, wherein, the information includes one or more from the group consisting of: a version history of the shared file, a use history of the shared file, a history of collaborators granted access to the shared file, permissions setting history of the shared file, and a collaborator user access level history of the shared file.

12. The method of claim 8, wherein, the one or more actions include one or more from the group consisting of: create a new shared file, overwrite the shared file, organize the shared file into a folder, re-name the shared file, move the shared file, edit the shared file, display the shared file, delete the shared file, add a collaborator user to the shared file, remove a collaborator user from the shared file, change a permission setting for the shared file, and change a collaborator user access level for the shared file.

13. A computer-readable medium including instructions stored thereon, which when executed by a processor of a computer system, cause the computer system to:

present options to perform one or more actions on a shared file stored on a web-based file management system for collaboration;

receive a selection of the one or more actions to be performed on the shared file;

13

wherein, the selected one or more actions include a set of commands configured to cause a third-party web-based application to perform the selected one or more actions on the shared file; and  
 provide the third-party web-based application with access to the shared file along with the set of commands to perform the selected one or more actions on the shared file;  
 wherein, the web-based file management system for collaboration enables integration with the third-party web-based application via a configuration interface;  
 present options via the configuration interface to set values for one or more pre-defined parameters, the configuration interface accessible to a developer of the third-party web based application;  
 receive, via the configuration interface, input values for the one or more predefined parameters; and  
 in response to receiving the selected one or more actions, generate the set of commands configured to cause the third-party web-based application to perform the selected one or more actions on the shared file based on the received input values for the one or more predefined parameters.

14. The computer-readable medium of claim 13 further comprising instructions stored thereon, which when executed by the processor, cause the computer system to further:

present options to enable posting or transmitting the shared file to another web-based media.

15. The computer-readable medium of claim 13 further comprising instructions stored thereon, which when executed by the processor, cause the computer system to further:

present information regarding one or more actions previously performed on the shared file.

16. The computer-readable medium of claim 15, wherein the information includes one or more from the group consisting of: a version history of the shared file, a use history of the shared file, a history of collaborators granted access to the shared file, permissions information history of the shared file, and a collaborator user access level history of the shared file.

17. The computer-readable medium of claim 13, wherein, the one or more actions include one or more from the group consisting of: create a new shared file, overwrite the shared file, organize the shared file into a folder, re-name the shared

14

file, move the shared file, edit the file, display the shared file, delete the shared file, add a collaborator user to the shared file, remove a collaborator user from the shared file, change a permission information for the shared file, and change a collaborator user access level for the shared file.

18. A method comprising:

presenting, by a server computer operating as part of a web-based file management system for collaboration, a graphical configuration interface that enables integration with a third-party web-based application, the graphical configuration interface accessible to a developer of the third-party web-based application, the graphical configuration interface including options to set values for one or more pre-defined parameters that define a service of the third-party web-based application, the service including an action that the third-party web-based application can take on a shared file stored in the web-based file management system;

receiving, by the server computer, via the graphical configuration interface, input values for the one or more predefined parameters;

in response to receiving the input values, generating and storing, by the server computer, a set of commands configured to cause the third-party web-based application to perform the action on the shared file;

presenting, by the server computer, a graphical user interface that includes options to perform one or more actions on the shared file stored on the web-based file management system for collaboration, the graphical user interface accessible to collaborator users of the shared file;

receiving, by the server computer, via the graphical user interface, a selection of the action to be performed on the shared file;

in response to receiving the selection of the action, automatically transmitting, by the server computer, via a computer network, a copy of the shared file along with the set of commands to perform the selected action on the copy of the shared file, to the third-party web-based application; and

receiving, by the server computer, via the computer network, from the third-party web-based application, an updated copy of the shared file, once the third-party web-based application has performed the action.

\* \* \* \* \*