

June 4, 1935.

A. W. MACHLET

2,003,970

BELL RETORT FURNACE

Filed Dec. 3, 1930

2 Sheets-Sheet 1

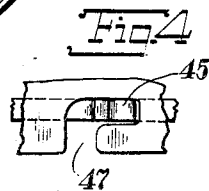
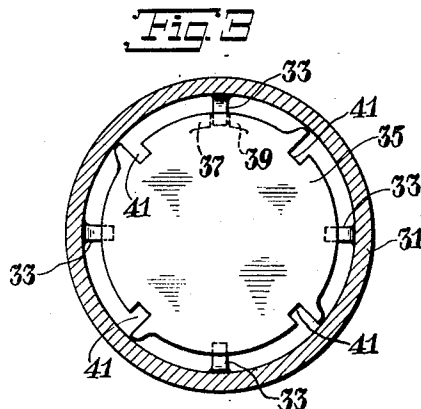
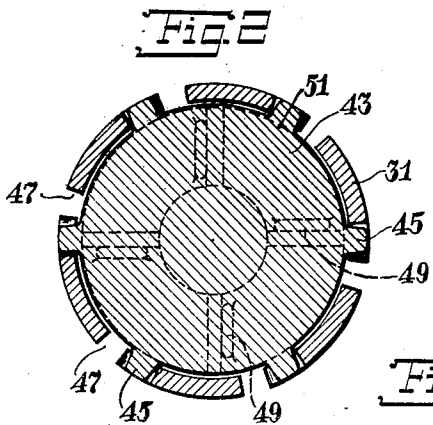
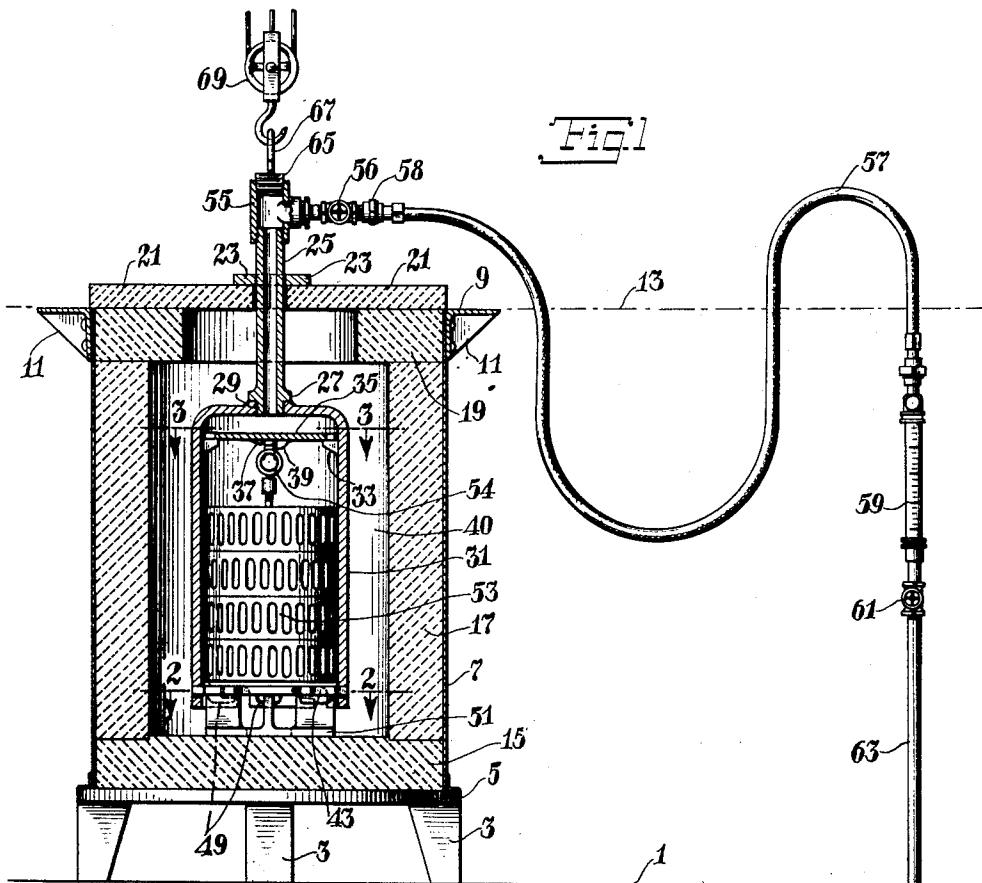

INVENTOR  
*Adolph W. Machlet*  
BY  
*Charles Messick*  
ATTORNEY

June 4, 1935.

A. W. MACHLET

2,003,970

BELL RETORT FURNACE

Filed Dec. 3, 1930

2 Sheets-Sheet 2

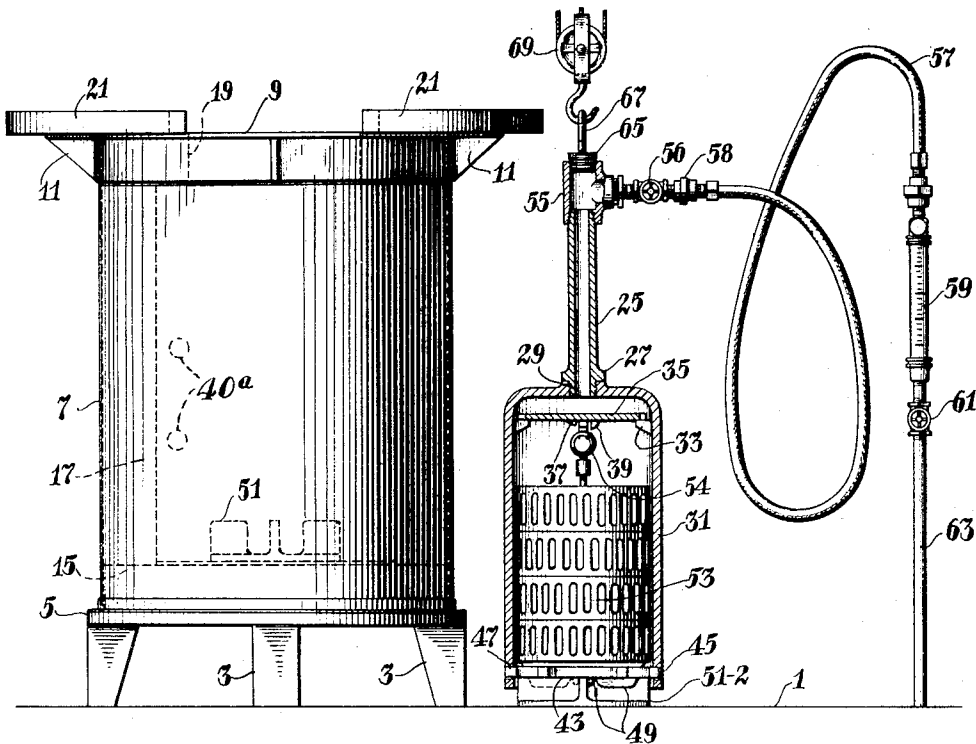
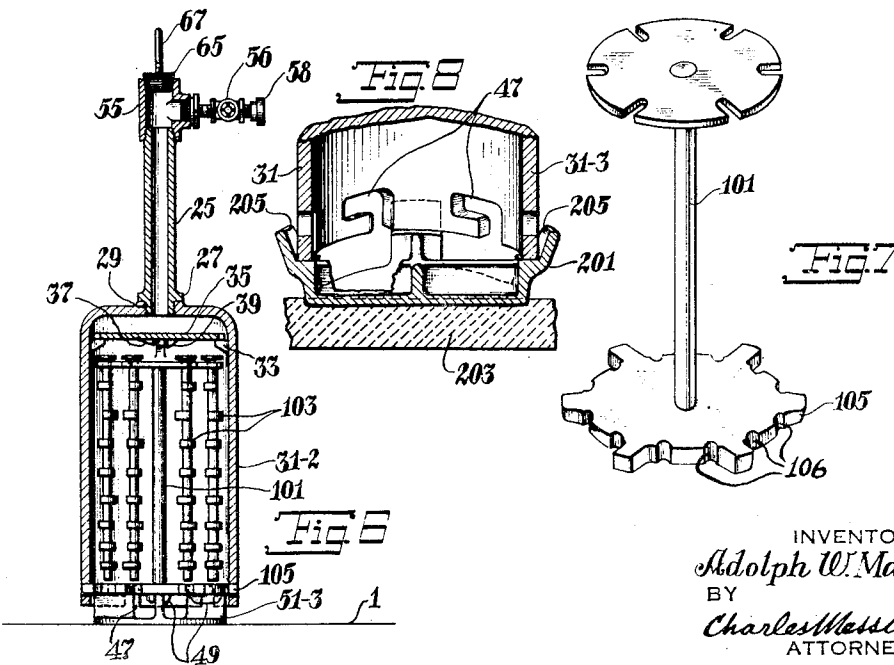

Fig 5



INVENTOR  
*Adolph W. Machlet*  
BY  
*Charles Messick*  
ATTORNEY

# UNITED STATES PATENT OFFICE

2,003,970

## BELL RETORT FURNACE

Adolph W. Machlet, Elizabeth, N. J.

Application December 3, 1930, Serial No. 499,634

Renewed December 9, 1932

24 Claims. (Cl. 266—5)

My invention pertains to heat treating, annealing, carburizing and nitriding furnaces generally, and more particularly to furnaces provided with a hot chamber containing a retort to

the work in the retort will remain bathed in the gas while cooling. Another object is to utilize the well known low specific gravity of heat treating gas to aid in keeping the gas in position to treat the work without the complications of gas-

hold the work.

The broad object of my invention is to increase the efficiency of such furnaces.

Another object is to provide a pipe, tube or duct, for the introduction of the treating material, preferably having low heat conductivity and small radiating surface, said pipe, tube or duct communicating at its lower end with the top of the bell retort, extending upwardly therefrom and being provided at its upper end with an attachment portion whereby it and the retort

Another object is to provide a furnace having a hot chamber which is convenient to manipulate for the insertion and withdrawal of the retort. Another object is to provide such a furnace in which both the retort and the work or a basket containing it can be easily withdrawn without disturbing the body of the hot chamber of such furnace. Another object is to improve the uniformity of temperature at all parts of the retort by avoiding unnecessary exposure outside the chamber of the mouth of the retort. Another object is to reduce heat losses. Another object is to effect fuel economy. Another object is to reduce the required amount of treating gas, oil, or other treating material. Another object is to introduce heat treating fluid at the top of the retort and vent it at the bottom so as to achieve uniform distribution of the fluid. Another object is to increase the convenience of operation. Another object is to reduce the amount and thus the first cost of apparatus required to perform a particular amount of work. Another object is to reduce the cost of the parts which are subject to wear and require occasional replacement, such for instance as the retort. Another object is to provide a retort of refractory metal of such a form as to require a minimum weight of such metal for any predetermined capacity and thereby reduce replacement cost. Another object is to provide guiding means to facilitate centering of the retort in the hot chamber and its removal therefrom. Another object is to facilitate opening and closing the top of the hot chamber for insertion or removal of the retort with a minimum of labor. Another object is to provide for heating the furnace and then successively treating in it several retorts full of work with a minimum loss of heat. Another object is to introduce the heat treating gas into the retort, effect the heat treatment therewith and vent the spent or partly spent gas into the hot chamber where the remaining combustible material of said gas, if any, will contribute to heating the hot chamber. Another object is to so seal the heat treating gas in the retort by this improved bell construction that even after the inflow of the heat treating gas is reduced to a bare trickle or completely shut off,

may be hoisted. Other objects will appear from the following detail description of the preferred construction and be pointed out in the appended claims.

Referring to the accompanying drawings:— Fig. 1 is a vertical section of my furnace and also shows some of the associated apparatus.

Fig. 2 is a horizontal cross section taken on the line 2—2 of Fig. 1, looking in the direction of the arrows.

Fig. 3 is a horizontal cross section taken on the line 3—3 of Fig. 1.

Fig. 4 is an enlarged fragment of the lower portion of the retort and the retort bottom of Fig. 1, particularly showing the bayonet locking arrangement by which the bottom is detachably secured to the retort.

Fig. 5 is a side elevation of the furnace of Fig. 1 in open condition and with the retort standing on the floor outside the furnace.

Fig. 6 shows a rack holding cam shafts in my retort in place of the basket shown in Figs. 1 and 5.

Fig. 7 is a perspective view of the rack of Fig. 6, and,

Fig. 8 is a perspective view of a retort support designed to guide the retort to a central position in the furnace and then to support the retort without touching the retort bottom.

The numeral 1 indicates a floor upon which the legs 3 of my furnace rest. The legs 3 support a bottom frame 5 which carries a cylindrical metal shell 7 provided at its upper end with a flange 9 supported upon ribs 11 which are secured to shell 7 as indicated in Fig. 1.

Referring to Fig. 1 in which a dot and dash line 13 appears. Dot and dash line 13 indicates the approximate level to which the top of my furnace may be sunk when installed in a trench as is conventional in certain classes of foundries, such for

instance as brass foundries, to facilitate the insertion and removal of the crucibles from the tops of such furnaces.

It will appear as this description proceeds that the loading and unloading of work, respectively into and out of my improved bell retort furnace, is through the top, so that it will in many cases be convenient to install such furnaces in trenches.

However, for operation of my bell retort furnaces like conventional heat treating furnaces, the installation will be on the floor, and in this case the dot and dash line 13 may be ignored.

Referring again to Fig. 1, my furnace is conventionally lined with insulating brick, 15, 17, 19, and provided with movable cover bricks 21 which are surmounted by half washers 23 fitting closely around the gas inlet pipe 25, to prevent the escape of heat.

Gas inlet pipe 25 is provided with a hexagonal portion 27, designed to form a grip for a wrench, and a threaded portion 29 which is securely threaded into the top of my bell retort 31. Retort 31 is provided with four internal lugs 33 which support a distributing plate 35 upon which are cast a small positioning lug 37 and a large stop lug 39. Retorts 31-2 and 31-3 are provided with similar members 33, 35, 37, and 39.

The space 40 enclosed by members 15, 17, 19, 21, and 23 and enclosing retort 31 in the position of Fig. 1, I term the "hot chamber" or more briefly the "chamber". Chamber 40 may be heated by burners 40<sup>a</sup> or in any other conventional manner, as the invention is not limited to the use of any specific heat-treating means, such as gas, oil, other fuels, or electricity. It may be cylindrical as shown or any other convenient shape such as square, oblong, etc., according to the requirements of a particular installation, to contain a retort of any such shape.

Chamber 40 may be conveniently opened by sliding the members 21 into the position of Fig. 5 where they are shown resting on the flange 9, which is one convenient means of holding members 21 while chamber 40 is open.

Plate 35 is inserted by hand with the notches 41 registering with the lugs 33 and then rotated to the indicated position, as may be best understood by reference to Figs. 1 and 3.

The lower portion of retort 31 is provided with a bottom plate 43 locked thereto by a bayonet lock 45-47 comprising six lugs 45 on plate 43 and six slots 47 formed at the lower end of retort 31. Bottom plate 43 is also provided with four projections 49 which may be used as crow bar holds to aid in forcing bayonet lock 45-47 if it gets jammed or clogged with dirt or scale.

Ordinarily, a conventional spider support 51 is provided in my furnace, upon which the bottom plate 43 rests. Similar supports 51-2 and 51-3 are shown resting on the floors in Figs. 5 and 6, respectively.

Referring to Fig. 1, it will be noted that retort 31 contains a conventional work holding basket 53 provided with a ring 54 at its upper end by means of which the basket may be lifted. It will be also observed that the gas inlet pipe 25 is preferably of refractory metal, having low heat conductivity and being of as small cross section and radiating surface as practical. The top of pipe 25 is provided with a conventional T 55 and a carburizing gas inlet hose 57 provided with a union 58 and a valve 56, leads to it from a flow meter 59 which is supplied through a valve 61 from a pipe 63. Pipe 63 is supplied from a source (not shown) of carburizing, nitrid-

ing or other heat treating gas, or mixture of gas and diluent under light pressure.

In operation, the heat treating gas, which, it may be observed, has usually a lower specific gravity than air at the same temperature, flows down pipe 25, spreads out on distributing plate 35, permeates the work in basket 53 and treats it, the spent gases exiting through the clearance spaces between plate 43 and retort 31, as may be seen best in Fig. 2. It will be observed from the foregoing that the gas leakage and wasteful heat radiation from my retort 31 are reduced to an irreducible minimum.

The more or less vitiated carburizing gas becomes ignited as it vents from the lower end of the retort, and produces heat which is auxiliary to the furnace thereof, or saving thereof, as the hot ignited gas from the vent rises around the retort and aids in maintaining or increasing the heat thereof. If desired, the heated retort may remain in the furnace after the supply of furnace fuel runs low or is cut off, and the furnace will remain heated for some time, though slowly cooling. The venting carburizing gas, as it ignites at the bottom of the retort, will maintain the heat of the same over a considerable period, thus saving the cost of furnace fuel, which may be reduced or cut off.

The furnace chamber 40 is not sealed nor airtight. The products of combustion may vent at the top thereof. The closure, or the half-washers 23, may be sufficiently closed to prevent objectionable loss of heat, but will still permit venting of burned gas.

The upper end of T 55 is provided with a screw plug 65 and eye 67 which may be engaged by a conventional hoist 69 when it is desired to lift the retort 31 out of the furnace, and place it to the right thereof as shown in Fig. 5.

In Fig. 7 a rack 101 is shown in which to suspend the several cam shafts 103, shown in Fig. 6, contained within one of my retorts 31-2. Rack 101 is provided with an integral bottom plate 105 in place of a bottom plate like the previously described bottom plate 43. Plate 105 is provided with spent gas vent notches 106.

When work such as shafts 102-103 is to be treated it is often desirable to remove the retort 31-2 and shafts 103, bodily from the furnace, to anneal, temper or process the work, and under such conditions, the union 58 is uncoupled and the assembly of Fig. 6 is set aside for annealing or other processing.

During such processing the hot chamber 40 would, in the conventional type of furnace, be left to cool off and waste heat, but I may have several retorts filled with work which may be successively heat treated in my chamber 40.

Referring particularly to Fig. 8, a special form of support 201 is shown resting in a shallow recess of a bottom brick 203 which may be substituted in a furnace for brick 15. Support 201 is provided with slanting guides 205 designed to centre and support a retort 31-3, which is similar to retort 31 above described, independent of the exact central position in which it is lowered by hoist 69.

Referring to Fig. 1, it may be noted that retort 31 may be unlocked at bayonet lock 45-47 and lifted out of chamber 40 without disturbing basket 53 which may then be separately removed and replaced with a fresh basket of work. It may be also noted that retorts 31, 31-2 and 31-3 are interchangeable.

Gas suitably diluted as required from any suit-

able source may be utilized. Gas-making oil may be substituted for such gas. The oil should be introduced in a very slow stream often only flowing a drop at a time down through pipe 25 and falling onto plate 35. Gas may also be provided in my retort by disconnecting union 58 and valve 56 and pouring down pipe 25 onto plate 35 a very small stream of powder containing suitable gas making elements. If either oil or powder is used it will gasify upon coming in contact with the hot distributor plate 35.

I do not limit myself to the particular construction shown, and the spirit of this invention which is pointed out in the following claims may be applied to various forms of heat treating furnaces in accordance with progress of the art.

I claim:—

1. A furnace for heat treating including a hot chamber having heat insulating walls, a separate bell retort confined and supported therein for removal from the top thereof, and designed to contain work, said retort being provided at the bottom with an opening through which the work may be inserted or removed, while the retort is out of the furnace, a means at the opening, separable from the retort, designed to hold the work, and a vent for spent gases at the means.

2. A furnace for heat treating including a hot chamber having heat insulating walls and a heat insulating openable top designed to normally cover a retort, a bell retort therein designed to contain work and provided with means at its upper end to facilitate its removal from the furnace through the top, said retort being provided at the bottom with an opening through which the work may be inserted or removed and a means at the opening, separable from the retort, designed to hold the work.

3. A furnace for heat treating including a hot chamber provided with heat insulating walls, a bell retort therein and designed to contain work, a lifting means at the upper end of the retort and means associated with the furnace whereby the retort may be guided to a predetermined position therein.

4. A bell retort provided with an inlet at the top having a tubular extension for the introduction of treating material, a charging opening at the bottom of the retort and an attachment portion on the extension whereby the retort and contents, if any, may be suspended.

5. The combination of a bell retort of refractory metal having a body portion and an opening at the bottom thereof provided with attachment means designed to suspend a removable bottom and an opening of a diameter smaller than that of the body portion at the top for the admission of treating material.

6. The combination of a bell retort having a body portion and a top opening of a diameter smaller than that of the body portion for the admission of a treating material, a distributor means for the material just below the opening and a charging opening for work at the bottom of the body portion.

7. A bell retort provided with an inlet at the top for the introduction of treating material, means to introduce such material at the inlet, an imperforate top and walls to confine the material and an opening at the bottom for loading the retort and venting spent material, said opening at the bottom including a perforate portion in the lower edge of the said walls.

8. An apparatus for carburizing metal articles

including a retort in the form of a bell in the upper portion of which the gas is trapped, means to cause a current of a carburizing gas to flow through the bell, the bell venting the gas at its lower portion, said bell having means carried thereby for removably supporting work in the upper portion of the bell.

9. An apparatus for heat-treating metal articles in the presence of a gas, including a retort in the form of a bell in which the gas is trapped, means to cause a current of gas to flow through the bell, the bell venting the gas at its lower portion, said bell having means carried thereby for removably supporting work, and a furnace having a heat-chamber in which the bell is wholly enclosed, said furnace including a portion which is movable to afford access to the bell, and means for removably supporting the bell wholly within said heat-chamber.

10. An apparatus for carburizing metal articles, including a retort in the form of a bell in which the gas is trapped, the bell venting the gas at its lower portion, said bell having means carried thereby for removably supporting work, a furnace having a heat-chamber in which the bell is wholly enclosed, and means extending within the furnace for supplying gas within the bell to cause a current of carburizing gas to flow down through the bell, while the latter is being heated in the heat-chamber.

11. An apparatus for heat-treating metal articles in the presence of a gas, including a retort in the form of a bell in which the gas is trapped, the bell venting the gas at its lower portion, said bell having means for removably supporting work, and a furnace having a heat-chamber in which the bell may be wholly enclosed, said furnace having an opening at the top thereof for the insertion and removal of said bell, and a removable closure for said opening, and also having means for supporting the bell within the heat-chamber of the furnace; the bell being removable through said top opening.

12. An apparatus for heat-treating metal articles in the presence of a gas, including a retort in the form of a bell in which the gas is trapped, the bell venting the gas at its lower portion, said bell having means for removably supporting work, and a furnace having a heat-chamber in which the bell may be wholly enclosed, said furnace having an opening at the top thereof for the insertion and removal of said bell, and a removable closure for said opening, and also having means for supporting the bell within the heat-chamber of the furnace, the bell being removable through said top opening, and a duct extending through said closure and into said bell for supplying gas to the latter while being heated.

13. An apparatus for heat-treating metal articles in the presence of a gas, including a retort in the form of a bell in which the gas is trapped, the bell venting the gas at its lower portion, said bell having means for removably supporting work, and a furnace having a heat-chamber in which the bell may be wholly enclosed, said furnace having an opening at the top thereof for the insertion and removal of said bell, and a closure for said opening, and also having means for removably supporting the bell within the heat-chamber of the furnace, and a duct extending through said closure and into said bell for supplying gas to the latter while being heated, and means for raising the bell out of the furnace through said opening.

14. An apparatus for heat-treating metal arti-

cles in the presence of a gas, including a retort in the form of a bell in which the gas is trapped, the bell venting the gas at its lower portion, said bell having means for removably supporting work, and a furnace having a heat-chamber in which the bell may be wholly enclosed, said furnace having an opening at the top thereof for the insertion and removal of said bell, and a closure for said opening, and also having means for removably supporting the bell within the heat-chamber of the furnace, and a duct extending through said closure and into said bell for supplying gas to the latter while being heated, and means for raising the bell out of the furnace through said opening, together with said duct, said duct having a flexible portion, and means for supplying gas through said duct to said bell.

15. The combination of a furnace having a heating chamber provided in its upper portion with an opening having a closable lid, a work-retort insertible through said opening, means for supporting the retort wholly within the heating chamber, said retort venting from its lower portion only, and means for feeding gas through said retort from top to bottom while confined in said heating chamber.

16. The combination with a retort, of a furnace having a heating chamber formed with a top and having an opening in its top for the insertion of the retort and a lid to close said opening, and also having an interior support fitted to the retort to locate it centrally in the heating chamber, and means to feed gas to said retort while confined in said heating chamber; said retort venting only at its lower end.

17. The combination with a retort, of a furnace having a heating chamber formed with a top and having an opening in its top for the insertion of the retort and a lid to close said opening, and also having an interior support fitted to the retort to locate it centrally in the heating chamber, means to feed gas to said retort while confined in said heating chamber; said retort venting only at its lower end; and means operable for raising the heated retort out of the heating chamber, and depositing a fresh work-containing retort in the heating chamber while the furnace remains in highly heated working condition.

18. A furnace for heat-treating, including a hot chamber having heat-insulating walls a work-containing bell-retort wholly within the furnace and movable to and from the furnace and serving to trap the gas in which the work is treated, and means to cause a current of gas to flow through the retort, said retort venting at its bottom only, and having an open bottom through which the work may be inserted or removed, said retort having a work-holding container in its bottom, and having means for removably supporting said container.

19. A fixed furnace for heat-treating, including a hot chamber having heat-insulating walls, a portable work-containing bell-retort wholly within the furnace and movable to and from the furnace, and means to cause a current of gas to flow through said retort, the latter serving to

trap the gas in which the work is treated, said retort having work-supporting means and venting at its bottom only, the vented gas rising within the furnace, and having a constantly open bottom through which the work may be inserted or removed from the withdrawn retort, said furnace having an opening in its top for insertion and withdrawal of the retort with its load.

20. Means for heat-treating metal articles in an atmosphere of combustible gas, including a furnace, and a portable bell-retort in which the gas is trapped, said retort provided in its top with a tubular upwardly extending feed-pipe for gas or material, said retort entirely separate and distinct from a furnace, means for dropping the retort into and lifting it out of the furnace, said retort venting ignited gas only at its lower end, and directly into the furnace, and having a charging opening through which when removed from the furnace it may be charged with work, and having means for removably supporting the work contained therein.

21. A furnace for heat treating including a hot chamber having heat insulating walls, a separate bell retort confined and supported therein for removal from the top thereof, and designed to contain work, means for lifting said bell out of the retort, said retort being provided at the bottom with an opening through which the work may be inserted or removed, while the retort is out of the furnace, a means at the opening, separable from the retort, designed to hold the work, and a bottom vent for ignited spent gases at the work-holding means.

22. In combination, a furnace, a bell retort provided with an inlet at the top for the introduction of treating material, said retort being provided with an otherwise imperforate top, imperforate walls adjacent to the top and an opening at the bottom whereby the ignited spent treating material may exit, and rise within the furnace, and means for lifting the retort out of the furnace.

23. An apparatus for heat-treating metal articles in the presence of a gas, including a retort in the form of a bell in which the gas is trapped, the bell venting the ignited gas at its lower portion, to continue heating the work, said bell having means for removably supporting work, a furnace having a heat-chamber in which the bell is wholly enclosed, means for lifting the bell out of the furnace, and means extending within the furnace for supplying fresh gas within the bell while the latter is being heated in the heat-chamber, said gas-supplying means including a duct extending down through the top of the furnace into said bell.

24. The combination with a furnace, of a bell retort entirely separate and distinct from the furnace, means for dropping the bell into and lifting it out of the furnace, said bell being provided with an inlet at the top for the introduction of treating material, means to introduce such material at the inlet, solid walls to confine the material, and an opening at the bottom for loading the retort and venting spent material in ignited condition.

ADOLPH W. MACHLET.