

Aug. 17, 1965

H. R. JONES

3,200,902

REPLACEABLE CARTRIDGE ACOUSTICAL MUFFLER

Filed April 7, 1964

2 Sheets-Sheet 1

Fig. 1.

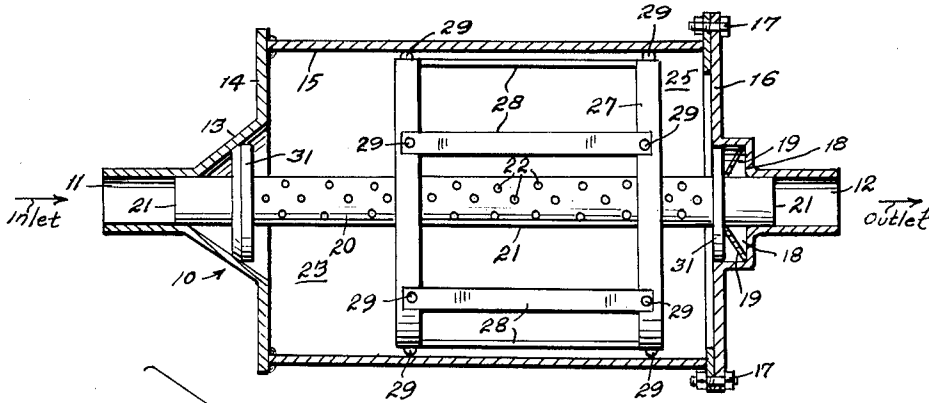
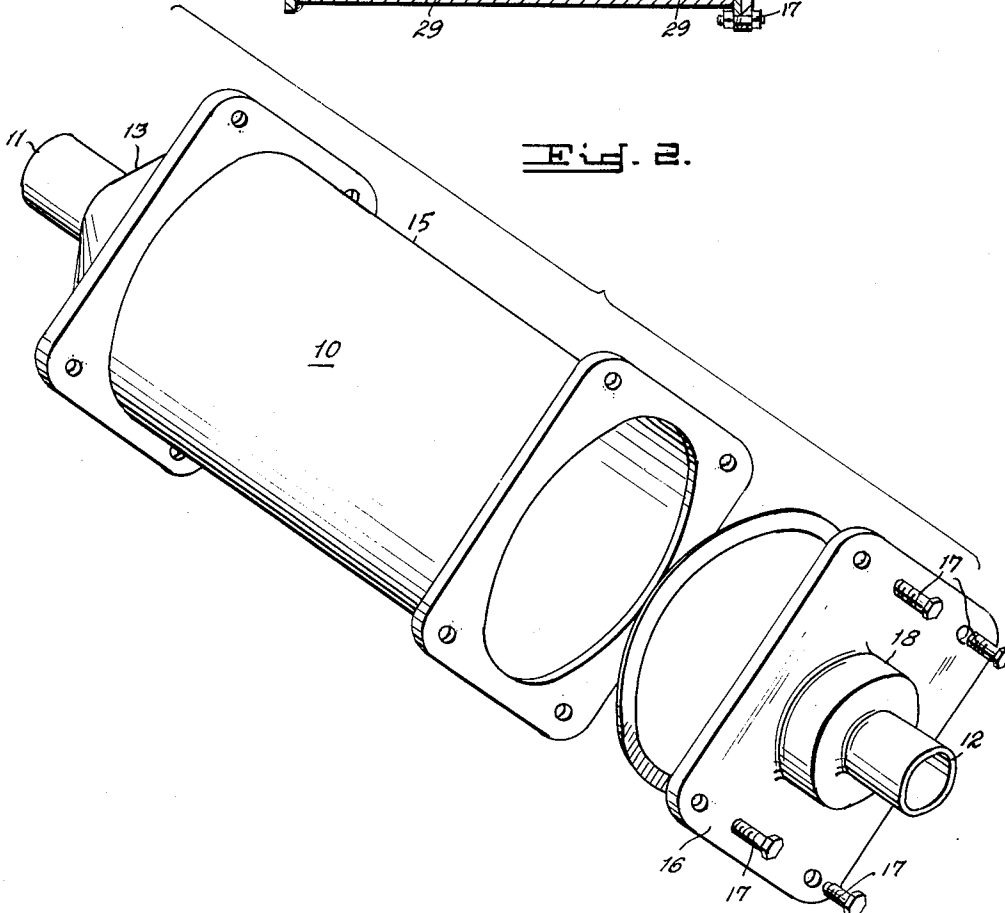

Fig. 2.



INVENTOR.

Hugh R. Jones
BY *Harry M. Saragovitz,*
Edward J. Kelly, Herbert Berl
& John W. Potlett Jr.

ATTORNEYS

Aug. 17, 1965

H. R. JONES

3,200,902

REPLACEABLE CARTRIDGE ACOUSTICAL MUFFLER

Filed April 7, 1964

2 Sheets-Sheet 2

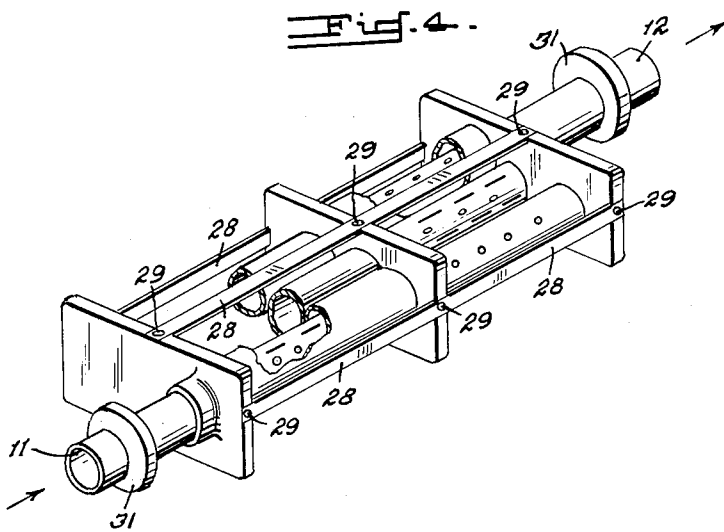
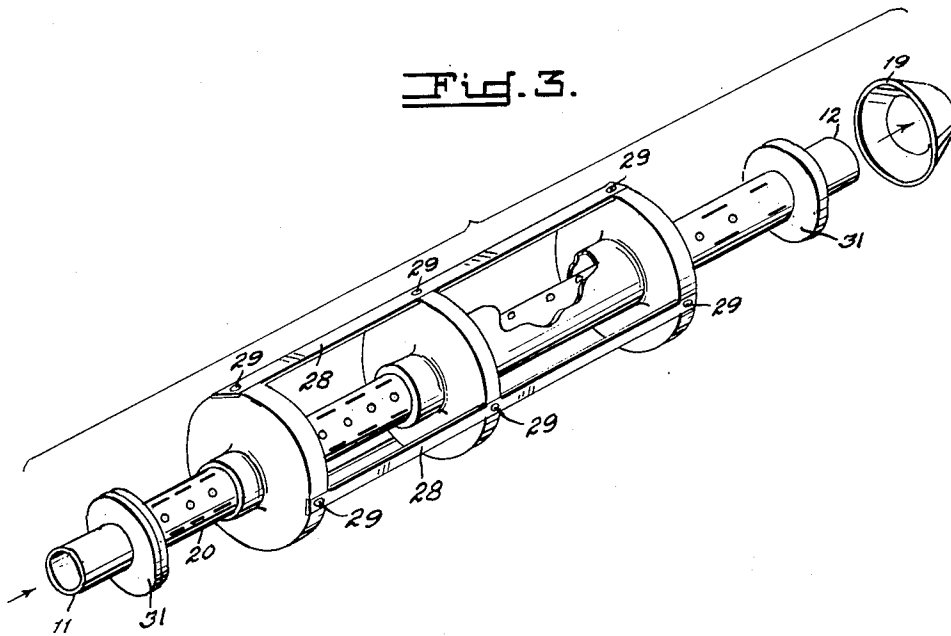

INVENTOR.
Hugh R. Jones
BY *Harry M. Saragovitz,*
Edward J. Kelly, Herbert Berl,
& John W. Potteit Jr.
ATTORNEYS

1

2

3,200,902

REPLACEABLE CARTRIDGE ACOUSTICAL MUFFLER

Hugh R. Jones, 8509 Thames St., Springfield, Va.

Filed Apr. 7, 1964, Ser. No. 358,126

4 Claims. (Cl. 181-61)

(Granted under Title 35, U.S. Code (1952), sec. 266)

The invention described herein may be manufactured and used by or for the Government of the United States of America for governmental purposes without the payment to me of any royalties thereon.

The present invention relates to replaceable cartridge acoustical mufflers and, more particularly, to a replaceable cartridge acoustical muffler for an internal combustion engine having exapansible rivets or bolts and expansible washers to secure the replaceable cartridge within a casing.

In prior replaceable cartridge acoustical mufflers, the cartridge would not properly fit into the casing therefor and such misfit caused the cartridge to vibrate noisily and would allow excessive exhaust gasses to bypass the muffler baffles. Further, the baffles would become bent when handled and shipped and by backfires through the muffler.

It is, therefore, an object of this invention to provide a muffler in which the replaceable cartridge is secured by expansible means, such as rivets, bolts or washers.

Another object of this invention is to provide a muffler which has a replaceable cartridge which is rattle free.

Still another object of this invention is to provide a muffler which has a replaceable cartridge that is rigidly constructed to prevent bending of the baffles before and after installation in the muffler casing.

Yet another object of this invention is to provide a replaceable cartridge acoustical muffler which is constructed so as to prevent excessive leakage of exhaust gasses around the baffles therein.

These and other objects are attained by the means described herein and disclosed in the accompanying drawings, in which:

FIGURE 1 is a sectional view of a casing with a pictorially represented cartridge mounted therein of a typical embodiment of this invention.

FIGURE 2 is a pictorial partially exploded showing of a typical outer casing of circular cross-sectional configuration of this invention.

FIGURE 3 is a pictorial view of a typical replaceable cartridge of circular cross-sectional configuration of this invention.

FIGURE 4 is a pictorial view of a second typical replaceable cartridge of rectangular configuration of this invention.

Briefly, this invention is directed toward an acoustical muffler having a replaceable cartridge. The outer casing is made such that the inner cartridge can be removed therefrom and another cartridge can be substituted therefor. The cartridge is secured within the casing by expansible elements, such as washers at the ends of the cartridge, a bevel washer at one of the cartridge ends and, when desired, by expansible rivets or bolts on the periphery of the baffle elements of the cartridge. The economy of a replaceable cartridge is thus afforded without the gas leaks and noisiness that prior devices inherently produced. Like numerals identify like parts throughout the several figures.

FIG. 1 shows a typical embodiment in which the outer shell 10 is shown in cylindrical configuration. The exhaust gasses enter the muffler through inlet 11 and escape through outlet 12. Inlet 11 diverges into a conical section 13 which ends in a circular planar section 14 the plane of which is perpendicular to the centerline of inlet 11. Cylindrical casing 15 is secured to the periphery of

circular planar section 14 either by welding or by rivets or by nuts and bolts or the like. The outlet end of 16 of outer shell 10 is secured to the cylindrical casing 15 by openable securing means 17 such as nuts and bolts or clamps or the like. Outlet end 16 is provided with an annular abutment 18 against which a bevel washer 19 rests. The configuration of the abutment 18 is determined by the shape of the cartridge and the positioning and tightening means utilized therewith. That is, the annular shape shown is only exemplary and rectangular, oval or any other shape required by the cartridge shape, may be utilized.

The cartridge 20, as shown in FIG. 1, is made up of a central tubing 21 which extends snugly into the inlet end 11 of the casing 10 at one end and snugly into the outlet end 12 at its other end. Central tubing 21 is provided with perforations 22 through which the exhaust gasses emerge into the sound deadening chambers 23, 24 and 25 which are bounded by inlet end 14, baffle 26 for chamber 23, baffles 26 and 27 for chamber 24 and baffle 27 and outlet end 16 for chamber 25, all three of which are closed by tubular wall 15. The size of the chambers is determined by the frequency of the sounds that are to be attenuated. Baffles 26 and 27 are permanently mounted on central tubing 21 and are reinforced by longitudinal strips 28. The baffles provide isolation of the gasses on each side thereof, that is, there is only a minimal transfer of gasses from one chamber to the other. The longitudinal strips 28 are secured to the baffles 26 and 27 by expansible rivets 29, or bolts or the like, so that the temperature of the exhaust gasses will lengthen the rivets toward the casing 15 and secure the cartridge within such casing. This permits the cartridge to be of such a dimension as to be readily installed into the casing and then, in use, to be snugly fitted thereto so as to avoid rattles and movement of the cartridge within the casing. The rattleless mounting of the cartridge is accomplished by further including expansible washers 31. These washers 31 can be used in pairs, one of which is connected to the central tubing 21 of the cartridge and serves as a support for the other washer which has a larger center hole with its outer edge abutting the conical section 13 of the outer casing. At the outlet end 16, the cartridge 20 is secured by an expansible washer connected to central tubing 21 with a cone-shaped disc spring, such as a Belleville spring, surrounding the central tubing 21 and compressed between the washer 31 and the annular abutment 18.

FIGURE 2 illustrates a typical outer casing 10 with a gasket supplied for sealing the outlet end 16 to the side tubing 15.

The outer configuration of the outer casing and the cartridge can be cylindrical, oval or rectangular or any other convenient cross-sectional shape such as illustrated in the drawing.

FIGURE 3 shows a straight through type cartridge having longitudinal strips 28 and expansible rivets 29 as in FIGURE 1. The bevel washer 19 is shown exploded from the central tubing.

The cartridge shown in FIG. 4 is a rectangular cross sectional configuration to fit within an outer casing of readily available rectangular tubing. This configuration lends itself satisfactorily to a reverse flow type of muffler. The outer shells for the cartridges of FIGS. 3 and 4 would be necessarily shaped to receive such cartridges with appropriate clearance for insertion thereof and for rattle free operation once installed.

In a typical embodiment of the invention, the ends 14 and 16 of the outer casing can be made of cast stainless steel such as ACI CC-50, the outer cylindrical shell of casing 10 can be made of ferritic stainless steel such as AISI 405, the central tubing 11, the partitions 26 and 27, longitudinal strips 28, and the expansible washers 31 can

be made of carbon steel such as AISI C1022, rivets 29 can be made of steel such as AISI C1022 for loose fit or aluminum AA6061 for tight fit, and the coned disc spring, the Belleville, can be made of stainless steel as AISI 405 or AISI 431.

So it is seen that I have provided a new and useful replaceable cartridge muffler having a series of tubes, baffles and partitions which induce the gas to flow in a straight-through, reverse-flow or diffused manner. The sound is thereby attenuated to a desirable level and frequency while allowing the gasses to be exhausted without under back pressure. At each end of the cartridge is permanently affixed an expansible washer 31 made of a material such that its coefficient of expansion is greater than that of the element itself and the outer shell material. These washers act to position the element within the outer shell along the longitudinal axis and, with increased temperatures, as occur with the passage of exhaust gasses therethrough, the thermal expansion of the washers exceeds that of the surrounding parts to insure a completely tight fit of the cartridge within the outer shell. To further insure a tight fit along the longitudinal axis, a spring or bevel washer 19 is provided. This spring or bevel washer insures a no-clearance fit under all conditions when the thermal expansion does not provide the tight fit.

To guide the replacement element in and out of the outer body during installation and removal of said element, rivets 29 are permanently affixed radially at each partition location, such as baffles 26 and 27. These rivets are made of similar material to the washers 31 and have a coefficient of expansion greater than that of the outer shell and of the cartridge. These rivets can be dimensioned to clear the outer shell by one sixty-fourth of an inch, for example, when the cartridge is cool for easy insertion. This linear expansion allows a dimensional increase from ambient temperature to exhaust gas temperature that enables the snug fit of the cartridge in the outer shell. In the operating temperatures of mufflers, the rivets will expand and secure the cartridge within the outer shell. It may be desirable that the cartridge be dimensioned so that the rivets do not touch the outer shell and the snugness of the washers could be sufficient to position the cartridge securely within the outer shell. This would require that the cartridge be about one-sixteenth of an inch smaller than the outer shell.

The longitudinal strips 28 act as restraining members against the tension and compression due to the pressures of the exhaust gasses on the faces of the partitions of the cartridge. Further, the strips align the baffles of the cartridge during handling and shipping.

The outer shell 10 is constructed of suitable material to withstand the pressure, heat and corrosion to which it is subjected. One or both ends are removable for replacement of the cartridge. The ends are properly gasketed and locked in place by screws, bolts, clamps, welding or the like for a gas tight seal.

The foregoing detailed description of illustrative embodiments is only given to provide a clear understanding

of the invention and the true scope of the invention is to be determined from the appended claims.

What is claimed is:

1. An acoustic muffler having a replaceable cartridge, an outer casing means for encasing said cartridge, said cartridge having a central tubing, a plurality of baffle means, a plurality of longitudinal strips, and a plurality of expansible securing means, said baffle means mounted on said central tubing, said longitudinal strips secured to said baffle means by said expansible securing means, said securing means being free from engagement with said outer casing means at ambient temperature and engaging said outer casing means at exhaust gas temperature.

2. An acoustic muffler having a replaceable cartridge, an outer casing means for encasing said cartridge, said cartridge having a tubing with an input and an output end, a plurality of baffle means, a plurality of longitudinal strips, a plurality of securing means, and a pair of expansible washers, said baffle means mounted on said central tubing, said longitudinal strips secured to said baffle means by said securing means, one of each of said pair of expansible washers secured in the vicinity of one of each of the ends of said tubing so as to tightly engage said outer casing at exhaust gas temperatures.

3. The acoustic muffler as in claim 2 including a bevel spring means mounted on said tubing between one of said expansible washers and said outer casing.

4. An acoustic muffler having a replaceable cartridge, an outer casing means for encasing said cartridge, said cartridge having a tubing with an input end and an output end, a plurality of baffle means, a plurality of longitudinal strips, a plurality of expansible securing means, and a pair of expansible washers, said baffle means separately mounted on said tubing, said longitudinal strips secured to said baffle means by said expansible securing means, said expansible securing means positioned so as to tightly engage said outer casing radially at exhaust temperature, expansible washers secured in the vicinity of one of each of the ends of said tubing so as to tightly engage said outer casing longitudinally at exhaust gas temperature.

References Cited by the Examiner

UNITED STATES PATENTS

1,061,272	5/13	De Witt	181—62 X
2,179,054	11/39	Robbins	181—35
2,187,431	1/40	Powell	181—35
2,244,393	6/41	Haas	181—61
2,259,516	10/41	Deremer	181—61
2,428,040	9/47	Sauerbier	181—62 X
2,705,541	4/55	Finch	
2,778,192	1/57	Kroon	60—39.32
2,795,103	6/57	Jenison	
2,853,367	9/58	Karol et al.	60—29 X

FOREIGN PATENTS

364,222 1/32 Great Britain.

LEO SMILOW, *Primary Examiner*.